

ANNOTATED AGENDA

for
February 28, 2012

CITY COUNCIL MEETING
Including the Antioch City Council
acting as Successor Agency/Housing Successor
to the Antioch Development Agency

Order of Council vote: AYES: Council Members Harper, Rocha, Agopian and Mayor Davis
ABSENT: Council Member Kalinowski

Notice of Availability Reports

This agenda is a summary of the actions proposed to be taken by the City Council. For almost every agenda item, materials have been prepared by the City staff for the Council's consideration. These materials include staff reports which explain in detail the item before the Council and the reason for the recommendation. The materials may also include resolutions or ordinances which are proposed to be adopted. Other materials, such as maps and diagrams, may also be included. All of these materials are available at the City Clerk's Office, located on the 1st floor of City Hall, 3rd and H Streets, Antioch, CA 94509, during normal business hours for inspection and (for a fee) copying. Copies are also made available at the Antioch Public Library for inspection. Questions on these materials may be directed to the staff member who prepared them, or to the City Clerk's Office, who will refer you to the appropriate person.

Notice of Opportunity to Address Council

The public has the opportunity to address the Council on each agenda item. To address the Council, fill out a yellow Speaker Request form, available on each side of the entrance doors, and place in the Speaker Card Tray. See the Speakers' Rules on the inside cover of this Agenda. Comments regarding matters not on this Agenda may be addressed during the "Public Comments" section.

6:00 P.M. ROLL CALL for Closed Sessions – *Mayor Davis and Council Members Harper (6:27 p.m.), Agopian and Rocha (Council Member Kalinowski Absent)*

PUBLIC COMMENTS for Closed Sessions – *None*

CLOSED SESSIONS: 1) **CONFERENCE WITH LABOR NEGOTIATOR** – City designated representatives: Deborah McHenry and Glenn Berkheimer; Employee organizations: Public Employees' Union Local No. 1; Antioch Police Officers' Association. This Closed Session is authorized by California Government Code §54957.6. **No Action to Report Out**

7:00 P.M. ROLL CALL for Council Members/City Council Members acting as Successor Agency/ Housing Successor to the Antioch Development Agency – *Council Member Kalinowski Absent*

PLEDGE OF ALLEGIANCE

ANNOUNCEMENTS OF CIVIC AND COMMUNITY EVENTS

PUBLIC COMMENTS—*Only unagendized issues will be discussed during this time*

CITY COUNCIL SUBCOMMITTEE REPORTS

MAYOR'S COMMENTS

1. COUNCIL CONSENT CALENDAR

A. APPROVAL OF COUNCIL MINUTES FOR FEBRUARY 14, 2012

Recommended Action: Motion to approve the minutes

Approved, 4/0

MINUTES

B. APPROVAL OF COUNCIL WARRANTS

Recommended Action: Motion to approve the warrants

Approved, 4/0

STAFF REPORT

C. APPROVAL OF TREASURER'S REPORT FOR JANUARY 2012

Recommended Action: Motion to approve the report

Approved, 4/0

STAFF REPORT

COUNCIL CONSENT CALENDAR — Continued

D. REJECTION OF CLAIMS

1. Thomas Moore 11/12-2049 (water bill refund)
2. Donna Humphreys 12/13-2053 (property damage)

Rejected, 4/0

Recommended Action: Motion to reject the listed claims

STAFF REPORT

E. ADOPTION OF THE 2010 FIRE CODE AND ADOPTING BY REFERENCE ORDINANCE NO. 2010-15 OF THE CONTRA COSTA COUNTY FIRE PROTECTION DISTRICT WITH LOCAL FINDINGS AND AMENDMENTS

- Recommendation:
- 1) Motion to read the ordinance by title only; and
 - 2) Motion to introduce an ordinance amending Chapter 15 of Title 8 of the Antioch Municipal Code, adopting by reference Ordinance No. 2010-15 of the Contra Costa County Fire Protection District and the 2010 California Fire Code with amendments. ***To 03/13/12 for adoption, 4/0***

STAFF REPORT

F. FOUR PERSON LANDSCAPE MAINTENANCE CREW BID AWARD

Approved, 4/0

Recommended Action: Motion to award the Four Person Landscape Maintenance Crew (Bid No. 988-0202-12F) to the overall low bidder, Pacific Coast Landscape Management Inc., Brentwood, CA for \$599.00 per day (based on an 8 hour day) not to exceed \$150,000 per year for the term of five years

STAFF REPORT

G. CHICHIBU PARK RECYCLED WATER SPECIFIC RETROFIT BID AWARD

Recommended Action: Motion to award the contract (Bid No. 988-0202-12G) to the overall low bidder, Robert A. Bothman, Inc., San Jose, CA, in the amount of \$126,975 with funding provided by the Proposition 50, Integrated Regional Water Management Grant Program

Approved with revised Recommendation, 4/0

Revised Recommendation: Motion to recommend that City Council authorize the award of the contract (Bid No. 988-0202-12G) to the low bidder, Robert A. Bothman, Inc., San Jose, CA, in the amount of \$126,975 if contract terms acceptable to the City Manager and City Attorney can be reached; otherwise to authorize the award of contract to the second low bidder, Pacheco Brothers, in the amount of \$153,250

STAFF REPORT

H. CITY COUNCIL TO AUTHORIZE "KEEP ANTIOCH BEAUTIFUL" DAY AS CITY SPONSORED EVENT

Approved, 4/0

Recommended Action: Motion to recognize April 21, 2012 as "Keep Antioch Beautiful" day and permanently add it to the City Event Policy as a City-Sponsored Event

END OF CONSENT CALENDAR

STAFF REPORT

COUNCIL REGULAR AGENDA

2. LONE TREE GOLF COURSE CITY COUNCIL SUB-COMMITTEE REPORT

Approved, 4/0

- Recommendation:
- 1) The Antioch Golf Corporation payment of the 2001/02 ABAG loan shall be the top debt service priority. Review annually
 - 2) Defer all other loan payments until after the ABAG loan payments are current. Review annually
 - 3) Seek an alternate funding source for the reclaimed water costs for the course (Approx. \$90,000 per year). Review annually
 - 4) A review the golf course operational budget to be done annually by the Ad-hoc Subcommittee, prior to approval by their Board of Directors.
 - 5) Review "Summary" section of this report and provide direction.

STAFF REPORT

3. BUDGET DISCUSSION RELATED TO POLICE DEPARTMENT STAFFING

Direction provided to hire 3 Officers and up to 5 per-diem Officers, 4/0

Recommended Action: Motion to provide direction to staff

STAFF REPORT

4. COMPUTER GAMING AND INTERNET ACCESS BUSINESSES

Recommendation: It is recommended that the City Council approve a:

- 1) Motion to read the Interim Zoning Ordinance, Urgency Ordinance, and Regular Ordinance by title only; **Approved, 4/0**
- 2) Motion to adopt the attached Interim Urgency Zoning Ordinance prohibiting the issuance of permits, approvals or licenses for construction, establishment or operation of any computer gaming and internet access business within the City of Antioch **Ord.2052-C-S, 4/0**
- 3) Motion to adopt an Urgency Ordinance amending Title 5 of the Antioch Municipal Code by adding Chapter 11 pertaining to the licensing procedures and regulations for Computer Gaming and Internet Access Businesses and making findings declaring the urgency thereof **Ord. 2053-C-S, 4/0**
- 4) Motion to introduce a Regular Ordinance amending Title 5 of the Antioch Municipal Code by adding Chapter 11 pertaining to the licensing procedures and regulations for Computer Gaming and Internet Access Businesses **To 03/13/12 for adoption, 4/0**
- 5) Motion to adopt a resolution to initiate an amendment to the Zoning Ordinance to address computer gaming and internet access businesses **Reso 2012/12, 4/0**

STAFF REPORT

COUNCIL REGULAR AGENDA – Continued

5. BALLOT MEASURE TO MAKE THE OFFICES OF CITY CLERK AND CITY TREASURER APPOINTED

Reso 2012/13, 4/0

Action Item: Resolution calling a Special Municipal Election on June 5, 2012 for the submission to the voters of a local ballot measure to make the Offices of City Clerk and City Treasurer appointed and requesting that the Board of Supervisors of Contra Costa County to consolidate a municipal election on a local measure with other elections to be held on the June 5, 2012 Regular Election

STAFF REPORT

6. BALLOT MEASURE TO ELIMINATE THE DIRECTLY ELECTED MAYOR

Reso 2012/14, 4/0

Action Item: Resolution calling a Special Municipal Election on June 5, 2012 for the submission to the voters of a local ballot measure to eliminate the position of a directly elected mayor and requesting that the Board of Supervisors of Contra Costa County to consolidate a municipal election on a local measure with other elections to be held on the June 5, 2012 Regular Election

STAFF REPORT

7. SHOPPING CARTS RECOVERY

Received and direction given to re-draft letter, 4/0

Recommended Action: Motion to receive and file report from the Commercial Code Enforcement/Shop Antioch subcommittee and provide direction on letter to merchants

STAFF REPORT

8. **CITY OF ANTIOCH AS SUCCESSOR AGENCY TO THE ANTIOCH DEVELOPMENT AGENCY**

- A. APPROVAL OF SUCCESSOR AGENCY WARRANTS

Approved, 4/0

Recommended Action: Motion to approve the warrants

STAFF REPORT

9. **CITY OF ANTIOCH AS HOUSING SUCCESSOR TO THE ANTIOCH DEVELOPMENT AGENCY**

- A. APPROVAL OF HOUSING SUCCESSOR WARRANTS

Approved, 4/0

Recommended Action: Motion to approve the warrants

STAFF REPORT

PUBLIC COMMENT

STAFF COMMUNICATIONS

COUNCIL COMMUNICATIONS

ADJOURNMENT – 9:46 p.m.

ANTIOCH CITY COUNCIL

Regular Meeting
7:00 P.M.

February 14, 2012
Council Chambers

6:30 P.M. - CLOSED SESSION

1. CONFERENCE WITH LABOR NEGOTIATOR – City designated representatives: Deborah McHenry and Glenn Berkheimer; Employee organizations: Public Employees' Union Local No. 1; Antioch Police Officers' Association. This Closed Session is authorized by California Government Code §54957.6.

City Attorney Nerland reported the City Council had been in Closed Session and gave the following report: #1 Conference with Labor Negotiator - no reportable action/direction was given to the Labor Negotiator. She reported at the last Council meeting on January 24, 2012, a decision was made by the City Council not to appeal the Superior Court's decision in the Walmart litigation on a 3-2 vote with Mayor Davis and Council Member Agopian voting against the motion to not appeal the decision, this action is reflected in the Minutes and Annotated Agenda.

Mayor Davis called the meeting to order at 7:14 P.M., and City Clerk Skaggs called the roll.

Present: Council Members Kalinowski, Harper, Rocha, Agopian and Mayor Davis

PLEDGE OF ALLEGIANCE

Mayor Pro Tem Harper led the Council and audience in the Pledge of Allegiance.

Mayor Davis called an emergency town hall meeting on February 21, 2012, at 7:00 P.M. to discuss ways to stop the violence in Antioch. He noted items to be discussed would include; crime statistics, options for funding additional Sworn Police Officers, the Neighborhood Watch Program, and the early release program.

(The City Council later postponed the meeting to give staff time to prepare, given city furloughs and Monday's holiday).

ANNOUNCEMENTS OF CIVIC AND COMMUNITY EVENTS - None

PUBLIC COMMENTS

Douglas Tokes, Antioch resident, spoke in support of a flat tax dedicated to emergency services and suggested a utility tax as a more feasible way to provide funding. He also suggested lighting the Antioch Bridge.

Martin Fernandez, Antioch resident, spoke to the budget challenges facing the city and suggested the City Council begin addressing this year's budget as soon as possible.

A

02/28/12

Fred Hoskins, Antioch resident, requested the renovation of the Hard House property be placed on the next City Council agenda. He spoke to a previous application for an Internet Café in downtown Antioch.

Julie Young, representing residents in her Antioch neighborhood, provided photos and expressed concern regarding the construction of Nelson Ranch Park. She noted they were never informed of the project and its current design; would negatively impact their quality. She requested the city work with the residents for a solution to these concerns.

Councilmember Rocha suggested looking at Mira Vista Park to see what they had done to mitigate similar concerns.

Councilmember Kalinowski requested this issue be placed on a future agenda to be discussed.

Ms. Young stated she wants to make sure what was approved by the city is what was currently being built and requested the city provide the 2004 map and plans for the park.

Erin Johnson, Policy Coordinator for the East County Alcohol Policy Coalition, introduced himself and gave a brief history and update on the activities of the coalition. Contact information was provided.

Martha Parsons, Antioch resident, provided a list of city's within Contra Costa County with a rotating Mayor position, and suggested the City Council discuss the feasibility of rotating the Mayor position in Antioch.

Bill Moore, Antioch resident, speaking with regards to the Nelson Ranch Park, voiced his support for his neighbors. He thanked the city for addressing his concerns and removing trees to preserve his view. He questioned why they were not notified by the city regarding the impacts of the park, prior to construction.

COUNCIL SUBCOMMITTEE REPORTS

Councilmember Agopian reported on his attendance at the Blight/Shop Antioch subcommittee meeting. He requested this item be agendaized for discussion at a future City Council meeting.

Mayor Davis reported on his attendance at the Blight/Shop Antioch subcommittee meeting.

Councilmember Rocha reported on her attendance at the joint Antioch School District/City subcommittee meeting and announced the next meeting would be March 26, 2012, at Antioch High School. She also reported on her attendance at Supervisor Federal Glover's Breakfast Club.

Councilmember Harper reported on his attendance at the Antioch School Board/City subcommittee meeting and the Foreclosure Prevention Workshop.

Councilmember Kalinowski reported on his attendance at the dedication of the Highway 4 Bypass to CALTRANS and the Highway 4/eBART construction. He announced groundbreaking for the bypass improvements should occur in June 2012.

MAYOR'S COMMENTS

Mayor Davis thanked all Councilmembers for the service they gave the community on the dais and through subcommittee appointments. He reported on his attendance at the California League of Cities Public Safety Policy Committee held in Sacramento on January 20, 2012.

PRESENTATION ON POLICE STATS FOR YEAR 2011

Chief of Police Allan Cantando presented the Antioch Police Department Information Report including crime statistics and the bureaus of support and field services.

In response to the City Council, Chief Cantando stated he would provide the City Council with the following information:

- Recidivism rate of those students who had successfully completed the REACH program
- The number of documented gang members who purport to live in Antioch
- The times calls for service were received and how long on average they were held until dispatched
- The average cost approximation for a homicide investigation
- His vision for the Antioch Police Department

In response to Councilmember Kalinowski, Chief Cantando noted the department was taking seriously and addressing missed court dates.

Councilmember Kalinowski requested Mayor Davis bring a discussion to the Mayor's conference regarding how insufficient funding and staffing in the Deputy District Attorney office, was causing the lack of filing cases.

Chief Cantando announced the following events: Coffee with the Cops, 9:00 A.M. – 12:00 P.M. on March 10, 2012, and Volunteers in Police Services Orientation, 6:00 P.M. on March 13, 2012, both events would take place in the Antioch Police Department Community Room.

Councilmember Harper thanked Chief Cantando for the report and transparency in which the Antioch Police Department operated and encouraged the Antioch Police Department to continue focusing on crime suppression in the Sycamore corridor.

Councilmember Rocha spoke in support of foot patrol in high crime areas, once the Antioch Police force was more effectively staffed. Additionally, she suggested the City Council discuss taxing individuals who own more than two income properties in Antioch.

Councilmember Agopian expressed his appreciation to the Antioch Police Department. He stated he felt it was time for the citizens of Antioch to work proactively and approve a parcel tax to provide targeted resources to address criminal activity in Antioch.

Mayor-Davis, speaking on behalf of the City Council, stated they would do whatever they could to help the Antioch Police Department and spoke to the value of the Neighborhood Watch program.

City Manager Jakel stated if the City Council deem increasing the staffing levels of the Antioch Police Department a priority, they could use the city's reserves, to fund additional positions.

Councilmember Agopian suggested holding monthly Coffee with the Cops events throughout the community to engage the public on the issues.

Mayor Davis stated he would work with staff to schedule a date for a town hall meeting.

City Manager Jakel stated he would bring an item to the City Council on the next agenda, regarding the funding of additional positions for the Antioch Police Department.

Councilmember Kalinowski requested Chief Cantando provide the City Council with his vision for the Antioch Police Department for the next two years prior to considering the usage of the city's reserve funds to staff additional positions.

Mayor Davis thanked Chief Cantando for the presentation this evening.

COUNCIL CONSENT CALENDAR

- A. APPROVAL OF COUNCIL MINUTES FOR JANUARY 24, 2012**
- B. APPROVAL OF COUNCIL WARRANTS**
- C. REJECTION OF CLAIMS**
 - 1. Isaiah Akinsanya 11/12-2029A (personal injury)**
 - 2. Randall Thomas 11/12-2029B (personal injury)**
- D. REQUEST TO AUTHORIZE USE OF CITY LOGO FOR CESAR CHAVEZ DAY**
- E. RESOLUTION NO. 2012/09 OF THE CITY COUNCIL OF THE CITY OF ANTIOCH SUPPORTING THE CHOOSE CIVILITY INITIATIVE SPONSORED BY THE CONTRA COSTA COUNTY OFFICE OF EDUCATION**
- F. PURCHASE LOADER FOR WATER TREATMENT PLANT IN FISCAL YEAR 2011/2012**
- G. AWARD OF COPIER LEASE CONTRACT**

- H. **RESOLUTION NO. 2012/10 STREET LIGHTING AND LANDSCAPING MAINTENANCE DISTRICT ENGINEER'S REPORT FOR FY 2012/2013**
- I. **APPROVAL TO INCREASE FUNDS FOR THE HILLCREST AVENUE WIDENING, PHASE II PROJECT (P.W. 276-10)**
- J. **AUTHORIZATION TO ENTER INTO A CONTRACT WITH RANEY PLANNING & MANAGEMENT, INC. FOR ENVIRONMENTAL DOCUMENT PREPARATION FOR THE WALMART EXPANSION PROJECT**
- K. **RESOLUTION NO. 2012/11 IN SUPPORT OF THE CITY FILING A GRANT APPLICATION WITH THE STATE OF CALIFORNIA UNDER THE STATE'S "SUSTAINABLE COMMUNITIES PLANNING GRANT AND INCENTIVE PROGRAM" TO RECEIVE FUNDING TO PREPARE A SPECIFIC PLAN FOR THE CITY'S DOWNTOWN AREA**

On motion by Councilmember Rocha, seconded by Councilmember Agopian, the City Council unanimously approved the Council Consent Calendar with the exception of items J and K, which were removed for further discussion.

Item J – In response to Fred Hoskins, Antioch resident, City Attorney Nerland reported the property owner submitted the application, and by law, the city was required to process that application. She noted the applicant would be paying the costs of the Environmental Consultant.

On motion by Councilmember Kalinowski, seconded by Councilmember Agopian, the City Council unanimously approved item J.

Item K – Councilmember Rocha clarified the specific plan was for the city's downtown area.

Fred Hoskins, Antioch resident, stated he felt the plans and timeline for downtown needed to be outlined prior to submittal of the grant application.

On motion by Councilmember Rocha, seconded by Councilmember Kalinowski, the City Council unanimously approved item K.

Mayor Davis declared a recess at 9:17 P.M. The meeting reconvened at 9:32 P.M. with all Councilmembers present.

COUNCIL REGULAR AGENDA

2. ELECTED CITY CLERK AND ELECTED CITY TREASURER

City Attorney Nerland presented the staff report dated February 7, 2012, recommending the City Council provide direction to staff regarding 1) A ballot measure for the June 5, 2012, election to appoint the City Treasurer, 2) A ballot measure for the June 5, 2012, election to appoint the City

Clerk. Provide other direction to staff regarding the elected positions of City Clerk and/or City Treasurer.

On motion by Councilmember Agopian, seconded by Councilmember Harper, the City Council unanimously directed staff to prepare a resolution and other documents needed to place one ballot measure on the June 2012 ballot to make both the City Clerk and City Treasurer appointive positions.

3. REQUEST TO AUTHORIZE A WATER BILL INSERT FOR FOURTH OF JULY EVENT

City Manager Jakel presented the staff report dated February 7, 2012, recommending the City Council provide direction.

Joy Motts and members of the 4th of July Committee voiced their appreciation to the City Council for agendizing this issue and gave a brief update on the fundraising efforts and activities for the event.

Mayor Davis stated he it was encouraging to hear the event returning to Antioch.

Councilmember Rocha encouraged the committee to consider providing healthy food options for children.

On motion by Councilmember Harper, seconded by Councilmember Rocha, the City Council unanimously approved allowing the Fourth of July group to place fundraising and publicity inserts in the City's water bills with the organization paying costs.

PUBLIC COMMENTS - None

STAFF COMMUNICATIONS

City Manager Jakel announced a joint meeting of the City and Antioch Unified School District would be held at 5:30 P.M. on March 26, 2012, at Antioch High School and the next regularly scheduled City Council meeting was February 28, 2012.

COUNCIL COMMUNICATIONS

Mayor Davis requested staff agendize a discussion on making the Mayor's position, a rotating position.

Councilmember Rocha stated she felt the City Council needed to discuss taxing individuals who own more than two income properties in Antioch.

ADJOURNMENT

With no further business, Mayor Davis adjourned the meeting at 9:50 P.M. to the next regular Council meeting on February 28, 2012.

Respectfully submitted:

Kitty Eiden

KITTY EIDEN, Minutes Clerk

CITY OF ANTIOCH
 CLAIMS BY FUND REPORT
 FOR THE PERIOD OF
 FEBRUARY 9-22, 2012
 FUND/CHECK#

100 General Fund

Non Departmental

131962 BREWER FRASER HOLLAND AND LOTITO	DEPOSIT REFUND	3,500.00
131967 CONTRA COSTA ARC	DEPOSIT REFUND	2,500.00
131972 CONTRA COSTA WATER DISTRICT	CCWD FACILITY RESERVE FEE	102,243.00
131973 CONTRA COSTA WATER DISTRICT	TREATED WATER CAPACITY FEE	23,548.98
131978 ECC REG FEE AND FIN AUTH	ECCRFFA-RTDIM	148,342.00
131982 FIRST 5 CONTRA COSTA	DEPOSIT REFUND	3,500.00
132004 RECIPIENT	MLK 2010 AWARD WINNER	500.00
132014 QUALITY PROJECT MANAGEMENT	DEPOSIT REFUND	4,000.00
132028 WOODMAN, GLENN AND DIANE	DEPOSIT REFUND	2,000.00
916726 ZUMWALT ENGINEERING GROUP INC	ENGINEERING SERVICES	1,050.00

City Council

132012 PERS	COUNCIL PAYMENT	259.78
-------------	-----------------	--------

City Attorney

132075 LEXISNEXIS MATTHEW BENDER	ONLINE LEGAL RESEARCH	75.00
----------------------------------	-----------------------	-------

City Manager

132007 OFFICE MAX INC	OFFICE SUPPLIES	94.41
132072 KARSTE CONSULTING INC	CONSULTING SERVICES	1,560.00

City Clerk

132033 AMERICAN LEGAL PUBLISHING	INTERNET SUPPLEMENT	1,699.66
132059 EIDEN, KITTY J	MINUTES CLERK	196.00
200349 DFM ASSOCIATES	LITERATURE	67.39

City Treasurer

131983 GARDA CL WEST INC	ARMORED CAR PICK UP	202.30
132011 PFM ASSET MGMT LLC	PROFESSIONAL SERVICES	5,724.55
916718 CONLEY, DONNA	VEHICLE ALLOWANCE	350.00

Human Resources

131954 EMPLOYEE	EDUCATION INCENTIVE	303.78
132006 OCCUPATIONAL HEALTH CENTERS	PREEMPLOYMENT PHYSICAL	171.15
132009 PARS	ADMIN FEE NOV11	1,036.91

Economic Development

131948 ANTIOCH AUTO CENTER	TAX REBATE	71,376.00
916717 BERNICK, MICHAEL	PROFESSIONAL SERVICES	3,450.00

Finance Administration

132007 OFFICE MAX INC	OFFICE SUPPLIES	41.87
132086 OFFICE MAX INC	OFFICE SUPPLIES	11.75

Finance Accounting

131945 AMERICAN PAYROLL ASSOC	MEMBERSHIP RENEWAL	219.00
131953 AT AND T MCI	BITECH PHONE LINE	476.49
131980 FEDEX	SHIPPING	17.67
132018 SAUNDERS, LISA D	MILEAGE REIMBURSEMENT	43.70
132086 OFFICE MAX INC	W2 FORMS	56.02

Finance Operations

132007 OFFICE MAX INC	WATER BILL FORMS	1,209.61
132021 TYLER TECHNOLOGIES	MONTHLY INSITE FEES	680.00

Prepared by: Georgina Meek
 Finance Accounting

2/23/2012

CITY OF ANTIOCH
 CLAIMS BY FUND REPORT
 FOR THE PERIOD OF
 FEBRUARY 9-22, 2012
 FUND/CHECK#

132022 UNITED PARCEL SERVICE	WEEKLY PRINTER SERVICE FEE	12.00
132086 OFFICE MAX INC	OFFICE SUPPLIES	72.42
Non Departmental		
131974 DAVID WELLHOUSE AND ASSOC INC	STATE MANDATE FILING	3,000.00
131991 INSTORE ENTERPRISERS LLC	BUS LIC PAYMENT REFUND	312.50
132003 MUNISERVICES LLC	SUTA SERVICE	1,087.00
132013 PERS	ADMIN FEE	1,487.01
132081 MUNICIPAL POOLING AUTHORITY	LIABILITY INSURANCE	20,599.82
201396 UNIVERSAL SECURITY AND FIRE INC	BUS LIC PENALTY REFUND	27.50
201397 HABIBATIQUE ETHNIC	BUS LIC PENALTY REFUND	2.50
201398 CRS COMMERCIAL	BUS LIC STICKER FEE REFUND	5.00
201399 RTS MOBILE WELDING SERVICE	BUS LIC STICKER FEE REFUND	5.00
916710 RETIREE	MEDICAL AFTER RETIREMENT	49.74
Public Works Maintenance Administration		
132005 NEXTEL SPRINT	CELL PHONE	122.16
Public Works General Maintenance Services		
132005 NEXTEL SPRINT	CELL PHONE	81.23
Public Works Street Maintenance		
132005 NEXTEL SPRINT	CELL PHONE	42.18
132050 CROP PRODUCTION SERVICES INC	CHEMICALS	4,366.26
Public Works-Signal/Street Lights		
131953 AT AND T MCI	PHONE	564.29
132026 WESCO RECEIVABLES CORP	SUPPLIES	2,834.42
132069 ICR ELECTRICAL CONTRACTORS	ELECTRICAL SERVICES	1,927.69
132116 WESCO RECEIVABLES CORP	SUPPLIES	2,968.41
Public Works-Striping/Signing		
131998 LOWES COMPANIES INC	SUPPLIES	25.59
132029 ZAP MANUFACTURING INC	SIGNS	264.32
Public Works-Facilities Maintenance		
131953 AT AND T MCI	PHONE	45.53
131998 LOWES COMPANIES INC	SUPPLIES	9.80
132007 OFFICE MAX INC	OFFICE SUPPLIES	7.10
132026 WESCO RECEIVABLES CORP	SUPPLIES	213.04
132077 M AND L OVERHEAD DOORS	GATE REPAIR	375.00
132084 OAKLEYS PEST CONTROL	PEST CONTROL SERVICE	100.00
132116 WESCO RECEIVABLES CORP	SUPPLIES	213.04
Public Works-Parks Maint		
131953 AT AND T MCI	PHONE	78.20
131975 DELTA LOCK KEY AND SAFE	REPAIR SERVICE	488.46
132008 PACIFIC GAS AND ELECTRIC CO	ELECTRIC	171.59
132026 WESCO RECEIVABLES CORP	SUPPLIES	1,822.61
132069 ICR ELECTRICAL CONTRACTORS	ELECTRICAL SERVICES	126.07
132090 PACHECO BROTHERS GARDENING INC	LANDSCAPE SERVICES	39,185.29
132105 STEWARTS TREE SERVICE	TREE SERVICE	2,435.00
132116 WESCO RECEIVABLES CORP	SUPPLIES	1,822.61
916721 JOHN DEERE LANDSCAPES ANTIOCH	IRRIGATION CONTROLLER PARTS	1,416.53

Prepared by: Georgina Meek
 Finance Accounting

CITY OF ANTIOCH
 CLAIMS BY FUND REPORT
 FOR THE PERIOD OF
 FEBRUARY 9-22, 2012
 FUND/CHECK#

Public Works-Median/General Land

131953 AT AND T MCI	PHONE	146.87
131979 EDD	UNEMPLOYMENT CLAIMS	78.00
132085 ODYSSEY LANDSCAPE CO INC	LANDSCAPE SERVICES	192.00

Public Works-Work Alternative

132005 NEXTEL SPRINT	CELL PHONE	98.38
----------------------	------------	-------

Police Administration

131955 BANK OF AMERICA	FUEL	446.47
131956 BANK OF AMERICA	TRAINING-SMITH	1,350.00
131966 CONCORD UNIFORMS LLC	UNIFORMS	7,405.83
131979 EDD	UNEMPLOYMENT CLAIMS	1,303.00
131980 FEDEX	SHIPPING	23.17
132007 OFFICE MAX INC	OFFICE SUPPLIES	988.34
132031 ACME SECURITY SYSTEMS	SECURITY	250.00
132037 ARROWHEAD 24 HOUR TOWING INC	TOWING SERVICES	222.50
132098 SAN DIEGO POLICE EQUIPMENT CO	SUPPLIES	6,346.48
132111 US BANK	COPIER LEASE	356.60
916707 ARATA PRINTING	PRINTING SERVICE	297.69
916711 MOBILE MINI LLC	STORAGE CONTAINER RENTAL	106.76
916720 HUNTINGTON COURT REPORTERS INC	TRANSCRIPTION SERVICES	1,079.00
916722 MOBILE MINI LLC	STORAGE CONTAINER RENTAL	208.52

Police Prisoner Custody

131979 EDD	UNEMPLOYMENT CLAIMS	816.00
132013 PERS	PAYROLL DEDUCTIONS	1,041.00
132074 LAMOTHE CLEANERS	DRY CLEANING	80.00

Police Community Policing

131966 CONCORD UNIFORMS LLC	UNIFORMS	76.07
131979 EDD	UNEMPLOYMENT CLAIMS	1,800.00
132068 HUNT AND SONS INC	FUEL	64.00
132079 MOORE K9 SERVICES	K-9 TRAINING	500.00
201446 CITY OF ANTIOCH	EXPENSE REIMBURSEMENT	58.17

Police Traffic Division

132013 PERS	PAYROLL DEDUCTIONS	3.75
-------------	--------------------	------

Police Investigations

132002 METRO PCS	PHONE RECORDS	50.00
132020 THOMSON WEST	ONLINE DATABASE	296.10
201446 CITY OF ANTIOCH	EXPENSE REIMBURSEMENT	40.07

Police Communications

131953 AT AND T MCI	PHONE	1,170.22
132007 OFFICE MAX INC	OFFICE SUPPLIES	277.67
916709 CRYSTAL CLEAR LOGOS INC	UNIFORMS	51.94

Office Of Emergency Management

131953 AT AND T MCI	PHONE	294.23
---------------------	-------	--------

Police Community Volunteers

131956 BANK OF AMERICA	SUPPLIES	183.85
------------------------	----------	--------

CITY OF ANTIOCH
 CLAIMS BY FUND REPORT
 FOR THE PERIOD OF
 FEBRUARY 9-22, 2012
 FUND/CHECK#

Police Facilities Maintenance

131953 AT AND T MCI	PHONE	268.52
132023 UNITED SITE SERVICES OF CALIFORNIA	PORTABLE RESTROOM RENTAL	413.88
132034 AMERICAN PLUMBING INC	PLUMBING SERVICES	253.63
132107 THE GARLAND COMPANY	SUPPLIES	428.19

Community Development Land Planning Services

131979 EDD	UNEMPLOYMENT CLAIMS	4,024.00
------------	---------------------	----------

Community Development Neighborhood Improvement

132005 NEXTEL SPRINT	CELL PHONE	107.78
----------------------	------------	--------

PW Engineer Land Development

131953 AT AND T MCI	PHONE	29.92
132005 NEXTEL SPRINT	CELL PHONE	202.74
132013 PERS	PAYROLL DEDUCTIONS	124.15

Community Development Building Inspection

132005 NEXTEL SPRINT	CELL PHONE	112.40
132007 OFFICE MAX INC	BUSINESS CARDS-MUNN/VIGIL	66.78

Capital Imp. Administration

132005 NEXTEL SPRINT	CELL PHONE	239.69
----------------------	------------	--------

Community Development Engineering Services

132005 NEXTEL SPRINT	CELL PHONE	64.98
----------------------	------------	-------

212 CDBG Fund

CDBG

131987 HOUSE, TERI	CONSULTANT SERVICES	5,225.00
131993 KENNEDY, JANET	CONSULTANT SERVICES	330.00
132040 BAY AREA NEWS GROUP	LEGAL AD	313.68
132086 OFFICE MAX INC	OFFICE SUPPLIES	64.37

CDBG NSP

131969 CONTRA COSTA COUNTY	NSP REHAB LOAN	73,159.50
131970 CONTRA COSTA COUNTY	NSP REHAB LOAN	106,817.00
131993 KENNEDY, JANET	CONSULTANT SERVICES	1,560.00
132017 SATELLITE HOUSING INC	LOAN PAYMENT	22,730.32
132060 FIRST AMERICAN TITLE CO	MADRONE LOAN	6,280.00

213 Gas Tax Fund

Parks & Open Space

132046 CONSTRUCTION TESTING SERVICES	TESTING SERVICES	3,635.00
132106 STORMWATER SPECIALISTS	INSPECTION SERVICES	1,530.00

Streets

132040 BAY AREA NEWS GROUP	LEGAL AD	259.66
----------------------------	----------	--------

214 Animal Control Fund

Animal Control

131947 ANIMAL CARE EQUIPMENT & SERVICES	SUPPLIES	98.25
131976 EAST BAY VETERINARY EMERGENCY	VETERINARY SERVICES	38.42
131977 EAST HILLS VETERINARY HOSPITAL	VETERINARY SERVICES	87.80
131995 KOEFRAN SERVICES INC	ANIMAL DISPOSAL SERVICES	1,850.00
132007 OFFICE MAX INC	OFFICE SUPPLIES	57.72
132083 MWI VETERINARY SUPPLY CO	VETERINARY PHARMACEUTICALS	873.85

Prepared by: Georgina Meek
 Finance Accounting

CITY OF ANTIOCH
 CLAIMS BY FUND REPORT
 FOR THE PERIOD OF
 FEBRUARY 9-22, 2012
 FUND/CHECK#

132093 PFIZER ANIMAL HEALTH	ANIMAL CARE SUPPLIES	238.05
219 Recreation Fund		
Non Departmental		
131992 KANDEL, DAVID	DEPOSIT REFUND	800.00
132010 PELAYO, AURORA	DEPOSIT REFUND	270.00
132015 RAINBOW FACTORY	CANCELLATION REFUND	470.00
132082 MUNOZ, PATRICIA	DEPOSIT REFUND	625.00
132090 PACHECO BROTHERS GARDENING INC	LANDSCAPE SERVICES	1,835.00
Recreation Admin		
131952 AT AND T MCI	PHONE	62.85
131981 FERTADO HEATING AND AIR INC	REPAIR SERVICE	136.50
131990 IN DEMAND PLUMBING	PLUMBING SERVICES	1,455.00
Senior Programs		
131953 AT AND T MCI	PHONE	95.48
131996 LENHART ALARM AND SECURITY	ALARM SERVICE	172.61
Recreation Classes/Prog		
132000 MCINROY, LINH	CLASS REFUND	105.50
132019 STARGAZERS/TRACI MARTIN	CONTRACTOR PAYMENT	915.00
201474 MIRANDA, MARIA	CLASS REFUND	14.00
201475 CARDINALE, BRITANY	CLASS REFUND	46.00
201476 CARDINALE, BRITANY	CLASS REFUND	46.00
201477 ANDRIEIEVA, VIKIORIIA	CLASS REFUND	24.00
201478 BERAN, JAMIE	CLASS REFUND	3.00
201479 BETTHANY, EILEEN	CLASS REFUND	27.00
201480 YOUNGBLOOD BRIDGEMAN, YVONNE	CLASS REFUND	27.00
201481 PARKINSON, JENNILEE	CLASS REFUND	93.00
Recreation Sports Programs		
131960 BELUS, MAIA	DEPOSIT REFUND	372.00
131979 EDD	UNEMPLOYMENT CLAIMS	386.00
Recreation Teens		
131979 EDD	UNEMPLOYMENT CLAIMS	122.00
Rec After School/AUSD		
131979 EDD	UNEMPLOYMENT CLAIMS	4,369.00
Recreation-New Comm Cntr		
131981 FERTADO HEATING AND AIR INC	FREEZER REPAIR	410.00
132010 PELAYO, AURORA	DEPOSIT REFUND	530.00
132067 HILLYARD INDUSTRIES	JANITORIAL SUPPLIES	1,085.65
132090 PACHECO BROTHERS GARDENING INC	LANDSCAPE SERVICES	5,636.68
132091 PACIFIC GAS AND ELECTRIC CO	ELECTRIC	6,459.57
226 Solid Waste Reduction Fund		
Solid Waste Used Oil		
131944 ALLIED WASTE SERVICES	OIL COLLECTION SERVICE	1,597.38
229 Pollution Elimination Fund		
Channel Maintenance Operation		
131984 HAGEMEYER	SUPPLIES	1,392.49
132005 NEXTEL SPRINT	CELL PHONE	98.38

Prepared by: Georgina Meek
 Finance Accounting

2/23/2012

CITY OF ANTIOCH
 CLAIMS BY FUND REPORT
 FOR THE PERIOD OF
 FEBRUARY 9-22, 2012
 FUND/CHECK#

916721 JOHN DEERE LANDSCAPES ANTIOCH	IRRIGATION CONTROLLER PARTS	221.80
238 PEG Franchise Fee Fund		
<i>Non Departmental</i>		
132043 CHARLES M SAULTER ASSOCIATES INC	PROFESSIONAL SERVICES	153.90
251 Lone Tree SLLMD Fund		
<i>Lonetree Maintenance Zone 1</i>		
131953 AT AND T MCI	PHONE	62.44
132085 ODYSSEY LANDSCAPE CO INC	LANDSCAPE SERVICES	96.00
<i>Lonetree Maintenance Zone 2</i>		
131953 AT AND T MCI	PHONE	121.00
<i>Lonetree Maintenance Zone 3</i>		
131953 AT AND T MCI	PHONE	46.21
252 Downtown SLLMD Fund		
<i>Downtown Maintenance</i>		
132085 ODYSSEY LANDSCAPE CO INC	LANDSCAPE SERVICES	192.00
254 Hillcrest SLLMD Fund		
<i>Hillcrest Maintenance Zone 1</i>		
131953 AT AND T MCI	PHONE	31.22
132085 ODYSSEY LANDSCAPE CO INC	LANDSCAPE SERVICES	230.40
<i>Hillcrest Maintenance Zone 2</i>		
131953 AT AND T MCI	PHONE	123.79
132085 ODYSSEY LANDSCAPE CO INC	LANDSCAPE SERVICES	480.00
132105 STEWARTS TREE SERVICE	TREE SERVICE	550.00
<i>Hillcrest Maintenance Zone 4</i>		
131953 AT AND T MCI	PHONE	91.12
132085 ODYSSEY LANDSCAPE CO INC	LANDSCAPE SERVICES	153.60
255 Park 1A Maintenance District Fund		
<i>Park 1A Maintenance District</i>		
131953 AT AND T MCI	PHONE	15.96
132085 ODYSSEY LANDSCAPE CO INC	LANDSCAPE SERVICES	230.40
256 Citywide 2A Maintenance District Fund		
<i>Citywide 2A Maintenance Zone 6</i>		
132085 ODYSSEY LANDSCAPE CO INC	LANDSCAPE SERVICES	192.00
<i>Citywide 2A Maintenance Zone 9</i>		
131953 AT AND T MCI	PHONE	62.44
132085 ODYSSEY LANDSCAPE CO INC	LANDSCAPE SERVICES	153.60
<i>Citywide 2A Maintenance Zone10</i>		
132105 STEWARTS TREE SERVICE	TREE SERVICE	1,300.00
257 SLLMD Administration Fund		
<i>SLLMD Administration</i>		
132005 NEXTEL SPRINT	CELL PHONE	241.04
132089 ORCHARD SUPPLY HARDWARE	SUPPLIES	14.06
259 East Lone Tree SLLMD Fund		
<i>Zone 1-District 10</i>		
132105 STEWARTS TREE SERVICE	TREE SERVICE	1,600.00

CITY OF ANTIOCH
 CLAIMS BY FUND REPORT
 FOR THE PERIOD OF
 FEBRUARY 9-22, 2012
 FUND/CHECK#

311 Capital Improvement Fund

Measure WW

132072 KARSTE CONSULTING INC CONSULTING SERVICES 720.00

Streets

131999 MAXICRETE INC SIDEWALK PROJECT 13,411.51

Public Buildings & Facilities

132072 KARSTE CONSULTING INC CONSULTING SERVICES 3,000.00

916724 NICHOLS CONSULTING ENGINEERS CORP PROJECT MANAGEMENT 1,828.75

570 Equipment Maintenance Fund

Non Departmental

131988 HUNT AND SONS INC FUEL 17,104.08

Equipment Maintenance

131949 ANTIOCH GLASS GLASS INSTALLATION 466.50

131968 CONTRA COSTA COUNTY RADIO SERVICES 210.00

132032 ALL STAR AUTO ELECTRIC STOCK SUPPLY 409.68

132035 ANTIOCH AUTO PARTS AUTO PARTS STOCK 121.49

132039 BAY AREA AIR QUALITY MANAGEMENT PERMIT FEE 1,239.00

132044 CHUCKS BRAKE AND WHEEL SERVICE STARTER SOLENOID 433.80

132058 EAST BAY TIRE CO TIRE MOUNT 79.85

132078 MITCHELL ONE INC DIAGNOSTIC INFORMATION 3,672.00

132108 TRED SHED, THE TIRES 3,874.57

132114 WALNUT CREEK FORD SUPPLIES 1,245.56

916712 DAN FARIAS MOBILE SMOKE CHECK SMOG TESTS 250.00

573 Information Services Fund

Information Services

131953 AT AND T MCI PHONE 57.39

131957 BARTON, T ALAN SUPPLIES REIMBURSEMENT 55.00

132005 NEXTEL SPRINT CELL PHONE 98.38

Network Support & PCs

131953 AT AND T MCI PHONE 92.54

132005 NEXTEL SPRINT CELL PHONE 218.81

132056 DIGITAL SERVICES WEBSITE MAINTENANCE 2,255.00

Telephone System

131951 AT AND T MCI PHONE 20.35

131952 AT AND T MCI PHONE 162.83

131953 AT AND T MCI PHONE 2,280.86

132005 NEXTEL SPRINT CELL PHONE EQUIPMENT 253.61

GIS Support Services

131963 CALIF SURVEYING AND DRAFTING SOFTWARE 8,215.78

Office Equipment Replacement

131964 CAPTURE TECHNOLOGIES INC DISPATCH RECORDING UNITS 21,454.49

132066 HEWLETT PACKARD COMPANY COMPUTER EQUIPMENT 3,636.31

577 Post Retirement Medical-Police Fund

Non Departmental

132013 PERS PAYROLL DEDUCTIONS 3,357.22

CITY OF ANTIOCH
 CLAIMS BY FUND REPORT
 FOR THE PERIOD OF
 FEBRUARY 9-22, 2012
 FUND/CHECK#

578 Post Retirement Medical-Misc Fund

Non Departmental

132013 PERS	PAYROLL DEDUCTIONS	6,294.89
132025 RETIREE	MEDICAL AFTER RETIREMENT	697.71

579 Post Retirement Medical-Mgmt Fund

Non Departmental

132013 PERS	PAYROLL DEDUCTIONS	8,383.27
-------------	--------------------	----------

580 Loss Control Fund

Human Resources

131989 IEDA INC	MEMBER DUES	3,884.46
132005 NEXTEL SPRINT	CELL PHONE	42.18

611 Water Fund

Non Departmental

131998 LOWES COMPANIES INC	SUPPLIES	604.55
132007 OFFICE MAX INC	OFFICE SUPPLIES	1,812.55
132016 ROBERTS AND BRUNE CO	SUPPLIES	232.01
132065 GOLOGO PROMOTIONS	SUPPLIES	545.58
132116 WESCO RECEIVABLES CORP	SUPPLIES	187.27
916713 AIRGAS NCN	CYLINDER RENTAL	165.42

Water Supervision

132005 NEXTEL SPRINT	CELL PHONE	123.41
132097 RUGG, STEVE	CHECK REPLACEMENT	25.33

Water Production

131943 ALLIED PACKING AND SUPPLY INC	EXPANSION JOINT	1,178.63
131946 AWWA	REGISTRATION FEES	920.00
131952 AT AND T MCI	PHONE	125.72
131953 AT AND T MCI	PHONE	817.58
131957 BARTON, T ALAN	SUPPLIES REIMBURSEMENT	119.61
131961 BIGGE CRANE AND RIGGING CO INC	CRANE RENTAL	880.00
131998 LOWES COMPANIES INC	TARP	43.28
132005 NEXTEL SPRINT	CELL PHONE	126.54
132016 ROBERTS AND BRUNE CO	VALVES & GASKETS	1,843.44
132024 UNIVAR USA INC	CAUSTIC	6,576.33
132026 WESCO RECEIVABLES CORP	SUPPLIES	200.26
132027 WESTERN SCIENTIFIC	EQUIPMENT REPAIR	626.00
132030 ACE HARDWARE, ANTIOCH	HINGES	29.13
132061 FISHER SCIENTIFIC COMPANY	LAB SUPPLIES	435.26
132062 FLOW SCIENCE INCORPORATED	PROFESSIONAL SERVICES	345.00
132063 FLW INC	PSI/VAC GAUGE	540.36
132064 GERLINGER STELL & SUPPLY	EXPANDED METAL	413.52
132069 ICR ELECTRICAL CONTRACTORS	ELECTRICAL SERVICES	440.18
132071 KARL NEEDHAM ENTERPRISES INC	RENTAL EQUIPMENT	28,775.14
132089 ORCHARD SUPPLY HARDWARE	SUPPLIES	30.27
132100 SPAULDING, ANN B	CONSULTING SERVICE	2,739.43
132110 UNIVAR USA INC	CAUSTIC	6,672.99
132116 WESCO RECEIVABLES CORP	SUPPLIES	200.26

Prepared by: Georgina Meek
 Finance Accounting

CITY OF ANTIOCH
 CLAIMS BY FUND REPORT
 FOR THE PERIOD OF
 FEBRUARY 9-22, 2012
 FUND/CHECK#

916719 GENERAL CHEMICAL CORP	ALUM	9,763.02
Water Distribution		
131953 AT AND T MCI	PHONE	15.61
131985 HANBERG, BRETT K	EXPENSE REIMBURSEMENT	27.03
132005 NEXTEL SPRINT	CELL PHONE	711.85
132007 OFFICE MAX INC	OFFICE SUPPLIES	14.50
132016 ROBERTS AND BRUNE CO	PIPE & FITTINGS	840.01
132030 ACE HARDWARE, ANTIOCH	OIL	6.32
132036 ANTIOCH BUILDING MATERIALS	ASPHALT MATERIALS	17,798.20
132038 BACKFLOW APPARATUS AND VALVE CO	BACKFLOW REPAIR	4,009.90
132042 CHADWICK, JEFFREY D	EXPENSE REIMBURSEMENT	32.46
132049 CONTRA COSTA HOSE AND FITTINGS	AIR HOSE REPAIR	139.70
132055 DEPT OF PUBLIC HEALTH	RENEWAL-HANBERG	160.00
132072 KARSTE CONSULTING INC	CONSULTING SERVICES	2,400.00
132086 OFFICE MAX INC	OFFICE SUPPLIES	42.05
132089 ORCHARD SUPPLY HARDWARE	SUPPLIES	69.25
132105 STEWARTS TREE SERVICE	TREE SERVICE	500.00
Water Meter Reading		
132005 NEXTEL SPRINT	CELL PHONE	21.07
Warehouse & Central Stores		
132005 NEXTEL SPRINT	CELL PHONE	98.38
132022 UNITED PARCEL SERVICE	WEEKLY PRINTER SERVICE FEE	12.00
612 Water Line Expansion Fund		
Water Systems		
132001 MERITAGE HOMES OF NO CALIFORNIA	WATER CAPACITY FEE REFUND	29,708.37
916725 TESTING ENGINEERS INC	TESTING SERVICE	230.00
621 Sewer Fund		
Sewer-Wastewater Supervision		
132005 NEXTEL SPRINT	CELL PHONE	42.18
132052 CWEA SFBS	RENEWAL - SAINS	132.00
Sewer-Wastewater Collection		
131953 AT AND T MCI	PHONE	31.62
131984 HAGEMeyer	SUPPLIES	2,000.00
132005 NEXTEL SPRINT	CELL PHONE	183.14
132007 OFFICE MAX INC	OFFICE SUPPLIES	6.79
132036 ANTIOCH BUILDING MATERIALS	ASPHALT MATERIALS	890.20
132051 CWEA SFBS	REGISTRATION-CHALK	60.00
132086 OFFICE MAX INC	OFFICE SUPPLIES	42.05
132115 WECO INDUSTRIES INC	SUPPLIES	87.65
132116 WESCO RECEIVABLES CORP	SUPPLIES	80.02
Wastewater Collection		
132096 RMC WATER AND ENVIRONMENT	DOCUMENT PREPARATION	7,713.87
631 Marina Fund		
Marina Administration		
131953 AT AND T MCI	PHONE	66.11
201415 DEPARTMENT OF MOTOR VEHICLES	LIEN SALE FEE	8.00

Prepared by: Georgina Meek
 Finance Accounting

CITY OF ANTIOCH
 CLAIMS BY FUND REPORT
 FOR THE PERIOD OF
 FEBRUARY 9-22, 2012
 FUND/CHECK#

Marina Maintenance

131959 BELUS CONSTRUCTION	DOOR REPAIR	1,350.00
132007 OFFICE MAX INC	OFFICE SUPPLIES	128.02
132057 DOGGIE WALK BAGS INC	DOGGIE BAGS	286.70

Major Projects

131958 BAY CITIES PAVING AND GRADING	MARINA BOAT LAUNCH PROJECT	785,948.03
916725 TESTING ENGINEERS INC	TESTING SERVICES	2,040.00

641 Prewett Water Park Fund

Non Departmental

131950 ASSOCIATED OF UGANDAN COMMUNITY	DEPOSIT REFUND	500.00
--	----------------	--------

Rec - Prewett Admin

131953 AT AND T MCI	PHONE	90.20
131965 COMCAST	MONTHLY DMX SERVICE	48.56
131979 EDD	UNEMPLOYMENT CLAIMS	800.00
131986 HILLYARD INDUSTRIES	SUPPLIES	55.21
131994 KNORR SYSTEMS INC	CARBON DIOXIDE	270.21
131998 LOWES COMPANIES INC	SUPPLIES	56.05
132073 KNORR SYSTEMS INC	CARBON DIOXIDE	59.45
132090 PACHECO BROTHERS GARDENING INC	LANDSCAPE SERVICES	3,758.32
201370 STAPLES	OFFICE SUPPLIES	39.28
916708 CALIFORNIA DIESEL AND POWER INC	GENERATOR SERVICE	675.00

Recreation Aquatics

201369 MOORE, MELISSA	CLASS REFUND	10.00
-----------------------	--------------	-------

Rec Prewett Concessions

131997 LISTEK ENTERPRISES INC	PARTY PIZZA	159.36
-------------------------------	-------------	--------

721 Employee Benefits Fund

Non Departmental

132012 PERS	PAYROLL DEDUCTIONS	267,169.39
132013 PERS	PAYROLL DEDUCTIONS	264,624.69
132041 EMPLOYEE	GARNISHMENT REIMBURSEMENT	1,013.00
132045 CLAYTON FITNESS CENTER	PAYROLL DEDUCTIONS	34.00
132047 CONTRA COSTA COUNTY	PAYROLL DEDUCTIONS	50.00
132048 CONTRA COSTA COUNTY	PAYROLL DEDUCTIONS	400.00
132053 DELTA PARK ATHLETIC CLUB	PAYROLL DEDUCTIONS	74.00
132054 DELTA VALLEY ATHLETIC CLUB	PAYROLL DEDUCTIONS	54.00
132070 IN SHAPE HEALTH CLUBS	PAYROLL DEDUCTIONS	1,136.00
132076 LINA	PAYROLL DEDUCTIONS	4,549.92
132080 MUNICIPAL POOLING AUTHORITY	PAYROLL DEDUCTIONS	2,277.96
132087 OPERATING ENGINEERS LOCAL NO 3	PAYROLL DEDUCTIONS	2,080.00
132088 OPERATING ENGINEERS LOCAL NO 3	PAYROLL DEDUCTIONS	549.17
132092 PERS LONG TERM CARE	PAYROLL DEDUCTIONS	92.66
132094 PERS	PAYROLL DEDUCTIONS	255,797.70
132095 PUBLIC EMPLOYEES UNION LOCAL 1	PAYROLL DEDUCTIONS	2,147.35
132099 SOLAR SWIM AND GYM	PAYROLL DEDUCTIONS	27.00
132101 STANDARD LIFE INSURANCE	PAYROLL DEDUCTIONS	691.30
132102 STATE OF CALIFORNIA	PAYROLL DEDUCTIONS	1,013.00

Prepared by: Georgina Meek
 Finance Accounting

2/23/2012

CITY OF ANTIOCH
 CLAIMS BY FUND REPORT
 FOR THE PERIOD OF
 FEBRUARY 9-22, 2012
 FUND/CHECK#

132103 STATE OF CALIFORNIA	PAYROLL DEDUCTIONS	196.40
132104 STATE OF FLORIDA DISBURSEMENT UNIT	PAYROLL DEDUCTIONS	150.00
132109 UNION BANK OF CALIF	PAYROLL DEDUCTIONS	3,354.15
132112 US DEPT OF EDUCATION	PAYROLL DEDUCTIONS	264.25
132113 VANTAGEPOINT TRANSFER AGENTS	PAYROLL DEDUCTIONS	1,687.48
132117 XTREME FITNESS	PAYROLL DEDUCTIONS	169.50
916715 ANTIOCH PD SWORN MGMT ASSOC	PAYROLL DEDUCTIONS	600.00
916716 APOA	PAYROLL DEDUCTIONS	11,760.17
916723 NATIONWIDE RETIREMENT SOLUTIONS	PAYROLL DEDUCTIONS	45,635.86

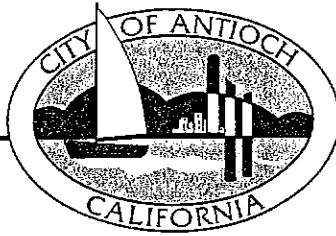

STAFF REPORT TO THE CITY COUNCIL
FOR CONSIDERATION AT THE COUNCIL MEETING OF FEBRUARY 28, 2012

SUBMITTED BY: Donna Conley, City Treasurer *DC*
DATE: February 22, 2012
SUBJECT: Treasurer's Report – JANUARY 2012

RECOMMENDATION: Review and file.

C

2-28-2012

CITY OF ANTIOCH
SUMMARY REPORT ON THE CITY'S INVESTMENTS

JANUARY 31, 2012

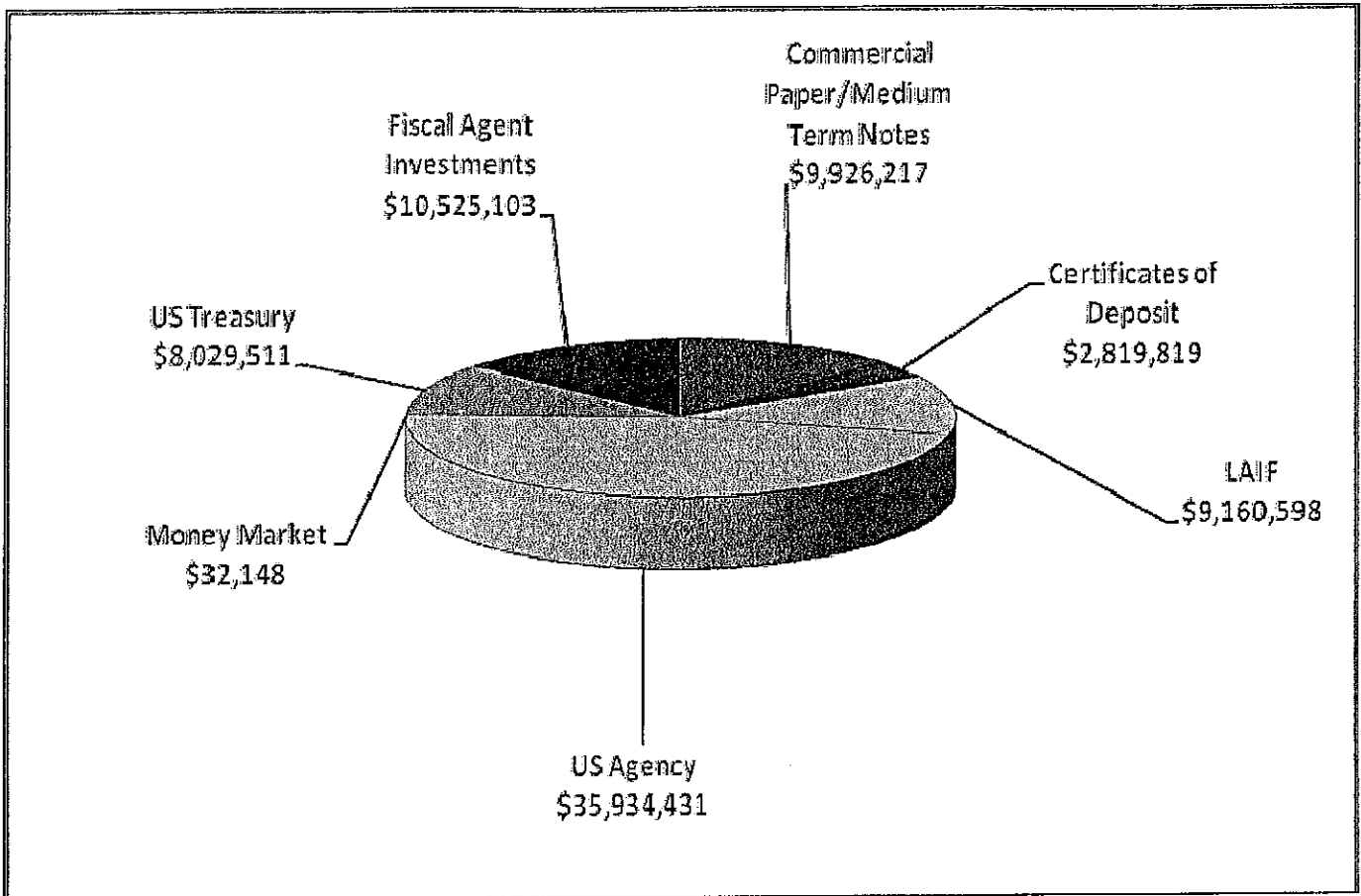

Total of City and Fiscal Agent Investments = \$76,427,827

All City investments are shown above and conform to the City Investment Policy. All investment transactions during this period are included in this report. As Treasurer of the City of Antioch and Finance Director of the City of Antioch, we hereby certify that sufficient investment liquidity and anticipated revenue are available to meet the next six (6) months' estimated expenditures.

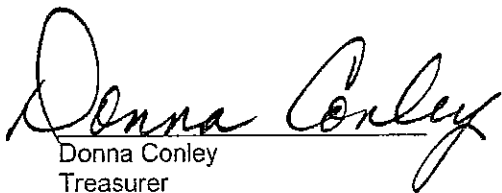
Donna Conley
Treasurer

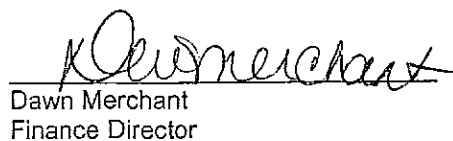
Dawn Merchant
Finance Director

**Summary of Fiscal Agent Balances by
Debt Issue**

	<u>Amount</u>
Antioch Public Financing Authority 2003 Water Revenue Bonds	1,224,114
Antioch Public Financing Authority 2002 Lease Revenue Bonds	8,752
Antioch Public Financing Authority 1998 Reassessment Revenue Bonds	8,630,602
Antioch Development Agency 2009 Tax Allocation Bonds	146,024
Antioch Development Agency 2000 Tax Allocation Bonds	83,019
ABAG Lease Revenue Bonds	<u>432,592</u>
	<u><u>\$10,525,103</u></u>



Managed Account Summary Statement

For the Month Ending January 31, 2012

CITY OF ANTIPOCH, CA 04380500

Transaction Summary - Managed Account

Opening Market Value	\$53,741,066.60
Maturities/Calls	0.00
Principal Dispositions	(2,315,363.27)
Principal Acquisitions	5,337,322.90
Unsettled Trades	0.00
Change in Current Value	84,402.07
Closing Market Value	\$56,847,428.30

Cash Transactions Summary - Managed Account

Maturities/Calls	0.00
Sale Proceeds	2,323,908.90
Coupon/Interest Income	30,000.01
Principal Payments	0.00
Security Purchases	(5,340,201.15)
Net Cash Contribution	3,000,000.00
Reconciling Transactions	0.00

Earnings Reconciliation (Cash Basis) - Managed Account

Interest/Coupons Received	38,545.64
Less Purchased Interest Related to Interest/Coupons	(2,878.25)
Plus Net Realized Gains/Losses	15,752.08
Total Cash Basis Earnings	\$51,419.47

Cash Balance

Closing Cash Balance \$32,148.31

Earnings Reconciliation (Accrual Basis)

Ending Amortized Value of Securities	56,490,159.00
Ending Accrued Interest	220,429.47
Plus Proceeds from Sales	2,323,908.90
Plus Proceeds of Maturities/Calls/Principal Payments	0.00
Plus Coupons Received	30,000.01
Less Cost of New Purchases	(5,340,201.15)
Less Beginning Amortized Value of Securities	(53,476,006.40)
Less Beginning Accrued Interest	(193,111.88)

Total Accrual Basis Earnings

\$55,177.95



Managed Account: Issuer Summary

For the Month Ending January 31, 2012

CITY OF ANTIOCH, CA - 04380500

Issuer Summary

Issuer	Market Value of Holdings	Percent
BANK OF NEW YORK	1,065,266.00	1.87
BERKSHIRE HATHAWAY INC	856,943.65	1.51
CATERPILLAR INC	533,002.40	0.94
DEERE & COMPANY	509,300.50	0.90
FANNIE MAE	18,658,907.75	32.81
FEDERAL HOME LOAN BANKS	5,112,189.60	8.99
FREDDIE MAC	11,749,642.67	20.67
GENERAL ELECTRIC CO	2,220,299.75	3.91
IBM CORP	826,041.62	1.45
JOHNSON & JOHNSON	1,017,728.00	1.79
JP MORGAN CHASE & CO	1,083,479.52	1.91
PROCTER & GAMBLE CO	503,170.50	0.89
ROYAL BANK OF CANADA	1,299,896.14	2.29
SAN FRANCISCO CALIF CITY & CNTY (AMBAC)	597,180.20	1.05
TORONTO-DOMINION BANK	1,299,593.31	2.29
UNITED STATES TREASURY	8,060,888.85	14.18
WAL-MART STORES INC	416,585.84	0.73
WELLS FARGO & COMPANY	1,037,312.00	1.82
Total	\$56,847,428.30	100.00%

Credit Quality (S&P Ratings)

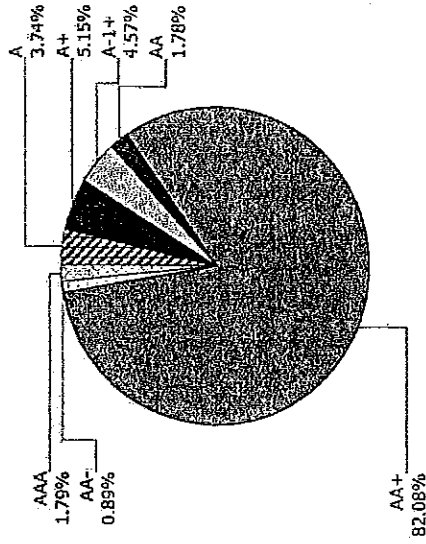



Managed Account Detail of Securities Held For the Month Ending January 31, 2012

CITY OF ANTIPOCH, CA 04380500

Security Type/Description	Dated Date/Coupon/Maturity	CUSIP	S&P Rating	Moody's Rating	Trade Date	Settle Date	Original Cost	YTM at Cost	Accrued Interest	Amortized Cost	Market Value
U.S. Treasury Bond / Note											
US TREASURY NOTES	01/31/2011 0.625% 01/31/2013	912828PRL5	AA+	Aaa	02/01/11	02/04/11	2,025,028.33	0.60	34.77	2,025,517.23	2,034,412.20
US TREASURY NOTES	03/31/2009 1.750% 03/31/2014	912828KJ8	AA+	Aaa	10/27/11	10/31/11	3,098,085.94	0.39	17,786.89	3,087,808.77	3,098,436.00
US TREASURY NOTES	07/15/2011 0.625% 07/15/2014	912828OU7	AA+	Aaa	11/02/11	11/07/11	579,492.19	0.33	167.84	579,102.57	580,165.80
US TREASURY NOTES	09/15/2011 0.250% 09/15/2014	912828RG7	AA+	Aaa	10/12/11	10/14/11	1,140,701.17	0.53	1,097.87	1,141,657.23	1,149,281.25
US TREASURY N/B	12/15/2011 0.250% 12/15/2014	912828RVA	AA+	Aaa	01/05/12	01/06/12	1,195,312.50	0.38	393.44	1,195,425.24	1,198,593.60
Security Type Sub-Total							8,039,620.12	0.46	19,480.81	8,029,511.04	8,060,888.85

Municipal Bond / Note											
SAN FRANCISCO CITY & CNTY GO MUNI NOTES		797646PU4	AA	Aa2	11/10/11	11/30/11	254,994.10	0.68	1,948.61	253,339.34	254,550.20
DTD 11/30/2011 5.000% 06/15/2014											
SAN FRANCISCO CITY & CNTY GO MUNI NOTES		797646PV2	AA	Aa2	11/10/11	11/30/11	341,313.00	1.03	2,541.67	339,367.25	342,630.00
DTD 11/30/2011 5.000% 06/15/2015											
Security Type Sub-Total							596,307.10	0.88	4,490.28	592,706.59	597,180.20

Federal Agency Bond / Note											
FHLMC NOTES		3137EACS6	AA+	Aaa	03/25/11	03/28/11	1,846,411.00	0.85	4,740.63	1,847,914.38	1,861,127.75
DTD 02/04/2011 0.750% 03/28/2013											
FHLMC GLOBAL NOTES		3137EACJ6	AA+	Aaa	03/03/10	03/04/10	2,132,011.00	1.67	10,215.38	2,133,819.88	2,170,430.33
DTD 03/04/2010 1.625% 04/15/2013											
FHLMC GLOBAL REFERENCE NOTES		3137EABJ7	AA+	Aaa	03/19/10	03/22/10	604,854.00	1.81	3,465.97	587,650.21	599,644.50
DTD 03/14/2008 3.500% 05/29/2013											



PFM Asset Management LLC



For the Month Ending January 31, 2012

Managed Account Detail of Securities Held

CITY OF ANTIPOH, CA 04380500

Security Type/Description	Dated Date/Coupon/Maturity	CUSIP	Par	S&P Rating	Moody's Rating	Trade Date	Settle Date	Original Cost	YTM at Cost	Accrued Interest	Amortized Cost	Market Value
Federal Agency Bond / Note												
FNMA NOTES	DTD 06/17/2011 0.500% 08/09/2013	3135G0BR3	2,980,000.00	AA+	Aaa	11/16/11	11/17/11	2,983,129.00	0.44	7,118.89	2,982,759.54	2,988,844.64
FNMA NOTES	DTD 07/09/2010 1.250% 08/29/2013	31398AX31	2,500,000.00	AA+	Aaa	03/31/11	03/31/11	2,511,400.00	1.06	13,975.69	2,507,455.28	2,535,182.50
FHLB GLOBAL NOTES	DTD 07/21/2011 0.500% 08/28/2013	313374Y61	2,075,000.00	AA+	Aaa	07/20/11	07/21/11	2,072,115.75	0.57	4,409.38	2,072,835.67	2,080,245.60
FNMA NOTES (CALLABLE)	DTD 09/19/2011 0.500% 09/19/2013	3135G0DE0	2,300,000.00	AA+	Aaa	09/01/11	09/19/11	2,300,000.00	0.50	4,216.67	2,300,000.00	2,300,361.10
FANNIE MAE GLOBAL NOTES	DTD 08/06/2010 1.000% 09/23/2013	31398A250	1,825,000.00	AA+	Aaa	03/02/11	03/03/11	1,820,182.00	1.11	6,488.89	1,821,886.31	1,844,459.98
FREDDIE MAC GLOBAL NOTES	DTD 10/20/2011 0.500% 10/15/2013	3134G23H3	1,845,000.00	AA+	Aaa	10/20/11	10/21/11	1,844,372.70	0.52	2,588.13	1,844,460.15	1,843,896.69
FNMA GLOBAL BENCHMARK NOTES	DTD 09/26/2003 4.625% 10/15/2013	31359MTG8	2,775,000.00	AA+	Aaa	07/29/11	08/03/11	3,020,687.40	0.57	37,790.10	2,965,735.02	2,977,472.33
FNMA GLOBAL NOTES	DTD 02/01/2011 1.250% 02/27/2014	3135G0AP8	1,900,000.00	AA+	Aaa	03/17/11	03/18/11	1,903,876.00	1.18	10,159.72	1,902,746.64	1,928,564.60
FNMA GLOBAL NOTES	DTD 07/18/2011 0.875% 08/28/2014	3135G0BP8	3,450,000.00	AA+	Aaa	11/28/11	11/30/11	3,499,990.50	0.60	18,447.92	3,496,239.38	3,501,867.30
FHLMC NOTES	DTD 08/12/2011 0.500% 09/19/2014	3134G2YJ5	1,600,000.00	AA+	Aaa	09/20/11	09/21/11	1,597,863.68	0.55	2,933.33	1,598,119.60	1,597,158.40
FREDDIE MAC GLOBAL NOTES	DTD 08/05/2011 0.750% 09/22/2014	3134G2WG3	910,000.00	AA+	Aaa	09/28/11	09/30/11	911,820.00	0.68	2,445.63	911,616.46	914,322.50
FREDDIE MAC GLOBAL NOTES	DTD 08/05/2011 0.750% 09/22/2014	3134G2WG3	2,750,000.00	AA+	Aaa	08/30/11	08/31/11	2,764,410.00	0.58	7,390.63	2,762,460.11	2,763,062.50
FHLB NOTES	DTD 11/08/2010 0.875% 12/12/2014	313371PC4	3,000,000.00	AA+	Aaa	01/19/12	01/19/12	3,028,170.00	0.55	3,572.92	3,027,848.31	3,031,944.00

Security Type Sub-Total 35,045,000.00 35,419,881.03 0.75 142,098.16 35,341,724.49 35,520,740.02

Account 04380500 Page 5



PFM Asset Management LLC



Managed Account Detail of Securities Held

For the Month Ending January 31, 2012

CITY OF ANTIPOCH, CA - 04380500

Security Type/Description	Dated Date/Coupon/Maturity	CUSIP	Par	S&P Rating	Moody's Rating	Trade Date	Settle Date	Original Cost	YTM at Cost	Accrued Interest	Amortized Cost	Market Value
Corporate Note												
GENERAL ELECTRIC CAPITAL CORP (FLOAT)	3696ZGZ49		1,080,000.00	AA+	Aa2	01/19/10	01/22/10	1,056,457.08	1.22	1,544.05	1,074,844.73	1,080,641.52
NT												
DTD 11/01/2006 0.677% 11/01/2012												
WELLS FARGO & COMPANY GLOBAL SR	949746NY3		1,000,000.00	A+	A2	01/20/11	01/25/11	1,058,400.00	1.42	121.53	1,029,127.27	1,037,312.00
NOTES												
DTD 01/31/2008 4.375% 01/31/2013												
BANK OF NEW YORK MELLON SR NOTES	06406HBK4		1,000,000.00	A+	Aa2	04/05/11	04/08/11	1,086,260.00	1.43	21,923.61	1,057,169.85	1,065,266.00
DTD 08/27/2008 5.125% 08/27/2013												
JOHN DEERE CAPITAL CORP NOTE	24422ERA9		500,000.00	A	A2	02/28/11	03/03/11	499,505.00	1.63	3,288.89	499,652.84	509,300.50
DTD 03/03/2011 1.600% 03/03/2014												
CATERPILLAR FINANCIAL SE CORP NOTE	14912L4T5		250,000.00	A	A2	03/24/11	04/01/11	250,197.50	1.62	1,375.00	250,143.57	253,900.50
DTD 04/01/2011 1.650% 04/01/2014												
WAL MART STORES INC. CORP NOTES	931142DA8		405,000.00	AA	Aa2	04/11/11	04/18/11	403,906.50	1.72	1,937.81	404,188.45	416,585.84
DTD 04/18/2011 1.625% 04/15/2014												
IBM CORP GLOBAL NOTES	459200GW5		815,000.00	A+	Aa3	05/09/11	05/12/11	814,233.90	1.28	2,235.59	814,415.05	826,041.62
DTD 05/12/2011 1.250% 05/12/2014												
JOHNSON & JOHNSON GLOBAL NOTE	478160AXZ		1,000,000.00	AAA	Aaa	05/17/11	05/20/11	998,830.00	1.24	2,533.33	999,099.09	1,017,728.00
DTD 05/20/2011 1.200% 05/15/2014												
CATERPILLAR FINANCIAL SE NOTES	14912L4V0		275,000.00	A	A2	05/17/11	05/20/11	274,854.25	1.39	745.75	274,887.60	279,101.90
DTD 05/20/2011 1.375% 05/20/2014												
JP MORGAN CHASE & CO NOTES	46625HHN3		1,010,000.00	A	Aa3	12/19/11	12/22/11	1,062,853.30	2.43	7,827.50	1,060,567.48	1,083,479.52
DTD 05/18/2009 4.650% 06/01/2014												
PROCTER & GAMBLE CO CORP NOTES	742718DU0		500,000.00	AA-	Aa3	08/10/11	08/15/11	497,945.00	0.84	1,613.89	498,257.57	503,170.50
DTD 08/15/2011 0.700% 08/15/2014												
BERKSHIRE HATHAWAY INC (FLOATING)	084670BA5		850,000.00	AA+	Aa2	08/10/11	08/15/11	850,000.00	0.98	2,131.21	850,000.00	856,943.65
NOTES												
DTD 08/15/2011 1.157% 08/15/2014												
GENERAL ELEC CAP CORP GLOBAL NOTES	3696ZG5M2		1,115,000.00	AA+	Aa2	01/09/12	01/09/12	1,113,840.40	2.19	1,464.99	1,113,863.38	1,139,658.23
DTD 01/09/2012 2.150% 01/09/2015												



PFM Asset Management LLC



Managed Account Detail of Securities Held

For the Month Ending January 31, 2012

CITY OF ANTIPOCH, CA 04380500

Security Type/Description	Dated Date/Coupon/Maturity	CUSIP	S&P Rating	Moody's Rating	Trade Date	Settle Date	Original Cost	YTM at Cost	Accrued Interest	Amortized Cost	Market Value
Certificate of Deposit											
TORONTO DOMINION BANK NY CERT			A-1+	P-1	08/12/11	08/16/11	1,300,000.00	0.45	2,746.24	1,300,000.00	1,299,593.31
DEPOS											
DTD 08/16/2011 0.450% 08/13/2012											
ROYAL BANK OF CANADA NY CERT DEPOS			A-1+	P-1	08/23/11	08/26/11	1,300,000.00	0.50	2,870.83	1,300,000.00	1,299,896.14
DEPOS											
DTD 08/26/2011 0.500% 08/24/2012											
Security Type Sub-Total							2,600,000.00	0.48	5,617.07	2,600,000.00	2,599,489.45
Managed Account Sub-Total							55,925,000.00	0.84	220,429.47	56,490,159.00	56,847,428.30
Securities Sub-Total							\$55,925,000.00	0.84%	\$220,429.47	\$56,490,159.00	\$56,847,428.30
Accrued Interest											\$220,429.47
Total Investments											\$57,067,857.77





Managed Account Security Transactions & Interest

For the Month Ending January 31, 2012

CITY OF ANTIPOCH, CA - 04380500

Transaction Type	Trade	Settle	Security Description	CUSIP	Par	Principal Proceeds	Accrued Interest	Total	Realized G/L Cost	Realized G/L Amort Cost	Sale Method
BUY											
	01/04/12	01/09/12	GENERAL ELEC CAP CORP GLOBAL NOTES	36962G5M2	1,115,000.00	(1,113,840.40)	0.00	(1,113,840.40)			
			DTD 01/09/2012 2.150% 01/09/2015								
	01/05/12	01/06/12	US TREASURY N/B	912828RV4	1,200,000.00	(1,195,312.50)	(180.33)	(1,195,492.83)			
			DTD 12/15/2011 0.250% 12/15/2014								
	01/19/12	01/19/12	FHLB NOTES	313371PC4	3,000,000.00	(3,028,170.00)	(2,697.92)	(3,030,867.92)			
			DTD 11/08/2010 0.875% 12/12/2014								
Transaction Type Sub-Total											
					5,315,000.00	(5,337,322.90)	(2,878.25)	(5,340,201.15)			
INTEREST											
	01/15/12	01/15/12	US TREASURY NOTES	912828OU7	575,000.00	0.00	1,796.88	1,796.88			
			DTD 07/15/2011 0.625% 07/15/2014								
	01/31/12	01/31/12	US TREASURY NOTES	912828PR5	2,025,000.00	0.00	6,328.13	6,328.13			
			DTD 01/31/2011 0.625% 01/31/2013								
	01/31/12	01/31/12	WELLS FARGO & COMPANY GLOBAL SR NOTES	949746NY3	1,000,000.00	0.00	21,875.00	21,875.00			
			DTD 01/31/2008 4.375% 01/31/2013								
Transaction Type Sub-Total											
					3,500,000.00	0.00	30,000.01	30,000.01			
SELL											
	01/04/12	01/09/12	GENERAL ELEC CAPITAL CORP NOTES	36962G404	1,100,000.00	1,109,416.00	6,473.96	1,115,889.96	9,922.00	9,764.56	SPEC LOT
			DTD 09/16/2010 1.875% 09/16/2013								
	01/05/12	01/06/12	US TREASURY NOTES	912828PW4	450,000.00	452,109.38	46.36	452,155.74	2,373.05	2,257.49	SPEC LOT
			DTD 12/31/2010 0.625% 12/31/2012								
	01/05/12	01/06/12	US TREASURY NOTES	912828PR5	750,000.00	753,837.89	2,025.31	755,863.20	3,457.03	3,632.80	SPEC LOT
			DTD 01/31/2011 0.625% 01/31/2013								
Transaction Type Sub-Total											
					2,300,000.00	2,315,363.27	8,545.63	2,323,908.90	15,752.08	15,654.85	



PFM Asset Management LLC



Managed Account Security Transactions & Interest

For the Month Ending January 31, 2012

CITY OF ANTIOCH, CA - 04380500

Transaction Type	Settle	Security Description	CUSIP	Par	Principal Proceeds	Accrued Interest	Total	Realized G/L Cost	Realized G/L Amort Cost	Sale Method
Managed Account Sub-Total					(3,021,959.63)	35,667.39	(2,986,292.24)	15,752.08	15,654.85	
Total Security Transactions					(\$3,021,959.63)	\$35,667.39	(\$2,986,292.24)	\$15,752.08	\$15,654.85	



PFM Asset Management LLC

**STAFF REPORT TO THE CITY COUNCIL FOR CONSIDERATION AT THE
COUNCIL MEETING OF FEBRUARY 28, 2012**

FROM: Lynn Tracy Nerland, City Attorney

DATE: February 22, 2012

SUBJECT: Rejection of Claims

RECOMMENDATION:

Reject the listed claims:

1. Thomas Moore 11/12-2049 (water bill refund)
2. Donna Humphreys 12/13-2053 (property damage)

LTN/spd

**STAFF REPORT TO THE CITY COUNCIL
FOR CONSIDERATION AT THE MEETING OF FEBRUARY 28, 2012**

Prepared by: Tina Wehrmeister, Community Development Director *TW*

Date: February 23, 2012

Subject: Adoption of the 2010 Fire Code and Adopting by Reference Ordinance No. 2010-15 of the Contra Costa County Fire Protection District with Local Findings and Amendments

RECOMMENDATION

1. Motion to read the ordinance by title only; and
2. Motion to introduce an ordinance amending Chapter 15 of Title 8 of the Antioch Municipal Code, adopting by reference Ordinance No. 2010-15 of the Contra Costa County Fire Protection District and the 2010 California Fire Code with amendments.

BACKGROUND INFORMATION

The purpose of the California Fire Code and local amendments is to prescribe regulations consistent with nationally recognized standards of safe and best practices. This purpose is accomplished by safeguarding life and property from hazards of fire, the release of hazardous materials, and hazardous conditions associated with the use or occupancy of buildings or premises.

The California Fire Code is revised and published every three years. State law allows jurisdictions to adopt local amendments to the California Fire Code pursuant to specific findings based on climatic, geographical, or topographical conditions.

The Contra Costa County Fire Protection District (CCCFFPD) provides fire protection services in the City of Antioch. Under the authority of the California Healthy and Safety Code, on December 7, 2007, the County Board of Supervisors, acting as the Board of Directors for the CCCFFPD, adopted Ordinance No. 2010-15 (Exhibit B). This ordinance amends the 2010 California Fire Code based upon findings that conclude more restrictive California Fire Code standards are necessary because of specific local climatic, geological, and topographical conditions.

Community Development and Public Works Department staff reviewed the County's ordinance and met with the Fire District representatives. Antioch staff recommends that the City Council adopt the attached ordinance which includes a minor local amendment clarifying exemptions for certain solar photovoltaic power systems.

Adopting this ordinance also allows the CCCFFPD to fully administer their weed abatement program in the City of Antioch. This is a resource that is important to the City with current reduced staffing levels.

FINANCIAL IMPACT

There are no direct financial implications associated with the recommended action.

OPTIONS

This is a state-mandated health and life-safety code therefore adoption of the ordinance is the recommended action. The Council may however, choose to further amend portions of the ordinance provided required findings can be made and the amendments are not less restrictive than the 2010 California Fire Code.

ATTACHMENTS

Proposed ordinance with the following exhibits:

Exhibit A: Findings of Need for Changes or Modifications in the 2010 California Building Standards Code, Title 24, Part 9, California Fire Code Due to Local Conditions

Exhibit B: Contra Costa County Fire Protection District Ordinance No. 2010-15

ATTACHMENT "A"

ORDINANCE NO. _____

AN ORDINANCE OF THE CITY COUNCIL OF THE CITY OF ANTIOCH AMENDING CHAPTER 15 OF TITLE 8 "FIRE CODE" OF THE ANTIOCH MUNICIPAL CODE, ADOPTING BY REFERENCE ORDINANCE NO. 2010-15 OF THE CONTRA COSTA COUNTY FIRE PROTECTION DISTRICT AND THE 2010 CALIFORNIA FIRE CODE WITH AMENDMENTS

The City Council of the City of Antioch does ordain as follows:

SECTION 1. Findings.

A. The California Building Standards Commission approved and published the 2010 edition of the California Building Standards Code, which includes the 2010 California Fire Code, on July 1, 2010 and became effective on January 1, 2011.

B. California Health and Safety Code sections 17958.7 and 18941.5(b) provide that cities and counties may make modifications or changes to the building standards contained in the California Building Standards Code "upon an express finding that such modifications or changes are reasonably necessary because of local climatic, geological, or topographical conditions."

C. The City of Antioch is within the jurisdiction of the Contra Costa County Fire Protection District.

D. The Board of Supervisors for the County of Contra Costa, acting as the Board of Directors for the Contra Costa County Fire Protection District, has adopted *Findings of Need for Changes or Modifications in the 2010 California Building Standards Code, Title 24, Part 9, California Fire Code Due to Local Conditions*, attached hereto as Exhibit A and incorporated herein by this reference, that conclude more restrictive California Fire Code standards are reasonably necessary because of specified local climatic, geological or topographical conditions.

E. Pursuant to the attached findings, the Contra Costa County Fire Protection District approved Ordinance No. 2010-15 (Exhibit B) adopting the 2010 California Fire Code and making certain amendments thereto to address local conditions.

F. The City desires to adopt that ordinance making certain additional amendments thereto to address local conditions, as set forth below.

G. Pursuant to Health and Safety Code sections 17958, 17958.5, and 17958.7, and 18941.5, the additional amendments are reasonably necessary because of the local climatic, geological, and topographical conditions set forth in Exhibit A.

SECTION 2. Chapter 15 of Title 8 of the Antioch Municipal Code is hereby amended to read in its entirety as follows:

Sec. 8-15.01. Adoption of the 2010 California Fire Code with Amendments of the Contra Costa County Fire Protection District.

The 2010 California Fire Code (California Code of Regulations, Title 24, Part, 9 [based on the 2009 International Fire Code published by the International Code Council]), including Chapters 1-45 and 47-49, Appendix Chapter 4, Appendix B, Appendix C,

Appendix D, Appendix F, Appendix H, Appendix I, and Appendix J are adopted by reference and shall be controlling and enforceable within the jurisdictional boundaries of the city.

In addition, those amendments to the California Fire Code adopted by the Contra Costa County Fire Protection District pursuant to Ordinance Number 2010-15 are adopted by reference and shall be controlling and enforceable within the jurisdictional boundaries of the city. Copies of the 2010 California Fire Code and Contra Costa Fire Protection District Ordinance 2010-15 are on file with the Community Development Department.

Sec. 8-15.02 Local Amendments to CCCFPD Ordinance No. 2010-15.

Section 105.7.21 is amended to add the following exception:

105.7.21 Solar photovoltaic power systems. A construction permit is required to install or modify solar photovoltaic power systems.

Exception: Detached Group U non-habitable structures such as parking shade structures, carports, solar trellises, similar type structures, and Group R-3 Occupancies where less than 50% of the roof area is covered with solar panels are not subject to the requirements of this section.

Sec. 8-15.03 Enforcement of the 2010 California Fire Code as Amended.

The Fire Chief of the Contra Costa County Fire Protection District or designee is authorized to enforce the Fire Code as amended within the boundaries of the city.

SECTION 3. Only Section 2 of this Ordinance shall be codified in the Antioch Municipal Code.

SECTION 4. This ordinance shall take effect and be enforced thirty (30) days from and after the date of its adoption. The ordinance or summary shall be posted and published in a newspaper of general circulation printed and published in the City of Antioch as set forth in State Law.

* * * * *

I **HEREBY CERTIFY** that the foregoing ordinance was introduced at a regular meeting of the City Council of the City of Antioch, held on the 28th day of February, 2012, and passed and adopted at a regular meeting thereof, held on the ____ day of _____, 2010.

AYES:

NOES:

ABSENT:

James D. Davis, Mayor of the City of Antioch

ATTEST:

Denise Skaggs, City Clerk of the City of Antioch

EXHIBIT A

CONTRA COSTA COUNTY FIRE PROTECTION DISTRICT FINDING OF NEED FOR CHANGES OR MODIFICATIONS IN THE 2010 CALIFORNIA BUILDING STANDARDS CODE, TITLE 24, PART 9, CALIFORNIA FIRE CODE DUE TO LOCAL CONDITIONS

I. Changes or Modifications

Pursuant to Section §17958 of the State of California Health and Safety Code, the Board of Directors of the Contra Costa County Fire Protection District, in its ordinance adopting and amending the 2010 California Building Standards Code, Title 24, Part 9, California Fire Code, changes, modifies, and amends Section 903.1 through Section 907.8.5.

II. Finding

Pursuant to Section §17958.5 and §17958.7 of the State of California Health and Safety Code, the Board of Directors of the Contra Costa County Fire Protection District finds that the above referenced change, modification, and amendment is needed and is reasonably necessary because of certain local climatic, geological, and topographic conditions as described below.

A. Climatic

1. Precipitation and Relative Humidity

(a) Conditions

Precipitation ranges from 15 to 24 inches per year with an average of approximately 20 inches per year. Ninety-six (96) percent falls during the months of October through April and four (4) percent from May through September. This is a dry period of at least five (5) months each year. Additionally, the area is subject to occasional drought. Relative humidity remains in the middle range most of the time. It ranges from forty-five (45) to sixty-five (65) percent during spring, summer, fall, and from sixty (60) to ninety (90) percent in the winter. It occasionally falls as low as fifteen (15) percent.

(b) Impact

Locally experienced dry periods cause extreme dryness of untreated wood shakes and shingles on buildings and non-irrigated grass, brush and weeds, which are often near buildings with wood roofs and sidings. Such dryness causes these materials to ignite very readily and burn rapidly and intensely.

Because of dryness, a rapidly burning grass fire or exterior building fire can quickly transfer to other buildings by means of radiation or flying brands, sparks and embers. A small fire can rapidly grow to a magnitude beyond the control capabilities of the Fire District resulting in an excessive fire loss.

2. Temperature

(a) Conditions

Temperatures have been recorded as high as 114⁰ F. Average summer highs are in the 90⁰ range, with average maximums of 105⁰ F.

(b) Impact

High temperatures cause rapid fatigue and heat exhaustion of firefighters, thereby reducing their effectiveness and ability to control large building and wildland fires.

Another impact from high temperatures is that combustible building material and non-irrigated weeds, grass and brush are preheated, thus causing these materials to ignite more readily and burn more rapidly and intensely. Additionally, the resultant higher temperature of the atmosphere surrounding the materials reduces the effectiveness of the water being applied to the burning materials. This requires that more water be applied, which in turn requires more Fire District resources in order to control a fire on a hot day. High temperatures directly contribute to the rapid growth of fires to an intensity and magnitude beyond the control capabilities of the Fire District.

3. Winds

(a) Conditions

Prevailing winds in the area are from the south or southwest in the mornings and from the north or northwest in the afternoons. However, winds are experienced from virtually every direction at one time or another. Velocities are generally in the fourteen (14) mph to twenty-three (23) mph ranges, gusting to twenty-five (25) to thirty-five (35) mph. Forty (40) mph winds are experienced occasionally and winds up to fifty-five (55) mph have been registered locally. During the winter half of the year, strong, dry, gusty winds from the north move through the area for several days creating extremely dry conditions.

(b) Impact

Winds such as those experienced locally can and do cause fires, both interior and exterior, to burn and spread rapidly. Fires involving non-irrigated weeds, grass and brush can grow to a magnitude and be fanned to intensity beyond the control capabilities of the Fire District very quickly even by relatively moderate winds. When such fires are not controlled, they can extend to nearby buildings, particularly those with untreated wood shakes or shingles.

Winds of the type experienced locally also reduce the effectiveness of exterior water streams used by the Fire District on fires involving large interior areas of buildings, fires which have vented through windows and roofs due to inadequate built-in fire protection and fires involving wood shake and shingle building exteriors. Local winds will continue to be a definite factor towards causing major fire losses to buildings not provided with fire resistive roof and siding materials and buildings with inadequately separated interior areas or lacking automatic fire protection systems. National statistics frequently cite wind conditions, such as those experienced locally, as a major factor where conflagrations have occurred.

4. Summary

These local climatic conditions affect the acceleration, intensity, and size of fire in the community. Times of little or no rainfall, of low humidity, and high temperatures create extremely hazardous conditions, particularly as they relate to wood shake and shingle roof fires and conflagrations. The winds experienced in this area can have a tremendous impact upon structure fires. During wood shake and shingle roof fires, or exposure fires, winds can carry sparks and burning brands to other structures, thus spreading the fire and causing conflagrations. In building fires, winds can literally force fires back into the building and can create a blow torch effect, in addition to preventing "natural" ventilation and cross-ventilation efforts.

B. Geological and Topographic

1. Seismicity

(a) Conditions

Contra Costa County is located in Seismic Risk Zone 4, which is the worst earthquake area in the United States. Buildings and other structures in Zone 4 can experience major seismic damage. Contra Costa County is in close proximity to the San Andreas Fault and contains all or portions of the Hayward, Calaveras, Concord, Antioch, Mt. Diablo, and other lesser faults. A 4.1 earthquake with its epicenter in Concord occurred in 1958, and a 5.4 earthquake with its epicenter also in Concord occurred in 1955. The Concord and Antioch faults have a potential for a Richter 6 earthquake and the Hayward and Calaveras faults have the potential for a Richter 7 earthquake. Minor tremblers from seismic activity are not uncommon in the area.

The fire environment of a community is primarily a combination of two factors: the area's physical **geologic** characteristics and a historic pattern of urban-suburban development. These two factors, alone and combined, create a mixture of environments which ultimately determines the area's fire protection needs. The Fire District has 3 distinct areas. They are: the West, which includes the City of San Pablo and the communities of North Richmond, El Sobrante, and East Richmond Heights. The Central includes the Cities of Lafayette, Martinez, Pleasant Hill, Concord, Walnut Creek, Clayton and the communities of Clyde, Pacheco, Alhambra Valley and Alamo. The East includes the Cities of Antioch, Pittsburg and the community of Bay Point.

Because of the size of the Contra Costa County Fire Protection District (304 Square miles) the characteristics of the fire environment changes from one location to the next. Therefore the District has not one, but a number of fire environments, each of which has its individual fire protection needs from two major oil refineries, to heavy industrial facilities, freeways, rail lines, waterways, port facilities, wildland areas, urban and suburban town settings and major downtown areas.

Interstates 80 and 680, State Highways 4, 24 and 242, Bay Area Rapid Transit District (BART) and major thoroughfares travel throughout the District. There are 2 major rail lines which run through the District. An overpass or underpass crossing collapse would alter the response route and time for responding emergency equipment. This is due to the limited crossings of the major highways and rail lines.

Earthquakes of the magnitude experienced locally can cause major damage to electrical transmission facilities, which, in turn, cause power failures while at the same time starting fires throughout the Fire District. The occurrence of multiple fires will quickly deplete existing fire district resources; thereby reducing and/or delaying their response to any given fire. Additionally, without electrical power, elevators, smoke management systems, lighting systems, alarm systems and other electrical equipment urgently needed for building evacuation and fire control in large buildings without emergency generator systems would be inoperative, thereby resulting in loss of life and/or major fire losses in such buildings.

(b) Impact

A major earthquake could severely restrict the response of the Fire District and its capability to control fires involving buildings of wood frame construction, with ordinary wood shake and shingle exteriors, or with large interior areas not provided with automatic smoke and fire control systems.

2. Soils

(a) Conditions

The area is replete with various soils, which are unstable, clay loam and alluvial fans being predominant. These soil conditions are moderately to severely prone to swelling and shrinking, are plastic, and tend to liquefy.

Throughout the Fire District, the topography and development growth has created a network of older, narrow roads. These roads vary from gravel to asphalt surface and vary in percent of slope, many exceeding twenty- (20) percent. Several of these roads extend up through the winding passageways in the hills providing access to remote, affluent housing subdivisions. Many of these roads are private with no established maintenance program. During inclement weather, these roads are subject to rock and mudslides, as well as down trees, obstructing all vehicle traffic. It is anticipated that during an earthquake, several of these roads would be practically impassable.

3. Topographic

(a) Conditions

i. Vegetation

The service area of the Contra Costa County Fire Protection District has a varied topography and vegetative cover. A conglomeration of flat lands, hills, and ridges make up the terrain. Development has occurred on the flat lands in the

District and in the past 15 years development has spread into the hills, valleys and ridge lands of the District.

Highly combustible dry grass, weeds, and brush are common in the hilly and open space areas adjacent to built-up locations six (6) to eight (8) months of each year. Many of these areas frequently experience wildland fires, which threaten nearby buildings, particularly those with wood roofs, or sidings. This condition can be found throughout the Fire District, especially in those fully developed areas and those areas marked for future development.

ii. Surface Features

The arrangement and location of natural and manmade surface features, including hills, creeks, canals, freeways, housing tracts, commercial development, fire stations, streets and roads, combine to limit efficient response routes for Fire District resources into and through many areas.

iii. Buildings, Landscaping and Terrain

Many of the "newer" large buildings and building complexes have access and landscaping features or designs which preclude, or greatly limit, efficient approach or operational access to them by Fire District vehicles. In addition, the presence of security gates, roads of inadequate width and grades which are too steep for Fire District vehicles create an adverse impact on fire suppression efforts.

When Fire District vehicles cannot gain access to buildings involved with fire, the potential for complete loss is realized. Difficulty reaching a fire site often requires additional fire personnel and resources to successfully and safely mitigate the event. Access problems often result in severely delaying, misdirecting, or making fire and smoke control efforts unsuccessful.

(b) Impact

The above local geological and topographical conditions increase the magnitude, exposure, accessibility problems, and fire hazards presented to the Contra Costa County Fire Protection District. Fire following an earthquake has the potential of causing greater loss of life and damage than the earthquake itself. Hazardous materials, particularly toxic gases, could pose the greatest threat to the largest number, should a significant seismic event occur. Public Safety resources would have to be prioritized to mitigate the greatest threat, and may likely be unavailable for smaller single dwelling or structure fires.

Other variables may intensify the situation:

1. The extent of damage to the water system.
2. The extents of isolation due to bridge and/or freeway overpass collapse.
3. The extent of roadway damage and/or amount of debris blocking the roadways.
4. Climatic conditions (hot, dry weather with high winds).
5. Time of day will influence the amount of traffic on roadways and could intensify the risk to life during normal business hours.

6. The availability of timely mutual aid or military assistance.
7. The large portion of dwellings with wood shake or shingles coverings could result in conflagrations.

III. Summary

Local climatic, geologic, and topographic conditions impact fire prevention efforts, and the frequency, spread, acceleration, intensity, and size of fire involving buildings in this community. Further, they impact potential damage to all structures from earthquake and subsequent fire. This was the case in the October 17, 1989 Loma Prieta earthquake that measured 6.9 and occurred on the San Andreas fault, centered near Santa Cruz. This event caused several residential fires and numerous commercial buildings were damaged.

Therefore, based on the findings declared in this document, it is found reasonably necessary that the 2010 California Fire Code be changed or modified to mitigate the effects of the above conditions.

The changes and/or modifications to the 2010 California Fire Code, as expressed in Contra Costa County Fire Protection District Ordinance #2010-15, are found to be necessary to mitigate the above described impacts which are caused by the above described local climatic, geological and topographic conditions.

Ordinance #2010-15 is attached in its entirety.

EXHIBIT B

ORDINANCE NO. 2010-15

FIRE CODE

ORDINANCES OF THE COUNTY OF CONTRA COSTA, THE CROCKETT-CARQUINEZ FIRE PROTECTION DISTRICT, AND THE CONTRA COSTA COUNTY FIRE PROTECTION DISTRICT ADOPTING THE 2010 CALIFORNIA FIRE CODE WITH AMENDMENTS.

The Contra Costa County Board of Supervisors, as the Board of Supervisors for Contra Costa County and as the Board of Directors of the Crockett-Carquinez Fire Protection District and the Contra Costa County Fire Protection District, ordains as follows:

SECTION 1. ADOPTION OF THE CALIFORNIA FIRE CODE.

Contra Costa County, the Crockett-Carquinez Fire Protection District and the Contra Costa County Fire Protection District hereby adopt the 2010 California Fire Code (California Code of Regulations, Title 24, Part 9 [based on the 2009 International Fire Code published by the International Code Council]), including Chapters 1-45 and 47-49, Appendix Chapter 4, Appendix B, Appendix C, Appendix D, Appendix F, Appendix H, Appendix I, and Appendix J, as amended by the changes, additions and deletions set forth in this ordinance. The 2010 California Fire Code, with the changes, additions, and deletions set forth in this ordinance, is adopted by this reference as though fully set forth in this ordinance. As of the effective date of this ordinance, the provisions of the fire code are controlling and enforceable within the limits of each jurisdiction.

SECTION 2. AMENDMENTS TO THE CALIFORNIA FIRE CODE.

The 2010 California Fire Code is amended by the changes, additions and deletions set forth in this Section 2. Chapter and Section numbers used below are those of the 2010 California Fire Code.

Chapter 1. Administration.

Section 101.1 is amended to read:

101.1 Title. This code is the Fire Code of Contra Costa County, the Crockett-Carquinez Fire Protection District, and the Contra Costa County Fire Protection District, and is hereinafter referred to as "this code".

Section 102.1 is amended to add item 5, to read:

102.1 Construction and design provisions. The construction and design provisions of this code shall apply to:

5. Where not otherwise limited by law, the provisions of this code shall apply to vehicles, ships, and boats that are permanently affixed to a specific location within the boundaries of this jurisdiction.

ORDINANCE NO. 2010-15

Section 105.6 is amended to read:

105.6 Required operational permits. The fire code official is authorized to issue operational permits for the operations set forth in Chapter 1, Sections 105.6.1 through 105.6.54.

Section 105.6 is amended by adding subsections 105.6.48 through 105.6.54, to read:

105.6.48 Asbestos removal. A permit is required to conduct asbestos-removal operations regulated by Section 1418.

105.6.49 Battery systems. A permit is required to operate stationary lead-acid battery systems having a liquid capacity of more than 50 gallons (189 L) pursuant to Section 608.

105.6.50 Christmas tree sales. A permit is required to use a property for the purpose of selling cut Christmas trees.

105.6.51 Firework aerial display. A permit is required to conduct a firework display regulated by California Code of Regulations, Title 19 and Chapter 33 of this code.

105.6.52 Model rockets. A permit is required to sell or launch model rockets pursuant to California Code of Regulations, Title 19, Division 1, Article 17.

105.6.53 Temporary water supply. A permit is required to use a temporary water supply for construction of residential projects or subdivisions pursuant to Section 1412.1.

105.6.54 Tire storage. A permit is required to store more than 1,000 cubic feet (28.3m³) of tires inside buildings pursuant to Chapter 25.

Section 105.7 is amended to read:

105.7 Required construction permits. The fire code official is authorized to issue construction permits for the operations set forth in Chapter 1, Sections 105.7.1 through 105.7.21.

Section 105.7 is amended by adding sections 105.7.15 through 105.7.21 as follows:

105.7.15 Access for fire apparatus. Plans shall be submitted and a permit is required to install, improve, modify, or remove public or private roadways, driveways, and bridges for which Fire District access is required by the Fire Code. A permit is required to install a gate across a fire apparatus access road pursuant to Section 503.

105.7.16 Construction, alteration, or renovation of a building for which a building permit is required. Plans shall be submitted to the fire code official for all land developments or for the construction, alteration, or renovation of a building within the jurisdiction where a building permit is required.

Exception: Non-sprinklered Group R-3 Occupancies where work does not involve a substantial addition or expansion.

105.7.17 Medical gas systems. A construction permit is required for the installation of or modification to a medical gas system pursuant to Section 3006.

105.7.18 Refrigeration equipment. A permit is required to install a mechanical refrigeration unit or system regulated by Chapter 6.

105.7.19 Land Development, Subdivisions. Plans shall be submitted to the fire code official for all land developments or improvements proposed within the jurisdiction that involve the subdivision of land.

105.7.20 Water supply for fire protection. Plans shall be submitted to the fire code official for the purpose of determining whether adequate water supplies, fire hydrants, and associated systems are provided for all facilities, buildings or portions of buildings either constructed or moved into the District pursuant to Section 507.

105.7.21 Solar photovoltaic power systems. A construction permit is required to install or modify Solar photovoltaic power systems.

Section 108.1 is amended to read:

108.1 Board of Appeals established. In order to hear and decide appeals of orders, decisions or determinations made by the fire code official relative to the application and interpretation of this code, there is hereby created a board of appeals. The board of appeals is comprised of the Board of Directors.

Section 108.3 is deleted.

Section 109.3 is amended in its entirety to read:

109.3 Violation penalties. Every person who violates any provision of this fire code is guilty of a misdemeanor. The imposition of one penalty for any violation shall not excuse the violation or permit it to continue; and all such persons shall be required to correct or remedy such violations or defects within a reasonable time; and when not otherwise specified, each ten (10) days that prohibited conditions are maintained shall constitute a separate offense. The application of the aforesaid penalty shall not be held to prevent the enforced removal of prohibited conditions. This section is a declaration of Health and Safety Code section 13871 and is not intended to create a different or separate penalty.

Section 111.4 is amended to read:

111.4 Failure to comply. Any person who continues any work after having been served with a stop work order is subject to citation, except any work that a person is directed by the fire code official to perform to remove a violation or unsafe condition.

Chapter 2. Definitions

Section 202 is amended by adding the following definitions to read:

Administrator. Fire Chief.

All-weather driving surface. A roadway with a minimum surface finish of one layer of asphalt or concrete that is designed to carry the imposed weight loads of fire apparatus.

Board of Directors. The Contra Costa County Board of Supervisors as the governing body of the Crockett-Carquinez Fire Protection District and the Contra Costa County Fire Protection District.

Board of Fire Commissioners. An advisory commission appointed by the Board of Directors to act as set forth in this ordinance and by resolutions of the Board of Directors.

Driveway. A private roadway that provides access to no more than two (2) single-family dwellings.

Fire Code Official. In the Contra Costa County Fire Protection District, the Fire Code Official is the Fire Marshal. In the Crockett-Carquinez Fire Protection District, the Fire Code Official is the Fire Chief.

Firebreak. A continuous strip of land upon and from which all rubbish, weeds, grass or other growth that could be expected to burn has been abated or otherwise removed in order to prevent extension of fire from one area to another.

Firetrail. A graded firebreak of sufficient width, surface, and design to provide access for personnel and equipment to suppress and to assist in preventing a surface extension of fires.

Nuisance Fire Alarm. The activation of any fire protection or alarm system which results in the response of the Fire District and is caused by malfunction, improper maintenance, negligence, or misuse, of the system by an owner, occupant, employee, or agent, or any other activation not caused by excessive heat, smoke, fire, or similar activating event.

Response time. The elapsed time from receipt of call to the arrival of the first unit on scene.

Rural area. An area generally designated for agricultural or open space uses with parcels more than 10 acres (4.046873ha) in size.

Rural residential area. An area generally designated for single family residential use with parcels between three (1.2140619ha) and 10 (4.046873ha) acres in size.

Running time. The calculated time difference between leaving the first-due station and arriving on the emergency scene.

Sprinkler Alarm and Supervisory System (SASS): A Dedicated Function Fire Alarm System located at the protected premise installed specifically to monitor sprinkler water-flow alarm, valve supervisory, and general trouble conditions where a Building Fire Alarm is not required.

Substantial Addition or Expansion. Addition, expansion, remodel, or renovation of any structure where the addition of new fire area exceeds fifty percent of the existing fire area.

Temporary fire department access road for construction. An approved temporary roadway for emergency vehicle use during construction of residential subdivision projects.

Temporary fire department access road for construction of one (1) residential (R3) unit. A temporary roadway for emergency vehicle use during construction of an individual residential (R3) structure where a fire department access road is required as part of the project.

Temporary water supply. Water stored for firefighting purposes in an approved aboveground tank during combustible construction.

Tree litter. Any limbs, bark, branches and/or leaves in contact with other vegetation or left to gather on the ground.

Chapter 3. General Precautions Against Fire.

Section 304.1.2 is amended to read:

304.1.2 Vegetation. Hazards created by the growth of weeds, grass, vines, trees or other growth capable of being ignited and endangering property shall be mitigated in accordance with Section 318.

Section 304.1.4 is added to read:

304.1.4 Clothes Dryers. Clothes dryers shall be frequently cleaned to maintain the lint trap, mechanical and heating components, vent duct and associated equipment free from accumulations of lint and combustible materials.

Section 308.1.4 Exception 1 is amended to read:

Exception 1. Residential Occupancies.

Section 318 is added to Chapter 3, to read:

318 Exterior Fire Hazard Control.

318.1 General.

318.1.1 Jurisdictional Authority. The Board of Directors, as the supervising, legislative and executive authority of the jurisdiction, hereby delegates to the Board of Fire Commissioners of the jurisdiction all its powers, duties and rights to act pursuant to Part 5 (commencing with Section 14875), Division 12, of the Health and Safety Code, to clear or order the clearing of rubbish, litter or other flammable material where such flammable material endangers the public the safety by creating a fire hazard. Fire hazard abatement will be conducted in accordance with the provisions of said Part 5 and this ordinance. In the application of the provisions of said Part 5 to fire hazard abatement proceedings under this ordinance and the Fire Protection District Law of 1987, the terms "Board of Directors" or "Board," when used in Part 5, means the Board of Fire Commissioners of this jurisdiction under this section; and the officers designated in Health and Safety Code Section 14890 are the employees of the jurisdiction.

318.1.2 Retention of Jurisdictional Authority. If no Board of Fire Commissioners has been appointed for the jurisdiction, then the Board of Directors retains its powers and rights to act pursuant to said Part 5.

318.1.3 Contract for Services. The Board of Directors reserves and retains the power to award a contract for fire hazard abatement work when the employees of the jurisdiction are not used to perform the abatement work.

318.2 Definitions.

Weeds. All weeds growing upon streets or private property in the jurisdiction, including any of the following:

1. Weeds that bear seeds of a fluffy nature or are subject to flight.
2. Sagebrush, chaparral (including Chamise, Coyote Brush/Greasewood, Brooms, and Buckwheat), and any other brush or weeds that attain such large growth as to become, when dry, a fire menace to adjacent improved property.
3. Weeds that are otherwise noxious or dangerous.
4. Poison oak and poison sumac when the conditions of growth constitute a menace to public health.
5. Dry grass, brush, tree litter, litter, or other flammable materials that endanger the public safety by creating a fire hazard.

Rubbish. Waste matter, litter, trash, refuse, debris and dirt on streets, or private property in the jurisdiction which is, or when dry may become, a fire hazard.

Streets. Includes alleys, parkways, driveways, sidewalks, and areas between sidewalks and curbs, highways, public right of ways, private road, trails, easements, and fire trails.

Person. Includes individuals, firms, partnerships, and corporations.

Defensible Space. The area within the perimeter of a parcel providing the key point of defense from an approaching wildland or escaping structure fire.

Priority Hazard Zone. An area where the threat from wildfire is severe due to proximity to open space, topography, degree of space, density of homes amount of vegetation (native and ornamental) and other conditions favorable to fast moving fires.

Reduced Fuel Zone. The area that extends from thirty (30) feet to one hundred (100) feet or more away from the structure or to the property line, whichever is closer to the structure.

Cost of Abatement. Includes all expenses incurred by the jurisdiction in its work of abatement undertaken and administrative costs pursuant to Section 318.5 of this Ordinance.

318.3 Weeds and Rubbish a Public Nuisance. The Board hereby declares that all weeds growing upon private property or streets in this jurisdiction and all rubbish on private property or streets in this jurisdiction are public nuisances. Such weed nuisance is seasonal and recurrent.

318.4 Abatement of Hazard.

318.4.1 Prohibition. No person who has any ownership or possessory interest in or control of parcel of land shall allow to exist thereon any hazardous rubbish, weeds, trees, or other vegetation that constitutes a fire hazard. Destruction by burning within this jurisdiction is unlawful unless the written permission of the fire chief is first obtained, and all other applicable permits are obtained from appropriate governing agencies or jurisdictions.

318.4.2 Specific Requirements. The District shall develop minimum abatement standards for land in residential, rural and/or rural residential, business, industrial areas, or land which is unused or vacant. Such standards may be modified periodically as circumstances dictate.

318.4.2.1 Clearance of Weeds from Streets. The Fire Code Official is authorized to cause areas within 10 feet (3048 mm) on each side of portions of streets which are improved, designed or ordinarily used for vehicular traffic to be cleared of flammable vegetation and other combustible growth. The Fire Code Official is authorized to enter upon private property to do so, to the extent allowed by law.

318.5 Abatement Procedures.

318.5.1 Abatement Order. The fire code official may order the abatement of the weeds and rubbish described in Sections 304.1.2 and 318.2. On making the order, the fire code official will mail a copy of a notice to the owners of the affected property as their names and addresses appear upon the last county equalized assessment roll, or as their names and addresses are known to the fire code official. As an alternative to mailing, the notice may be posted upon the affected property and published in the jurisdiction, not less than 15 days prior to the date of the abatement hearing. Copies of the notice will be headed with the words "Notice to Abate Weeds and Rubbish" in letters at least one inch high. The notice will be in substantially the following form:

NOTICE TO ABATE WEEDS AND RUBBISH

You are hereby notified that weeds and rubbish constitute a fire hazard on the following described property owned by you:

(Describe property by common street designation, by metes and bounds, Assessor's code area and parcel number, or by reference to attached map).

You must remove the weeds and rubbish within fifteen (15) days from the date of this notice. If you fail to do so, the (jurisdiction) Fire Protection District will remove it, and the cost of the abatement, including administrative costs, will be collected as property taxes and will be a lien on your property until paid.

You are further notified that the Board of Supervisors has declared that such weeds and rubbish constitute a public nuisance and that such weeds also constitute a seasonal and recurring nuisance.

You may appear before the Board of Fire Commissioners of this jurisdiction on (time and date) at (place-room, street, address, and city) to show cause why this order should not be enforced.

(Signed): (Name of fire code official of name of jurisdiction)

318.5.2 Hearing Date. A date for hearing on the notice will be sent at least 15 days after the date of the notice. The date of the notice is the date on which the notice is placed in the United States mail or the date on which it is posted on the property. At the hearing, the property owner or his agent may appear to show cause why the order should not be enforced. For good cause shown, the Board of Fire Commissioners may extend the time for compliance with the order or may rescind the order.

318.5.3 Contract Award. If the owner fails to comply with the order, the fire code official may have the weeds and rubbish abated either by employees of this jurisdiction or by contract. If a contract is awarded, it will be by public bid, awarded to the lowest responsible bidder. A contract may include work on more than one parcel. Concerning any contract previously awarded as provided in this subsection and that has been fully extended as provided in that contract, it may thereafter be extended on its same terms and conditions for a further period (not to exceed one year) by agreement of the Board of Supervisors and the involved contractor.

318.5.4 Abatement Report of Costs. The fire code official or his or her designee abating the nuisance will keep an account of the cost of abatement in front of or on each separate parcel of land and will render an itemized report in writing to the Board of Fire Commissioners showing the cost of removing the weeds and rubbish on or in front of each separate lot or parcel of land, or both. Before the report is submitted to the Board of Fire Commissioners, a copy of it will be posted for at least three days on or near the chamber door of the Board with a notice of the time and when the report will be submitted to the Board for confirmation. At the time fixed for receiving and considering the report, the Board of Fire Commissioners will hear it and any objections of any of the property owners liable to be assessed for the work of abatement. Thereupon, the Board of Fire Commissioners may make such modifications in the report as it deems necessary, after which the report will be confirmed. The amount of the cost, including administrative costs, of abating the nuisance in front of or upon the various parcels of the land mentioned in the report as confirmed will constitute special assessment against the respective parcels of land, and are a lien on the property for the amount of the respective assessments. Such lien attaches upon recordation, in the office of the County Recorder, of a certified copy of the Resolution of Confirmation.

318.5.5 Cost Assessments. Upon confirmation of the report of cost by the Board of Fire Commissioners and the recordation of the Resolution of Confirmation, a copy of the report of cost will be sent to the County Auditor, who will enter the amount of the assessments against the parcels. Thereafter the amount of the assessments will be collected at the same time and in the same way as County taxes are collected. The owners are subject to the same penalties and the same procedure and sale in case of delinquency as provided for ordinary county taxes. All laws applicable to the levy, collection, and enforcement of county taxes are applicable to these assessment taxes.

318.6 Alternate Mitigation. In lieu of ordering abatement as provided in Section 318.5.1, the fire code official of this jurisdiction may order the preparation of firebreaks/fuelbreaks around parcels of property where combustible weeds, crops, or brush are present. In determining the proper width for firebreaks/fuelbreaks, the fire code official will consider the height of the growth, weather condition, topography, and the accessibility to the property for fire protection equipment. The procedure set forth in Section 318.5.1 for the abatement of weeds and rubbish shall apply to the preparation of firebreaks/fuelbreaks.

318.7 Subsurface Fires.

318.7.1 Peat Fire. It is the duty of each person, firm, corporation, or association not to permit a peat fire in or a fire involving combustible vegetable matters under the surface of the natural ground to remain upon the property. It is hereby declared that it is the duty of any person as herein defined to take all necessary precautions to extinguish any subsurface fire involving peat or vegetable material at the owner's own cost and expense.

318.7.2 Fire Suppression Costs. If there exists upon the lands or property of any person as herein defined a subsurface fire involving the burning or combustion of peat, vegetable matter or vegetation, and the owner or occupant thereof has not taken reasonable precautions within a reasonable time to extinguish or minimize such fire or combustion, this jurisdiction may, in addition to its regular duties to extinguish or minimize such fire or combustion, go upon the lands of any person as herein defined and extinguish such fire or combustion. Any costs incurred by the Fire District in fighting the fire and for the cost of proving rescue or emergency medical services shall be a charge against the property owner. The charge shall constitute a debt of the property owner and is collectable by the jurisdiction incurring those costs in the same manner as in the case of an obligation under a contract, express or implied. (See Health and Safety Code, §13009.)

Section 319 is added to Chapter 3 to read:

319 Automobile Wrecking Yards.

319.1 General. The operation of automobile wrecking yards shall be in accordance with this section.

319.2 Definitions.

Automobile Wrecking Yard. An area that stores or dismantles salvaged vehicles.

Automobile Dismantling. The operation of dismantling or removing parts from salvaged vehicles including engines or engine parts.

319.3 Requirements.

319.3.1 Permits. An operation permit is required for all automobile wrecking yards, automobile dismantling operations, and similar operations.

319.3.2 Fire Apparatus Access Roads. Fire apparatus access roads shall be constructed throughout the site in accordance with this code and shall be maintained clear of all vehicles and stored items.

319.3.3 Welding and cutting. Welding and cutting operations shall be conducted in an approved location, clear of all flammable liquids and combustible materials, including weeds, tires and all other debris.

319.3.4 Housekeeping. Combustible rubbish accumulated on site shall be collected and stored in approved containers, rooms or vaults of noncombustible materials. Combustible vegetation, cut or uncut, shall be removed when determined by the fire code official to be a fire hazard.

319.3.5 Fire Protection. Offices, storage buildings and vehicles used for site operations shall each be provided with at least one portable fire extinguisher with not less than a 4-A: 40-B-C rating. When required by the fire code official, additional fire extinguishers shall be provided.

319.3.6 Tire storage. Tires shall be stored in racks or in a manner as approved by the fire code official.

319.3.6.1 Distance from Water Supply. Tire storage shall be located on-site and no further than 500 feet from a fire hydrant or an approved water supply as determined by the fire code official.

319.3.7 Storage Piles. Storage piles shall be located a minimum of 20 feet from property lines and shall have an unobstructed access road on all sides of not less than 20 feet.

319.3.8 Burning operations. The burning of salvaged vehicles and salvaged or waste materials is prohibited.

319.3.9 Motor vehicle fluids. Motor vehicle fluid shall be drained from salvaged vehicles when such liquids are leaking onto the ground and prior to dismantling or removing engine/motor parts.

319.3.9.1 Mitigation of leaking fluids. Precautions shall be taken to prevent fluids from salvaged vehicles from leaking onto the ground. Supplies or equipment capable of mitigating leaks from fuel tanks, crankcases, brake systems and transmissions shall be kept available on site. Single-use plugs, diking and absorbent materials shall be disposed of as hazardous waste and removed from the site in a manner in accordance with federal, state and local requirements.

319.3.10 Fuel tanks. Fuel tanks of salvaged vehicles shall be emptied of all flammable (gasoline, diesel) fuels in an approved manner and stored in approved tanks.

319.3.10.1 Repair of vehicle fuel tanks. The repair of fuel tanks, including cutting, welding or drilling of any kind, is prohibited.

319.3.11 Lead acid batteries. Lead acid batteries shall be removed from all salvaged vehicles and stored in an approved manner in a location approved by the fire code official.

Chapter 4. Emergency Planning and Preparedness.

Section 401.3.1 is amended by adding a new subsection 401.3.1.1 to read:

401.3.1.1 Nuisance Fire Alarm fee. A fee may be charged for false and/or nuisance fire alarms in accordance with a fee schedule adopted by the Board of Directors.

Chapter 5. Fire Service Features.

Section 503.1 is amended to add subsection 503.1.4 to read:

503.1.4 Access to Open Spaces. When existing access to open land or space, or to fire trail systems maintained for public or private use, is obstructed by new development of any kind, the developer shall

provide an alternate means of access into the area that is sufficient to allow access for fire personnel and apparatus. The alternate means of access must be approved by the fire code official.

Section 503.2.1 is amended by adding the following exception:

Exception: A minimum 16 foot wide driveway is acceptable for access to one or two single-family dwellings.

Section 505 is amended by adding Section 505.3, to read:

505.3 Street names and addressing. Street names and addressing shall be submitted for review and approval to the fire code official, whose approval will not be unreasonably withheld. The purpose of the review is to verify that new street names and addressing will not duplicate existing street names and addressing.

Section 507.2 is amended by adding subsection 507.2.3, to read:

507.2.3 Suburban and rural water supply storage. Swimming pools and ponds shall not be considered water storage for the purposes of Section 507.1.

Section 510.1.1 is added to read:

Section 510.1.1 Emergency Responder Radio Installation. Installations of emergency responder radios shall be in accordance with Appendix J of this code.

Chapter 6. Building Services and Systems.

Section 603.6 is amended by adding subsection 603.6.6, to read:

603.6.6 Sparks from chimneys. A chimney that is used with either a fireplace or heating appliances in which solid or liquid fuel is used shall be maintained with spark arresters that are required for incinerators pursuant to the California Mechanical Code.

Section 605.11 is added to Chapter 6 to read:

605.11 Solar Photovoltaic Power Systems. Solar photovoltaic power systems shall be installed in accordance with this code, the California Building Code and California Electrical Code.

Exception: Detached Group U non-habitable structures such as parking shade structures, carports, solar trellises, similar type structures, and Group R-3 Occupancies where less than 50% of the roof area is covered with solar panels are not subject to the requirements of this section.

605.11.1 Marking. Marking is required on all interior and exterior DC conduit, enclosures, raceways, cable assemblies, junction boxes, combiner boxes, and disconnects.

605.11.1.1 Materials. The materials used for marking shall be reflective, weather resistant and suitable for the environment. Marking as required in sections 605.11.1.2 through 605.11.1.4 shall have all letters capitalized with a minimum height of 3/8 inch (9.5 mm) white on red background.

605.11.1.2 Marking content. The marking shall contain the words "WARNING: PHOTOVOLTAIC POWER SOURCE"

605.11.1.3 Main service disconnect. The marking shall be placed adjacent to the main service disconnect in a location clearly visible from the location where the disconnect is operated.

605.11.1.4 Location of Marking. Marking shall be placed on all interior and exterior DC conduit, raceways, enclosures and cable assemblies every 10 feet (3048 mm) within 1 foot (305 mm) of all turns or bends and within 1 foot (305 mm) above and below all penetrations of roof/ceiling assemblies and all walls and/or barriers.

605.11.2 Locations of DC conductors. Conduit, wiring systems, and raceways for photovoltaic circuits shall be located as close as possible to the ridge or hip or valley and from the hip or valley as directly as possible to an outside wall to reduce trip hazards and maximize ventilation opportunities. Conduit runs between sub arrays and to DC combiner boxes shall be installed in a manner that minimizes total amount of conduit on the roof by taking the shortest path from the array to the DC combiner box. The DC combiner boxes shall be located such that conduit runs are minimized in the pathways between arrays. DC wiring shall be installed in metallic conduit or raceways when located within enclosed spaces in a building. Conduit shall run along the bottom of load bearing members.

605.11.3 Access and pathways. When a solar photovoltaic power system installed on a roof, roof access, pathways, and spacing requirements shall be provided in order to ensure access to the roof; provide pathways to specific areas of the roof; provide for smoke ventilation operations; and to provide emergency egress from the roof.

Exceptions:

1. Requirements relating to ridge, hip, and valleys do not apply to roofs with slopes with a ratio of two units vertical to twelve units horizontal (2:12) or less.
2. Residential structures shall be designed so that each array is no greater than 150 feet (45 720 mm) by 150 feet (45 720 mm) in either axis.
3. The fire chief may allow panels/modules to be located up to the ridge when an alternative ventilation method acceptable to the fire chief has been provided or where the fire chief has determined vertical ventilation techniques will not be employed.

605.11.3.1 Roof access. When a solar photovoltaic power system is installed on a roof, roof access must be provided in an area that does not place ground ladders over openings such as windows or doors, and at strong points of building construction in locations where the access point does not conflict with overhead obstructions such as tree limbs, wires, or signs.

605.11.3.2 Residential systems for one- and two-family residential dwellings. A solar photovoltaic power system installed on the roof of a one- or two-family residential dwelling shall be installed in accordance with Sections 605.11.3.2.1 through 605.11.3.2.4

605.11.3.2.1 Residential buildings with hip roof layouts. Panels /modules shall be located in a manner that provides a 3 foot (914 mm) wide clear access pathway from the eave to the ridge on each roof slope where panels/modules are located. The access pathway shall be located at a structurally strong location on the building capable of supporting the live load of fire fighters accessing the roof.

605.11.3.2.2 Residential buildings with a single ridge. Panels/modules shall be located in a manner that provides two three-foot (3') wide access pathways from the eave to the ridge on each roof slope where panels/modules are located.

605.11.3.2.3 Hips and Valleys. Panels/modules shall be located no closer than 18 inches (457 mm) to a hip or valley if panels/modules are to be placed on both sides of a hip or valley. If the panels are to be located on only one side of a hip or valley that is of equal length then the panels may be placed directly adjacent to the hip or valley.

605.11.3.2.4 Smoke Ventilation. Panels/modules shall be located no higher than 3 feet (914 mm) below the ridge in order to allow for fire department smoke ventilation operations.

605.11.3.3 All other occupancies. A solar photovoltaic power system installed on the roof of any occupancy other than a one- or two-family residential dwelling shall be installed in accordance with 605.11.3.3.1 through 605.11.3.3.3.

Exception: Where it is determined by the fire code official that the roof configuration is similar to a one- or two-family dwelling, the fire code official may approve the residential access and ventilation requirements provided in 605.11.3.2.1 through 605.11.3.2.4.

605.11.3.3.1 Access. There shall be a minimum 6 foot (1829 mm) wide clear perimeter around the edges of the roof.

Exception: If either axis of the building is 250 feet (76 200 mm) or less, there shall be a minimum four 4 foot (1290 mm) wide clear perimeter around the edges of the roof.

605.11.3.3.2 Pathways. The solar installation shall be designed to provide designated pathways. The pathways shall meet the following requirements:

1. The pathway shall be over areas capable of supporting the live load of fire fighters accessing the roof
2. The center line axis pathways shall be provided in both axes of the roof. Center line axis pathways shall run where the roof structure is capable of supporting the live load of firefighters accessing the roof.
3. There shall be a straight pathway, at least four feet (1290 mm) wide, clear to each skylight and/or ventilation hatch.
4. There shall be a straight pathway, at least four feet (1290 mm) wide, clear to each roof standpipe.
5. There shall be a straight pathway, at least four feet (1290 mm) wide, around each roof access hatch, with at least one pathway at least four feet (1290 mm) wide, clear to each parapet or roof edge.

605.11.3.3.3 Smoke Ventilation. The solar installation shall be designed to meet the following requirements:

1. Arrays shall be no greater than 150 feet (45 720 mm) by 150 feet (45 720 mm) in distance in either axis in order to create opportunities for smoke ventilation operations.
2. Smoke ventilation options between array sections shall be one of the following:
 - 2.1. A pathway 8 feet (2438 mm) or greater in width;
 - 2.2. A 4 foot (1290 mm) or greater in width pathway and bordering roof skylights or smoke and heat vents;
 - 2.3. A 4 foot (1290 mm) or greater in width pathway and bordering 4 foot (1290 mm) x 8 foot (2438 mm) "venting cutouts" every 20 feet (6096 mm) on alternating sides of the pathway

605.11.4 Ground mounted photovoltaic arrays. Ground mounted photovoltaic arrays shall be installed to comply with Sections 605.11 through 605.11.2 and this section. Access and pathway requirements do not apply to ground-mounted, free standing photovoltaic arrays. A clear brush area of 10 feet (3048 mm) is required for ground mounted photovoltaic arrays.

Chapter 8. Interior Finish, Decorative Materials and Furnishings.

Section 806 is amended by adding subsections 806.1.4, 806.1.5 and 806.1.6, to read:

806.1.4 Flame retardants. Cut trees shall be treated by a California State Fire Marshal-licensed fire retardant applicator. Trees shall be properly treated with an approved flame retardant.

806.1.5 Tags. Trees shall bear a tag stating date of placement in the public building, type of flame-retardant treatment used, name of the person who applied the flame retardant, the name of the person affixing the tag, a permit expiration date and the name of the designated individual making daily tests.

806.1.6 Daily tests. Trees shall be tested daily by a designated individual. The test shall include a check for dryness and adequate watering.

Chapter 9. Fire Protection Systems.

Section 901.6.2.2 is added to read:

901.6.2.2 Inspection Records. Records of all inspections, testing and maintenance for all water based fire suppression systems shall be completed on the forms found in annex B of NFPA 25, California Edition.

Section 902 is amended to add:

Substantial Addition or Expansion. Addition, expansion, remodel, or renovation of any structure where the addition of new fire area exceeds fifty percent of the existing fire area.

Section 903.2 is adopted in its entirety except as amended below:

903.2.1.1 Group A-1. An automatic sprinkler system shall be provided for Group A-1 occupancies where one of the following conditions exists:

1. The fire area exceeds 5000 square feet.
2. The fire area has an occupant load of 300 or more.
3. The fire area is located on a floor other than a level of exit discharge serving such occupancies.
4. The fire area contains a multi-theater complex.

903.2.1.3 Group A-3. An automatic sprinkler system shall be provided for Group A-3 occupancies where one of the following conditions exists:

1. The fire area exceeds 5,000 square feet.
2. The fire area has an occupant load of 300 or more.
3. The fire area is located on a floor other than a level of exit discharge serving such occupancies.
4. The structure exceeds 10,000 square feet, contains more than one fire area containing exhibition and display rooms, and is separated into two or more buildings by fire walls of less than four hour fire resistance rating without openings.

903.2.1.4 Group A-4. An automatic sprinkler system shall be provided for Group A-4 occupancies where one of the following conditions exists:

1. The fire area exceeds 5000 square feet
2. The fire area has an occupant load of 300 or more.
3. The fire area is located on a floor other than a level of exit discharge serving such occupancies.

903.2.2.1 Group B. An automatic sprinkler system shall be provided for Group B occupancies where the fire area exceeds 5,000 square feet.

903.2.3 Group E. Except as provided for in Section 903.2.3.1 for a new public school campus an automatic sprinkler system shall be provided for Group E occupancies as follows:

1. Throughout all Group E fire areas greater than 5000 square feet in area.
2. Throughout every portion of educational buildings below the lowest level of exit discharge serving that portion of the building.

Exception: An automatic sprinkler system is not required in any area below the lowest level of exit discharge serving that area where every classroom throughout the building has at least one exterior exit door at ground level.

3. In rooms or areas with special hazards such as laboratories, vocational shops and other such areas where hazardous materials in quantities not exceeding the maximum allowable quantity are used or stored.
4. Throughout any Group E structure greater than 10,000 square feet in area, which contains more than one fire area, and which is separated into two or more buildings by fire walls of less than four hour fire resistance rating without openings.

903.2.4 Group F-1. An automatic sprinkler system shall be provided throughout all buildings containing a Group F-1 occupancy where one of the following conditions exists:

1. A Group F-1 fire area exceeds 5000 square feet.
2. A Group F-1 fire area is located more than three stories above grade plane.
3. The combined area of all Group F-1 fire areas on all floors, including any mezzanines, exceeds 10,000 square feet.

903.2.7 Group M. An automatic sprinkler system shall be provided throughout buildings containing a Group M occupancy where one of the following conditions exists:

1. A Group M fire area exceeds 5000 square feet.
2. A Group M fire area is located more than three stories above grade plane.
3. The combined area of all Group M fire areas on all floors, including any mezzanines, exceeds 10000 square feet
4. A Group M occupancy is used for the display and sale of upholstered furniture.
5. The structure exceeds 10,000 square feet, contains more than one fire area containing a Group M occupancy, and is separated into two or more buildings by fire walls of less than 4-hour fire-resistance rating.

903.2.8.1 Group R-3 Substantial Addition or Expansion. An automatic sprinkler system shall be provided throughout all existing Group R-3 dwellings where a substantial addition or expansion occurs and the new total fire area of the structure exceeds 3,600 square feet.

903.2.9 Group S-1. An automatic sprinkler system shall be provided throughout all buildings containing a Group S-1 occupancy where one of the following conditions exists:

1. A Group S-1 fire area exceeds 5000 square feet
2. A Group S-1 fire area is located more than three stories above grade plane.
3. The combined area of all Group S-1 fire areas on all floors, including any mezzanines, exceeds 10000 square feet.

903.2.9.1 Repair garages. An automatic sprinkler system shall be provided throughout all buildings used as repair garages in accordance with Section 406 of the California Building Code, as shown:

1. Buildings having two or more stories above grade plane, including basements, with a fire area containing a repair garage exceeding 5000 square feet,
2. Buildings no more than one story above grade plane, with a fire area containing a repair garage exceeding 5000 square feet
3. Buildings with repair garages servicing vehicles parked in basements.

903.2.10 Group S-2 enclosed parking garages. An automatic sprinkler system shall be provided throughout buildings classified as enclosed parking garages in accordance with Section 406.4 of the California Building Code as follows:

1. Where the fire area of the enclosed parking garage exceeds 5000 square feet; or
2. Where the enclosed parking garage is located beneath other occupancy groups.

Section 903.3.1.1.2 is added to read:

903.3.1.1.2 Undeclared Use. In buildings of undeclared use with floor to structure height greater than 14 feet (356 mm), the fire sprinkler system shall be designed to conform to Extra Hazard Group I design density. In buildings of undeclared use with floor to structure height less than 14 feet (356 mm), the fire sprinkler system shall be designed to conform to Ordinary Group II design density. Where a subsequent occupancy requires a system with greater capability, it shall be the responsibility of the owner and/or the occupant to upgrade the system.

Section 903.3.5 is amended to add subsection 903.3.5.3 to read:

903.3.5.3 Non-permissible water supply storage. Swimming pools and ponds shall not be considered water storage for the purposes of Section 903.3.5.

Section 903.3.8 is added to read:

903.3.8. Floor control valves. Individual floor control valves and waterflow detection assemblies shall be provided for each floor in multi-floor buildings at an approved location.
Exception: Group R-3 and R-3.1 Occupancies

Section 903.4.2 is amended to read:

903.4.2 Alarms. One approved audible and visual device shall be connected to every automatic sprinkler system at an approved location. Such sprinkler water-flow alarm devices shall be activated by water flow equivalent to the flow of a single sprinkler of the smallest orifice size installed in the system. Audible and visual alarm devices shall be provided on the exterior of the building in an approved location. Where a fire alarm system is installed, actuation of the automatic sprinkler system shall actuate the building fire alarm system.

Section 903.6 is amended by adding subsections 903.6.3 and 903.6.4 to read:

903.6.3 Substantial Addition or Expansion. An automatic sprinkler system shall be provided throughout all existing buildings where a substantial addition or expansion occurs *and* the total fire area of the structure exceeds 5,000 square feet. Group R-3 substantial additions or expansions shall comply with Section 903.2.8.1.

903.6.4 Change of occupancy classification. Any existing building that undergoes a change of occupancy classification into a higher hazard category shall comply with the requirements of Section 903.2. Relative hazard categories of occupancy groups shall be established based upon the Heights and Areas Hazard Categories of Table 912.5 of the current edition of the International Existing Building Code, as published by the International Code Council. The requirements of Section 903.2 shall not be required when a change of occupancy classification is made to an equal or lesser hazard category. Group L occupancies shall be considered a relative hazard of 1 (highest hazard). R-3.x occupancies shall be considered a relative hazard of 4 (lowest hazard).

Section 907.5.4 is added to read:

907.5.4 Monitoring of other fire systems. In buildings equipped with a fire alarm system or sprinkler alarm and supervisory service (SASS) system, where other fire suppression or extinguishing systems are installed in the building (including but not limited to commercial kitchen suppression systems, pre-action fire suppression systems, dry chemical systems, and clean agent systems), these other suppression systems shall be monitored by the SASS dedicated function fire alarm system and transmitted as a specific signal to the Central Station. The system shall be monitored and comply with the UL Certification requirements contained herein.

Section 907.6.2.3.1 is amended to read:

907.6.2.3.1 Public and common areas. Visible alarm notification appliances shall be provided in public use areas and common use areas, including but not limited to:

1. Sanitary facilities including restrooms, bathrooms, shower rooms and locker rooms.
2. Corridors, hallways, aisles with shelving and/or fixtures obstructing the required light intensity for that area.
3. Music practice rooms.
4. Band rooms.
5. Gymnasiums.
6. Multipurpose rooms.
7. Occupational shops.
8. Occupied rooms where ambient noise impairs hearing of the fire alarm.
9. Lobbies
10. Meeting/Conference rooms.
11. Classrooms.
12. Medical exam rooms.
13. Open office areas.
14. Sales floor areas.
15. Break or lunch rooms
16. Copy or work rooms.
17. Computer server rooms exceeding 200 sq. ft.
18. File or Storage rooms exceeding 200 sq. ft.

Section 907.7.5 is amended to read:

907.7.5 Monitoring of fire alarm systems. A fire alarm system required by this chapter, or by the California Building Code, shall be monitored by a UL-listed Central Station service in accordance with NFPA 72 and this code.

Exception: Monitoring by a UL listed central station is not required for:

1. Single and multiple station smoke alarms required by section 907.2.11
2. Group I-3 occupancies shall be monitored in accordance with section 907.2.6.3.4
3. Residential Day Care Facilities (occupancy load of 14 or less)
4. One and two family dwellings
5. Residential Care Facilities licensed by the state with an occupant load of 6 or less.
6. Occupancies with a local fire alarm system that will give an audible and visible signal at a constantly attended location, as approved by the Fire Code Official.

Section 907.8.4 is added to read:

907.8.4 Certification. New fire alarm systems shall be UL-Certified. A Certificate of Completion and other documentation as listed in NFPA 72 shall be provided for all new fire alarm system installations. It is the responsibility of the building owner or owner's representative to obtain and maintain a current and valid Certificate.

Section 907.8.5 is added to read:

907.8.5 Posting of Certificate. The UL Certificate shall be posted in a durable transparent cover within 3 feet of the fire alarm control panel within 45 days of the final acceptance test/inspection.

Chapter 10. Means of Egress.

Section 1027.6 is amended by adding a new subsection 1027.6.1, to read:

1027.6.1 Exit discharge surface. Exterior exit pathway surfaces shall be suitable for pedestrian use in inclement weather, and shall terminate at a public way as defined in the California Building Code.

Chapter 14. Fire Safety During Construction and Demolition.

Section 1401.3 is added to read:

1401.3 Permits. Permits shall be obtained for asbestos removal operations, temporary fire department access roads for construction, and temporary water supplies as set forth in sections 105.6 and 105.7.

Section 1418 is added to read:

Section 1418 Asbestos removal.

1418.1 General. Operations involving removal of asbestos or asbestos-containing materials from buildings shall be in accordance with Section 1418.

Exception: Section 1418 does not apply to the removal of asbestos from:

1. Pumps, valves, gaskets and similar equipment.
2. Pipes, ducts, girders or beams that have a length less than 21 linear feet (6400 mm).
3. Wall or ceiling panels that have an area of less than 10 square feet (0.93 m²) or a dimension of less than 10 linear feet (3048 mm).
4. Floor tiles when their removal can be completed in less than four hours.
5. Group R-3 occupancies.

1418.2 Notification. The fire code official shall be notified 24 hours prior to the commencement and closure of asbestos-removal operations. The permit applicant shall notify the building official when asbestos abatement involves the removal of materials that were used as a feature of the building's fire resistance.

1418.3 Plastic Film. Plastic film that is installed on building elements shall be flame resistant as required for combustible decorative material, in accordance with Section 807.

1418.4 Signs. Approved signs shall be posted at the entrance, exit and exit-access door, decontamination areas and waste disposal areas for asbestos-removal operations. The signs shall state that asbestos is being removed from the area, that asbestos is a suspected carcinogen, and that proper respiratory protection is required. Signs shall have a reflective surface. Lettering shall be a minimum of 2 inches (51 mm) high.

Chapter 27. Hazardous Materials – General Provisions.

Section 2701.5 is amended by adding subsection 2701.5.3 to read:

2701.5.3 Emergency response support information. Floor plans, material safety data sheets, Hazardous Materials Management Plans (HMMP), Hazardous Material Inventory Statements (HMIS), and other

information must be stored at a readily accessible location, as determined by the fire code official. This location may be in cabinets located outside of facilities or buildings. Information may be required to be maintained in a specific electronic media format to facilitate computer aided dispatching.

Section 2703.9.1 is amended by adding subsection 2703.9.1.2 to read:

2703.9.1.2 Documentation. Evidence of compliance with provisions of this chapter as well as with state and federal hazardous material regulations shall be maintained on site and available for inspection by fire department personnel.

Chapter 33 Explosives and Fireworks.

Section 3301 is amended to add Sections 3301.2, 3301.3, 3301.4 and 3301.5, to read:

3301.2 Fireworks. The possession, manufacture, storage, sale, handling and use of fireworks are prohibited. The possession, manufacture, storage, sale, handling and use of fireworks or pyrotechnic materials within the jurisdiction of the District are prohibited.

Exceptions:

1. Fireworks may be temporarily stored only if they are aerial or theatrical piece fireworks stored in conjunction with an approved and permitted aerial or set display.
2. Snap Caps and Party Poppers classified by the State Fire Marshal as pyrotechnic devices.

3301.2.1 Prohibited and Limited Acts. The storage of explosive materials is prohibited in any central business district and in all zoning districts except districts zoned for industrial or agricultural uses. In districts where the storage of explosive materials is permitted, the quantities of explosives and distances shall be in accordance with International Fire Code Sections 3301.8.1 and 3301.8.1.1.

3301.3 Rocketry. The storage, handling and use of model and high-power rockets shall comply with the requirements of the California Code of Regulations, Title 19, Chapter 6, Article 17 and, when applicable, NFPA 1122, NFPA 1125, and NFPA 1127.

3301.3.1 Ammonium nitrate. The storage and handling of ammonium nitrate shall comply with the requirements of Chapter 40 and NFPA 490.

Exception: The storage of ammonium nitrate in magazines with blasting agents shall comply with the requirements of NFPA 495.

3301.4 Residential uses. No person shall keep or store, nor shall any permit be issued to keep or store, any explosives, fireworks or pyrotechnic material at any place of habitation, or within 100 feet (30 480mm) thereof.

Exception: Storage of smokeless propellant, black powder, and small arms primers for personal use and not for resale in accordance with Section 3306.

3301.5 Sale and retail display. The possession, manufacture, storage, sale, handling and use of fireworks or pyrotechnic materials is prohibited.

Exception: Snap Caps and Party Poppers classified by the State Fire Marshal as pyrotechnic devices.

Section 3308 is amended by adding Sections 3308.2 and 3308.3 to read:

3308.2 Permit required. A permit is required to conduct an aerial display in accordance with California Code of Regulations, Title 19, Chapter 6. (See Chapter 1, Section 105.6.52.)

Exception: Snap Caps and Party Poppers classified by the State Fire Marshal as pyrotechnic devices.

3308.3 Financial responsibility. Before a permit is issued pursuant to Section 3308.2, the applicant shall file with the jurisdiction a corporate surety bond in the principal sum of \$1,000,000 or a public liability insurance policy for the same amount, for the purpose of the payment of all damages to persons or property which arise from, or are caused by, the conduct of any act authorized by the permit upon which any judicial judgment results. The fire code official is authorized to specify a greater or lesser amount when, in his or her opinion, conditions at the location of use indicate a greater or lesser amount is required. Government entities shall be exempt from this bond requirement.

Chapter 34. Flammable and Combustible Liquids.

Section 3404.2.9.6.1 is amended to read:

3404.2.9.6.1 Locations where above-ground tanks are prohibited. The storage of Class I and II liquids in above-ground tanks outside of buildings is prohibited in all zoning districts except districts zoned for commercial, industrial, or agricultural uses.

Exception: Protected above-ground tanks for the purpose of emergency power generator installations in areas zoned commercial, industrial, agricultural, central business district, rural or rural residential, and for facilities on an individual basis consistent with the intent of this provision. Tank size shall not exceed 500 gallons (1892.706L) for Class I or II liquids, or 1,000 gallons (3785.412L) for Class III liquids.

Section 3406.2.4.4 is amended to read:

3406.2.4.4 Locations where above-ground tanks are prohibited. Storage of Class I and II liquids in above-ground tanks is prohibited in all zoning districts except district zoned for commercial, industrial, or agricultural use.

Chapter 35. Flammable Gases and Flammable Cryogenic Fluids.

Section 3506.2 is amended to read:

3506.2 Limitation. The storage of flammable cryogenic fluids in stationary containers outside of buildings is prohibited in any area which is zoned for other than industrial use.

Exception: Liquid hydrogen fuel systems in compliance with section 3506.3 or 3506.4.

Chapter 38. Liquefied Petroleum Gases.

Section 3803.2.1.7 is amended in its entirety to read:

3803.2.1.7 Use for food preparation. Individual portable L-P containers used, stored, or handled inside a building classified as a Group A or Group B occupancy for the purposes of cooking, food display, or a similar use, shall be limited in size to one quart capacity and shall be of an approved type. The number of portable containers permitted will be at the discretion of the fire code official. LP-gas appliances used for food preparation shall be listed for such use in accordance with the International Fuel Gas Code, the International Mechanical Code, and NFPA 58.

Section 3804.2 is amended to read:

3804.2 Maximum capacity within established limits. The storage of liquefied petroleum gas is prohibited in any central business district and in all zoning districts except districts zoned for commercial, industrial, rural, or agricultural uses. The aggregate capacity of any one installation used for the storage of liquefied petroleum gas shall not exceed a water capacity of 2,000 gallons (7570 L).

Appendix B. Fire-Flow Requirements for Buildings.

Section B105.2, the exception, is amended to read:

Exception: A reduction in required fire-flow of 50 percent, as approved by the fire code official, when the building is provided with an approved automatic sprinkler system and installed in accordance with Section 903.3.1.1. The resulting fire-flow shall be not less than 1,500 gallons per minute (5678L/min) for the prescribed duration as specified in Table B105.1.

Appendix C. Fire Hydrant Locations and Distribution.

Table C105.1 footnote f and g are added to read:

- f. A fire hydrant shall be provided within 250 feet of a fire trail access point off a public or private street.
- g. For infill projects within existing single-family residential developments, Section 507.5.1 applies.

Appendix D. Fire Apparatus Access Roads

Section D102.1 is amended to read:

D102.1 Access and loading. Facilities, buildings or portions of buildings hereafter constructed shall be accessible to fire department apparatus by way of an *approved* fire apparatus access road with an asphalt, concrete or other approved *all-weather driving surface* capable of supporting the imposed load of fire apparatus weighing at least 74,000 pounds (33 566 kg) in accordance with CalTrans Design Standard HS-20-44.

Exception: *Driveways* serving one or two single-family *dwelling*s may be constructed of an alternate surface material, providing the imposed weight load design minimums are met and the grade does not exceed 10 percent.

Section D103.1 is deleted in its entirety.

Section D103.2 is deleted in its entirety and replaced by the following, to read:

D103.2 Grade. Fire department access roadways having a grade of between 16 percent and 20 percent shall be designed to have a finished surface of grooved concrete sufficient to hold a 44,000 pound (19 958 kg) traction load. The grooves in the concrete surface shall be ½ inch (13 mm) wide by ½ inch (13 mm) deep and 1 ½ inch (38 mm) on center and set at a 30 to 45 degree angle across the width of the roadway surface. No grade shall exceed 20 percent, nor shall the cross slope exceed 8%, unless authorized in writing by the fire code official.

Section D103.2.1 is added to read:

D103.2.1 Angles of approach and departure. The angles of approach and departure for any means of access shall not exceed 10 percent at 10 feet of the grade break.

Section D103.3 is deleted in its entirety and replaced by the following, to read:

D103.3 Turning radius. Based on a minimum unobstructed width of 20 feet, a fire apparatus access roadway shall be capable of providing a minimum standard turning radius of 25 feet (7620 mm) inside and 45 feet (13 716 mm) outside.

ORDINANCE CONTINUES ON NEXT PAGE

Table D103.4 is amended to read:

**Table D103.4
REQUIREMENTS FOR DEAD-END FIRE
APPARATUS ACCESS ROADS**

LENGTH (feet)	MINIMUM WIDTH (feet)	TURNAROUNDS REQUIRED
0 – 150	20 ^a	None required
151 – 750	20 ^a	100-foot Hammerhead, 50-foot “Y”, 75-foot Shunt or 90-foot-diameter cul-de-sac in accordance with figure D103.1
Over 750		Special approval required ^b

- a. A driveway with a minimum width of 16 feet is acceptable for access to no more than two single-family dwellings.
- b. Any fire apparatus access roadway or driveway that is approved to be less than 20 feet wide and to exceed 750 feet in length shall have outsets or turnouts every 300 feet along the length of the road or driveway, or at locations approved by the fire code official. Each outset or turnout shall be of the following dimensions: an 8 foot wide turnout that extends at least 40 feet in length.

Figure D103.1 is amended to read:

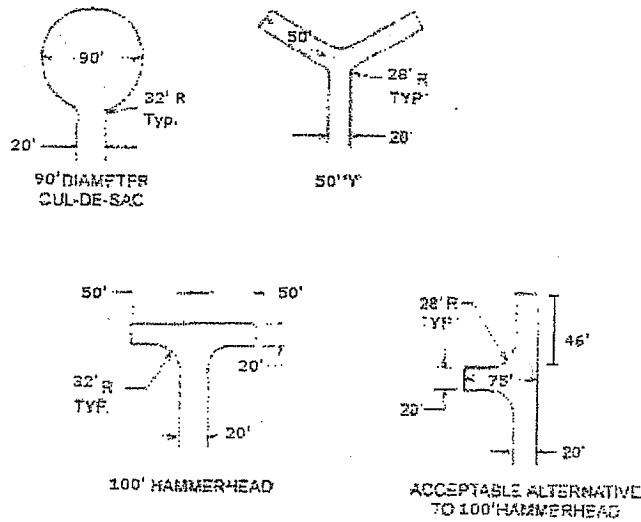

**Figure D103.1
Dead-end Fire Apparatus Access Road Turnaround**

Section D103.5 is amended by amending criteria 1 and adding criteria 10, to read:

1. The minimum clear width shall be 20 feet (6096mm.)

Exception: For access to one or two single-family *dwelling*s, 16 feet clear width is acceptable.

10. All gates shall be installed and located a minimum of 30 feet off the street.

Section D103.6.1 is amended to read:

D103.6.1 Roads less than 28 feet in width. Fire apparatus access roads less than 28 feet wide shall be posted on both sides as a *fire lane*.

Section D103.6.2 is amended to read:

D103.6.2 Roads 28 feet in width or greater, but less than 36 feet in width. Fire apparatus access roads 28 feet wide or greater, but less than 36 feet wide, shall be posted on one side of the road as a *fire lane*.

Section D106.1 is amended to delete the exception and read:

D106.1 Projects having more than 100 dwelling units. Multiple-family residential projects having more than 100 *dwelling units* shall be provided with two separate and *approved* fire apparatus access roads and shall meet the requirements of Section D104.3.

Section D106.2 is deleted in its entirety.

SECTION 3. REPEAL OF FIRE CODE.

Ordinance No. 2007-47, adopting the 2007 California Fire Code with amendments, is hereby repealed.

SECTION 4. VALIDITY.

The Contra Costa County Board of Supervisors declares that if any section, paragraph, sentence or word of this ordinance or of the 2010 California Fire Code as adopted and amended herein is declared for any reason to be invalid, it is the intent of the Contra Costa County Board of Supervisors that it would have passed all other portions or provisions of this ordinance independent of the elimination here from any portion or provision as may be declared invalid.

SECTION 5. MORE RESTRICTIVE REQUIREMENTS.

If requirements more restrictive than those in this fire code are adopted by the city of Antioch, Clayton, Concord, Lafayette, Martinez, Pittsburg, Pleasant Hill, San Pablo, or Walnut Creek, or the County of Contra Costa, those requirements will apply only within the jurisdiction adopting those requirements.

SECTION 6. EFFECTIVE DATE.

This ordinance becomes effective 30 days after passage, and within 15 days of passage shall be published once in the Contra Costa Times, a newspaper published in this County. This ordinance shall be published in a manner satisfying the requirements of Government Code section 25124, with the names of supervisors voting for and against it.

Passed on December 7 2010, by the following vote:

AYES: Wickema, Piepho, Howe

NOES: None

ABSENT: Asioia

ABSTAIN: District IV seat is vacant

ATTEST: David Twa,
Clerk of the Board of Supervisors
and County Administrator

Gayle P. Wickema
Board Chair

By: June Miller
Deputy

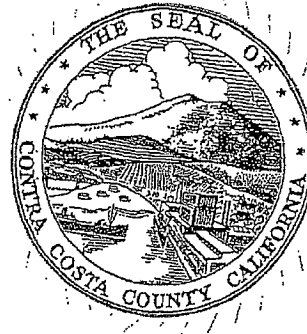

I hereby certify that this is a true and correct copy of an action taken and entered on the minutes of the Board of Supervisors on the date shown.

ATTESTED: December 13, 2010

DAVID TWA, Clerk of the Board
of Supervisors and County Administrator

By: Valerie Guclaw Deputy

**STAFF REPORT TO THE CITY COUNCIL
FOR CONSIDERATION AT THE MEETING OF FEBRUARY 28, 2012**

Prepared by: Mike Bechtholdt, Deputy Director of Public Works - Operations
Approved by: Ron Bernal, Director of Public Works/City Engineer **REB**
Date: February 22, 2012
Subject: Four Person Landscape Maintenance Crew Bid Award

RECOMMENDATION

Staff recommends the City Council award the Four Person Landscape Maintenance Crew (Bid No. 988-0202-12F) to the overall low bidder, Pacific Coast Landscape Management Inc., Brentwood, CA for \$599.00 per day (based on an 8 hour day) not to exceed \$150,000 per year for the term of five years.

BACKGROUND

The Department of Public Works published the request for bids on February 2, 2012. The bid closed on February 22, 2012. Nine contractors submitted qualifying bids. Pacific Coast Landscape Management, Inc. of Brentwood, CA, submitted the low bid of \$599.00 per day (based on an 8 hour day) over the five-year contract period of July 2012 through July 2017.

The four person crew will perform professional landscape maintenance services on a seasonal and as-needed basis. Department of Public Works staff will direct the contractor's work. These services will be provided at a fixed cost over the next five years and is primarily funded by the Landscape and Lighting District zones.

With the City's reduced landscape maintenance staffing levels, utilizing a contracted four person crew provides a cost effective way of maintaining the City's numerous landscaped areas. The recent progress we have made in providing a higher and more consistent level of landscape maintenance is due largely in part to the three and five-person crews the City has contracted to perform similar duties. The contractor is responsible for providing tools, equipment, vehicles, traffic control and insurance for their employees.

FISCAL IMPACTS

Funding for these services have been allocated in contract services for the remainder of FY2011/12 in the lighting and landscape districts budgets. Funding in FY 2012/13 through FY 2016/17 would be approved by Council out of the same funds in subsequent years. There are no impacts to the approved budgets.

OPTIONS

Council may choose to not approve the bid award. This option is not recommended. Not awarding this contract will limit City staff's ongoing efforts to provide the most cost effective landscape maintenance by maximizing limited funds and staff resources.

ATTACHMENTS

A: Bid tabulation

ANNUAL CONTRACT FOR 4 Person Trim Crew

BID NO. 988-0202-12F

BID CLOSING: Wednesday, February 22, 2012, 3:00 pm



<p>SPECIFICATIONS</p> <p>Cost for 4-person landscape crew to perform trimming work at various locations in Antioch at a daily rate. 8 hours/day hourly rate includes costs of materials, labor and equipment)</p> <p>4 Man Crew Per Hour</p>	<p>Pacific Coast 24695 Marsh Creek Road Brentwood, CA 94513 (925) 513-2310 Tim Schultz tschultz@pacificcoastlandscape.net</p>	<p>Commercial Environment Landscape 9110 Marcella Avenue Gilroy, CA 95020 (408) 848-9688</p>	<p>Anka Behavioral Health P.O. Box 315 Concord, CA 94522 (925) 674-9610 Adeel Ahmad aahmad@ankabhi.org</p>	<p>Pacheco Brothers 795 Sandavol Way Hayward, CA 94544 (510) 487-3580 Karl Pacheco karl@pachecobrothers.com</p>	<p>Odyssey Landscape Maintenance Division 800 W Eight Mile Road Stockton, CA 95209 (209) 369-6197 Dave Silva dsilva@odysseylandscape.com</p>	<p>New Image Landscape 3250 Darby Common Fremont, CA 94539 (510) 226-9191 aromero@newimagelandscape</p>	<p>Tree Sculpture Group 463 Roland Way Oakland, CA 94621 (510) 562-4000</p>	<p>JPA Landscape and Construction Inc. P.O. Box 1292 Pleasanton, CA 94566 (925) 960-9602 john.morrissey@jpalandscape.com</p>	<p>Long's Landscape 6223 Ridgemont Drive Oakland, CA 94619 Hai Nguyen (510) 866-5383 hnguyen481@gmail.com</p>
Fiscal year ending June 30, 2012	\$599.00	\$702.40	\$768.00	\$768.00	\$790.40	\$845.00	\$992.00	\$1,082.68	\$1,250.00
Fiscal year 2012/2013	\$599.00	\$702.40	\$768.00	\$790.00	\$790.40	\$845.00	\$1,006.00	\$1,110.40	\$1,285.00
Fiscal year 2013/2014	\$599.00	\$702.40	\$768.00	\$805.00	\$813.70	\$865.00	\$1,025.00	\$1,154.84	\$1,325.00
Fiscal year 2014/2015	\$599.00	\$708.80	\$768.00	\$820.00	\$813.70	\$885.00	\$1,050.00	\$1,212.60	\$1,375.00
Fiscal year 2015/2016	\$599.00	\$708.80	\$800.00	\$835.00	\$837.39	\$905.00	\$1,075.00	\$1,273.24	\$1,425.00
Fiscal year 2016/2017	\$599.00	\$708.80	\$800.00	\$850.00	\$837.39	\$925.00	\$1,100.00	\$1,349.64	\$1,475.00

* Overtime Rate in compliance with Prevailing Wage and DIR standards.

**STAFF REPORT TO THE CITY COUNCIL
FOR CONSIDERATION AT THE MEETING OF FEBRUARY 28, 2012**

Prepared by: Mike Bechtholdt, Deputy Director of Public Works - Operations
Approved by: Ron Bernal, Director of Public Works/City Engineer **REB**
Date: February 22, 2012
Subject: Chichibu Park Recycled Water Specific Retrofit Bid Award

RECOMMENDATION

Staff recommends the City Council award the Chichibu Park Recycled Water Retrofit contract (Bid No. 988-0202-12G) to the overall low bidder, Robert A. Bothman, Inc., San Jose, CA, in the amount of \$126,975 with funding provided by the Proposition 50, Integrated Regional Water Management Grant Program.

BACKGROUND

In order for Chichibu Park to be able to tie into recycled water from the recently completed DDSD/City of Antioch Recycle Water Project, some improvements must be made to meet requirements of the State of California. These include creating a new location for the picnic tables and barbeques that will not be impacted by the non-potable irrigation water. Attachment B shows the area where the existing grass will be removed and decomposed granite installed at this new, consolidated location. Trees are being added in to provide shade. Existing deteriorated asphalt paths are also being removed and replaced with decomposed granite which will prevent the recycled water from collecting and pooling. Other work includes irrigation modifications and replacing grass areas impacted by the work. Part of the project also involves removing and replacing the Dragon Post structure located at the north side of the park near the Longview Road entrance which has deteriorated beyond the point of repair.

Time is of the essence since the grant funding will expire at the end of March. The contractor is required to complete all work associated with the project prior to the funding deadline. Failure to complete the project prior to the funding deadline will result in liquidated damages requiring the contractor to compensate the City for lost funding.

The Department of Public Works published the request for bids on February 2, 2012. An onsite mandatory pre-bid conference was conducted on February 8, 2012. The bid closed on February 22, 2012. Two contractors submitted qualifying bids. Robert A. Bothman, Inc. of San Jose, CA, submitted the low bid of \$126,975.

Department of Public Works staff will direct the contractor's work which will have to be performed in a diligent manner to meet the mandated March 31st deadline for completion and invoicing.

FISCAL IMPACTS

Funding for this project has been allocated in the Water Fund in the current fiscal year budgets. We will be applying for reimbursement for this project from Proposition 50, Integrated Regional Water Management Grant Program. There are no impacts to the approved budgets. It is recommended that the Council approve a 10% contingency in the amount of \$12,697.50 in order to accommodate unforeseen field conditions or circumstances.

OPTIONS

Do not approve the bid award. This option is not recommended since failure to award the bid would negatively impact the City's grant funding application and result in the money necessary to accomplish this work to come from the Water Fund. Additionally, the recommended option is the most cost effective way to meet recycled water site-specific requirements which also completes several minor park safety improvements in the process.

ATTACHMENTS

- A: Bid tabulation
- B: Site Area Map

Chichibu Park Recycled Water Specific Retrofit

BID NO. 988-0202-12G

BID DUE DATE: Wednesday, February 22, 2012, 2:30 pm



<u>SPECIFICATIONS</u>	Robert A. Bothman 650 Quinn Avenue, San Jose, CA 95112 (408) 279-2277 George Gil aramos@bothman.com	Pacheco Brothers 795 Sandavol Way Hayward, CA 94544 (510) 487-3580 Karl Pacheco karl@pachecobrothers.com
	Hayward, CA 94544 (510) 487-3580	
Item #1 Decomposed Granite	\$102,025	\$120,000
Item #2 Irrigation	\$5,600	\$7,900
Item #3 Picnic Tables and BBQs	\$13,000	\$15,500
Item #4 Tree (6 each)	\$1,500	\$1,800
Item #5 Dragon Post Structure	\$3,850	\$7,550
Item #6 Garbage Cans	\$1,000	\$500
Discount		
Total	\$126,975	\$153,250
Attended Mandatory Pre-Bid Conference	Yes	Yes

* Overtime Rate in compliance with Prevailing Wage and DIR standards.

ATTACHMENT A



Attachment B

**STAFF REPORT TO THE CITY COUNCIL
FOR CONSIDERATION AT THE MEETING OF FEBRUARY 28, 2012**

Prepared by: Julie Haas-Wajdowicz, Environmental Resource Coordinator *JWH*
Reviewed by: Tina Wehrmeister, Community Development Director *TW*
Date: February, 1, 2012
Subject: City Council to Authorize "Keep Antioch Beautiful" Day as City Sponsored Event

RECOMMENDATION

Recognize April 21, 2012 as "Keep Antioch Beautiful" Day and add this event permanently to the City of Antioch: Event Policy as a City-Sponsored Event.

SUMMARY

Keep Antioch Beautiful (KAB) day is an annual city-wide litter cleanup event that was started in 2010 by former Councilmember, Martha Parsons. Over the past two years, the event has involved over 1200 volunteers who have removed over 11 tons of litter from our environment. The event is planned by a dedicated committee of volunteers and City staff, led by Mrs. Parsons. Mrs. Parsons and the rest of the planning committee wish to continue organizing this cleanup event well into the future.

This year, the event will be held on Saturday, April 21, 2012 from 8:30-11:30 am. We are also hoping to continue with a volunteer appreciation lunch following the cleanup. City sponsorship is requested in order to provide the needed staff participation and to confirm that the event will be covered by the City's liability insurance. Per the Event Policy that was approved by City Council on November 10, 2009, Council approval is needed for this to be a City Sponsored Event.

Municipal Regional Stormwater Permit Requirements

Keep Antioch Beautiful Day helps the City meet two requirements of the Municipal Regional Stormwater Permit (MRP) that we are currently under. Provision C.7.g requires the City to annually sponsor or host 3 community involvement events such as creek cleanups, adopt-an-inlet or other volunteer activities. Keep Antioch Beautiful counts as one of these events. Additionally, Section C.10 calls for a 40% reduction in trash entering the storm water system by 2015. In the calculation of measures used to achieve this goal, on-land cleanups are counted.

FINANCIAL IMPACT

This event will be run by volunteers with support from City Staff. No new funds are requested for the event, as the planning committee is working to gather financial and in-kind sponsorship for this event, including offsetting the cost related to staff time. Staff support for preparation and event day assistance will be approximately \$7,600 which includes the following: \$2,500 for Public Works (work alternative crew and/or staff already working that day); \$3,000 for overtime in the Police Department (two police officers working the event); \$1,500 for Community Development support (coordination efforts and event day help by Environmental Resource Coordinator); and \$600 for City Attorney, City Manager staff support.

OPTIONS

1. Approve Keep Antioch Beautiful Day as a City Sponsored Event for this year only.

ATTACHMENTS

A: City Event Policy

ATTACHMENT "A"

Approved by the Antioch City Council on 11/10/09

Revised by the Antioch City Council on 2/9/10

Revised by the Antioch City Council on 4/27/10

Revised by the Antioch City Council on 3/22/11

Revised by the Antioch City Council on 2/22/11

Revised by the Antioch City Council on 2/14/12

City of Antioch: Event Policy

1. City-Organized Events. The following events are examples of events organized by City staff on City property that are included in the particular department's annual budget. These events can use the City's name or logo, but all advertisements, brochures, etc. must receive City Manager approval in advance.

Child Safety Seat Inspection

Fall Fest at Prewett Family Park

Mayor's Golf Tournament to Support Scholarship Fund

Open House for Public Works Week

~~Triathlon at Prewett Park~~ (discontinued)

2. City-Sponsored Events. The following events are either City organized but not on City property or the City is jointly organizing the event with other organizations. Depending on the event, additional insurance and/or waivers from participants may be required. These events can use the City's name or logo, but all advertisements, brochures, etc. must receive City Manager approval in advance.

Coastal Clean Up

First Saturday Clean-up events

4/23/11 Keep Antioch Beautiful (Council Action on 3/22/11)

Memorial Day Parade

MLK Educational Competition Event

Veterans' Day Parade

3. City-Supported Events. The following events are supported with staff, supplies or equipment resources only unless specific financial grants are approved. These events are run by other organizations or individuals that will be required to ensure that the appropriate insurance coverage is in place and/or waivers obtained if requested by the City. The City's name or logo should not be used in advertisements or brochures unless approved in advance by the City Manager.

Blues Festival at Waldie Plaza

Cancer Society Relay for Life

East County Economic Development Summit

"Every 15 Minutes"

Holiday Delites with parade, tree lighting and some vendors

National Night Out

Neighborhood Watch Meetings

Police Activities League (PAL) events
Safety Fairs (e.g. at the Somersville Towne Center and other locations)
Sister City Program
Summer Concert Series at Prewett Family Park

4. Using the City's Name or Logo for Soliciting Donations. The following events or activities have not requested or received City support in the form of financial grant, staff assistance, supplies or equipment, but the City Council has given permission to use the City's name in fundraising efforts:

Fourth of July Celebration downtown including fireworks (City Council action on 4/27/10 and on 2/14/12 allowed a water bill insert to announce the event and fundraising with organization to pay the costs of insert 2/14/12)
3/28/10 and 3/27/11 Cesar Chavez Day (City Council actions on 2/9/10, 2/22/11 and 2/14/12)

5. City Lease of Facilities or Equipment. The City's rental of facilities or equipment to other organizations or individuals does not indicate City approval, sponsorship or support of the organization, individual or event. The use of the City's name or logo is not authorized in these situations.

6. Other Events. For events that are not listed above, the following protocols shall be followed:

- a. City Manager approval is required for the following:

- i. Any public event involving a direct City grant of City funds (grants of \$1000 or more require City Council approval); or
- ii. Any public event involving expenditures for staff time, supplies, equipment or waivers of typical rental fees (expenditures of \$5,000 or more require City Council approval), excluding staff resources solely for reviewing use permits or special event permits; or
- iii. Any event for which the organizers desire to have the City publicly identified as a sponsor or supporter in advertisements, brochures, etc. However, if such City identification will be used for fundraising/donation purposes, then City Council approval will be required.

Approval of these events shall indicate the level of City involvement as categorized above, if any, and any requirements regarding insurance, waivers, advertising, etc.

- b. City Council approval is required for the following:

- i. Any public event involving a direct City grant of City funds of \$1,000 or more; or

- ii. Any public events involving an estimated expenditure of \$5000 or more, including estimated costs for staffing, supplies or equipment excluding staff resources solely for reviewing use permits or special event permits.
- iii. Use of the City's name or logo for fundraising or donation purposes.

Approval of these events shall indicate the level of City involvement as categorized above, if any, and any requirements regarding insurance, waivers, advertising, etc.

**STAFF REPORT TO THE MAYOR AND CITY COUNCIL FOR
CONSIDERATION AT THE MEETING OF FEBRUARY 28, 2012**

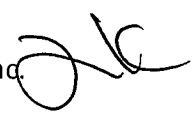
Prepared by: Lonnie Karste, Project Consultant – Karste Consulting Inc. 

Reviewed by: Jim Jakel, City Manager
City Council/Antioch Golf Corporation Board Subcommittee

Date: February 10, 2012

Subject: Lone Tree Golf Course City Council Subcommittee Report

RECOMMENDATION

1. The Antioch Golf Corporation payment of the 2001/02 ABAG loan shall be the top debt service priority. Review annually.
2. Defer all other loan payments until after the ABAG loan payments are current. Review annually.
3. Seek an alternate funding source for the reclaimed water costs for the course (approximately \$90,000 per year). Review annually.
4. A review of the golf course operational budget to be done annually by an Ad-hoc Subcommittee, prior to approval by their Board of Directors.
5. Review "Summary" section of this report and provide direction.

BACKGROUND INFORMATION

At the City Council meeting on May 24, 2011, Mayor Davis raised the issue of the establishment of an Ad-Hoc Subcommittee to work with the Board of Directors of the Lone Tree Golf Course & Event Center.

At the meeting July 26, 2011, Mayor Davis appointed himself and Mayor Pro-Tem Harper to the Ad-Hoc Subcommittee related to the Lone Tree Golf Course & Event Center.

The first Subcommittee meeting was held on August 25, 2011.

The Objectives Developed by the Subcommittee

1. Understand the history of this public golf course. This is a physical asset owned by the City and managed by a non-profit board of directors.
2. Further enhance lines of communication between the City Council and the Antioch Golf Corporation.
3. Review and develop an understanding of the golf course's operational budget/revenue projections and discuss the impacts of decisions made by both the City Council and the Golf Board on the general fund budget of the City of Antioch.

4. Review the irrigation water use costs and the impact of the reclaimed/recycled water project on the golf course operations and budget.
5. Review the current loan obligations of the golf course and the impact of those loans on the golf course operations and the City of Antioch's general fund.
6. Discuss the community benefit of this facility for the residents of Antioch.
7. Develop a cooperative working relationship with the City of Antioch's Recreation Department to cross market the golf course and community center

History of the Relationship

In 1982 the City of Antioch transferred operations of the Lone Tree Golf Course to Antioch Golf Corporation Inc., a non-profit board of director's. This transition occurred because the city lacked the experience and staff to maintain the facility properly and the course was falling into a state of disrepair.

The following conditions were stipulated in that original agreement.

- The City would remain owner of the facility.
- Public course – with reduced fees to Antioch residents.
- Water was to be provided to the course for irrigation – free of charge by the City of Antioch.
- No changes could be made to the course without City Council approval.
- The city would keep responsibility for road maintenance, from Lone Tree Way (now Golf Course Road) to the Golf Course parking lot.

In 2001/02 a new agreement was established with Antioch Golf Corporation, Inc. the following actions were part of that agreement:

- The City Council approved the design, size and construction of a new event center.
- The project is bid as a public project – low bidder was reviewed and approved by the City staff.
- The new clubhouse/event center construction was funded by ABAG Loan 2001/02. A \$6.3M loan was taken to pay off ABAG loan XXV and fund construction of the new clubhouse and event center– debt to be repaid in 2031.
- The selected contractor defaulted during construction – cost overruns occurred and an additional \$900,000 was required to complete the project – this was loaned by the City.
- Oversight on the project by city staff during the construction was very limited.
- Water charges for raw water – \$100,000 per year, 4% escalator until 2010.

In 2006 Antioch Golf Corporation, Inc. entered into litigation with the contractor (payment dispute for the event center construction). These legal fees impacted Antioch Golf Corporation, Inc.'s operational budget/reserves and began to create some exposure for the City of Antioch.

Two new courses in the area became fully operational – Deer Ridge and Shadow Lakes, along with existing courses, Roddy Ranch, Brentwood and Lone Tree.

In 2008 the City commissioned a management report from a golf course operations consultant (NGF) with regard to the operations and management of the Lone Tree Golf Course.

At that time the report indicated that the current operation under the direction of the volunteer Antioch Golf Corporation Board of Directors was a solid model for this public course. The report also indicated that the current operations were sound. It concurred that the current golf market in the area had been saturated by an abundance of new golf courses and had impacted the previous market share of the golfers that Lone Tree Golf Course had enjoyed when the clubhouse expansion had been planned and construction had begun.

While not specifically outlined in the report, discussions with the NGF consultants also suggested that the 2001/02 ABAG loan payments on the new clubhouse/event center could have a significant impact on the operational budget for the golf course. This, in conjunction with the downturn of the economy and the saturation of the relatively new golf opportunities in the area, could create problems with the original financial modeling for the new facility.

Please see the Council staff report provided by former Assistant City Manager Arlene Mornick (Attachment "A").

The Water Use

As part of that original 1982 agreement between the City of Antioch and the Antioch Golf Corporation, the water would be provided free to the golf course for irrigation.

In 2002/03 the agreement was modified including a provision that the golf course would be responsible for payment of its water use up to \$100,000 per year with a 4 % escalator each year until 2010.

In June 2009 to assist the Antioch Golf Corporation with financial challenges, the City Council approved treating the Golf Course irrigation water bill as it would any other city park, waiving the irrigation fees until July 2010 at which time the Corporation's ability to pay would be reevaluated.

During the City Council meeting of July 14, 2010, the Council received a report from staff recommending the continuance of the waiver of payment of the irrigation water bill at the Lone Tree Golf Course.

As a part of that report, the Antioch Golf Corporation presented the City Council with their latest financial outlook. The City Council raised concerns regarding continuing the waiver of the water bill based on the figures provided by the Golf Course. The City Council did approve the waiver of the irrigation water bill through September 2010, and asked that the issue be brought back at that time. At that next meeting, staff recommended continuing the waiver of the irrigation water bill until it formally transitions to Delta Diablo Sanitation District with completion of the Reclaimed/Recycled Water Project. Staff expected this to occur in October 2010.

The City Council then received a report at the council meeting of September 14, 2010, recommending an additional extension of the waiver of payment for the irrigation water bill at the Lone Tree Golf Course until completion of the Reclaimed/Recycled Water Project. The project completion was originally expected to be complete in October 2010, but they were experiencing some delays. The Lone Tree Golf Course finally began the use of reclaimed water in August 2011.

The New Reclaimed Water Use

The City of Antioch embarked on the reclaimed/recycled water project to provide irrigation to median landscaping, several parks and the golf course. The Lone Tree Golf Course was a major part of this large capital project. The intent was to transfer its irrigation water supply from treated water from the City of Antioch to reclaimed water provided by Delta Diablo Sanitation District. This project would reduce the demand on the more expensive treated water and produce a reliable source of irrigation (drought resistant) to the golf course during the peak demand use time from April – October.

The cost to both the City of Antioch and the golf course for the use of reclaimed/ recycled water is significantly much lower than raw or treated water costs currently experienced by the city for the golf course irrigation. The Antioch Golf Corporation is now responsible for the costs of the recycled water used onsite for irrigation during the peak periods (April – October) and the treated water costs used during the remainder of the year.

Golf Course Debt Obligation

ABAG Loan

There were a series of ABAG loans related to the golf course operation and capital improvements over the past 28 years – those loans are listed below:

1. First ABAG loan III 1984 – \$235,000 – sewer line and water line installation, gas line installation and cable TV connection – repaid with ABAG XXV loan 1992.
2. Second ABAG loan XXV 1992 – \$1.48M – repay 1984 ABAG loan and construct a new course irrigation system.

3. Third ABAG loan 2001/02 – current balance \$5,240,000 – includes refinancing of the previous loans ABAG III and ABAG XXV, and the construction of the Lone Tree Golf Course clubhouse/event center. Final payment due 7/1/31.

City of Antioch Loans to the Golf Course

1. Parking lot improvement loan in conjunction with the event center construction project – total amount due \$222,165.00.
2. Clubhouse/event center cost overrun construction loan – total amount due \$900,000.00.

Current Outstanding Loan Payment Balances:

1. 2001/02 ABAG loan as of January 2012 – \$541,761.00.
2. Golf course construction loan due in 2011 – \$8,910.00 – interest only.
3. Parking lot loan, due in 2011 – \$74,055.00.

Upcoming Payments Due:

1. 2001/02 ABAG loan payment due June 2012 – \$281,063.00.
2. City of Antioch loan – parking lot loan payments due June 2012 – \$74,055.00.
3. City of Antioch loan – clubhouse/event center construction principal and interest payment due January 2012 – \$ 48,379.00.

The 2001 ABAG loan is the only third-party loan in this equation. The parking lot renovation and clubhouse/event center loans were made by the City of Antioch to the Antioch Golf Corporation.

As a City asset the 2001/02 ABAG loan for the improvements to the golf course is the responsibility of the City of Antioch. Any operator would be impacted by this debt – private contractor, non-profit or the City itself.

Lone Tree Golf course Operational Budget Review

The subcommittee has reviewed the operational budget of the Lone Tree Golf Course for the fiscal year 2010/11 and 2011/12, and identified a few areas of possible revenue enhancements and expense reductions. The Antioch Golf Corporation Board of Directors has realized several successes over the past three years based on the 2008 NGF consultants' report and the subcommittee suggestions. Those adjustments are as follows:

- Reduction in employees – 4 FTE and 2 PT.
- Elimination of General Manager position.
- Dual department management (combining departmental duties to save on wages).

- Event service fees restructure (20% more kept in-house). This could produce a revenue increase to operations of \$25K.
- Winter staffing adjustments (salaried employees began cover of hourly employee shifts to reduce labor costs).
- Modified maintenance program – mowing of turf.
- Catering department reorganized to provide better service, while also focusing on off-site catering (huge opportunity for profitability).
- Reduced cost on facility repairs through proactive maintenance.
- Parking lot maintenance is being done by in-house employees.
- New revenue from the newly constructed lighted driving range – November 2011.

Please find the budget comparison overview on Attachment “B”.

Community Benefits:

- Facility management provided by a volunteer non-profit board of directors, made up of business owners, professionals, a non-profit executive, former marketing professional and a former public employee manager.
- Management and staff participation, leadership and networking in various organizations i.e. Rotary, Chamber of Commerce, First Tee, Regional Superintendents Association, Professional Golfers Association.
- Provides employment to 26 FT employees and 56 PT employees

Provides a Venue for:

- Boys and girls golf teams for Deer Valley High and Antioch High Schools.
- Fundraising tournaments for a variety of local charities and organizations including the Antioch PAL and Mayor’s Cup golf tournaments.
- Hosts Junior Golf Association of Northern California tournament.
- Golf events for travelling golf groups from outside of area.
- Northern California Golf Association top level amateur competitions, drawing amateurs from the Nor-Cal Area.

Ongoing Uses:

- Golf experience for Antioch residents.
- Provides weekly play for Seniors Golf Club, three different Ladies Groups.
- Provides facility for weekly service club meetings (Morning Rotary, Lunch Rotary, BNI, BCN, and Soroptimist).
- Antioch Golf Club tournaments and events.
- Monthly couples golf events.
- New golfer clinics through the Antioch Recreation Department and individual instruction.

Special Uses/ Events:

- City of Antioch events – State of the City luncheon, Mayors Conference, etc.
- Holiday caroling party supporting local choirs.
- Holiday Breakfast with Santa and Toys for Tots Drive.
- Facility for fine weddings, reunions, celebrations, educational seminars and memorials.
- Community charity and fundraising donations of golf and brunch.
- Music by the Green – a weekly social event to attract new customers.

Positive Youth Activities:

- Primary First Tee facility for Contra Costa County Chapter.
 - Spring, Summer, Fall sessions for 300+ kids annually.
 - Multiple Lone Tree participants recognized for national programs and camps (2011: National Leadership Academy x 2; Hank Haney Players Academy x 1; PGA Senior Tour First Tee Pebble Beach x 1).
 - First Tee scholarships for session fees and golf clubs for kids.

SUMMARY

The City Council Subcommittee has reviewed the current financial obligations of the Lone Tree Golf Course and their current operating budget and revenue projections for the past two years to the current year. They have developed an understanding of the challenges facing both groups and the positive efforts being made on behalf of the community. As a result of these discussions and reviews they have concluded the following:

1. The Lone Tree Golf Course and Event Center is currently confronting a number of challenges.
 - ABAG loan debt.
 - Downturn in the economy.
 - Saturated golf market.
 - Creating a larger event center facility desired by the community leaders.
 - Irrigation water costs.
 - The new Antioch Community Center.
2. The Antioch golf corporation board of directors has made and continues to make significant strides to improve the operations of the golf course in a fiscally conservative manner while trying to maintain quality of the course and excellent customer service.
3. The Antioch Golf Corporation Board of Directors is making a strong push to improve revenue generation of the facility through an aggressive marketing campaign and program expansion.
4. The golf course provides a benefit to the community and its stakeholders.

5. The lines of communication now established by this subcommittee need to be maintained on a regular basis with reports to the City Council.
6. They also recommend the following:
 - a. The Antioch Golf Corporation prioritizes the payment of the 2001/02 ABAG loan.
 - b. Defer all other loan payments until after the ABAG loan payments are current.
 - c. Seek an alternate funding source for the future reclaimed water costs for the course.
 - d. The ad-hoc subcommittee reviews the golf course operational budget annually prior to approval by the board of directors.
7. Consider appointing a City Council member as an ex-officio member of the Antioch Golf Course Corporation Board of Directors.

ATTACHMENTS

Attachment "A" – 2008 NGF Recommendations/Staff Report to the City Council
Attachment "B" – LTGC Budget Comparison

**STAFF REPORT TO THE MAYOR AND CITY COUNCIL FOR
CONSIDERATION AT THE COUNCIL MEETING OF JANUARY 27, 2009**

FROM: Arlene Mornick, Assistant City Manager *AM*

REVIEWED BY: Jim Jakel, City Manager *JJ*

DATE: January 20, 2009

SUBJECT: Receive and File Report from National Golf Foundation (NGF)
Consulting regarding Operational Review and
Recommendations for Lone Tree Golf & Event Center

RECOMMENDATION

It is recommended that City Council receive and file the consultant report regarding the Operational Review and Recommendations for City of Antioch Golf Operation at Lone Tree Golf and Event Center

SUMMARY

In July 2008, the City of Antioch entered into a contract with NGF Consulting to perform a review of the Lone Tree Golf Course. The purpose of this contract was threefold: first, to commence a study that would review and, if appropriate, suggest operational changes; second, to provide a long term business plan to assist the new management of the facility; and finally to perform a market analysis with resulting recommendations for appropriate market positioning of Lone Tree Golf Facility.

The report has been completed. The findings, for the most part, are very positive of the facility, the operating structure and the new management. The first twenty pages have an Executive Summary of the findings and recommendations. Therefore, this report will highlight the most significant.

Findings:

- The basic operation and governance structure (Non-Profit Organization) of the facility is sound.
- New Management is forward looking, focuses on good service, looks to enhance revenues and control expenses.
- The Lone Tree Golf & Event Center has been operating at close to a "breakeven" level for the last few years, even in light of unanticipated legal expenses. This trend will be challenged by the current economic situation in the bay area.
- Due to the nature of the competitive golf market and the state of the local economy, the NGF Consulting team's recommendations center on enhancement of activity levels and increased volume in the event center rather than simply increasing fees.

F
1-27-09

- Successful golf operations typically allocate 3 – 5% of their revenue to marketing. The new management has implemented a marketing strategy and is budgeted to spend approximately 2.5% of gross revenues. A marketing emphasis is critical to creating awareness, correcting misperceptions in the market, and increasing daily fee and tournament play. An effective and comprehensive marketing plan must incorporate research, planning, strategy, market identification, budget advertising, timetable and follow-up. Advertising should be tracked adequately to gauge its effectiveness.
- Food & Beverage Operations may consider eliminating the main dining room's use as a dinner restaurant and focus on building the high margin banquet and catering business; making the Bar/Lounge area friendly and receptive to golfing patrons to partake in food and drink. Several improvements recommended in the report will enhance the clubhouse experience.
- A high volume of banquet business can be especially critical to the financial health of a golf course in today's competitive environment, as this type of business is typically at a high operating margin, and can offset losses in other areas. Direct selling and marketing are crucial to the success of the banquet operations.
- Continue to promote and host tournaments and outings. Direct selling and marketing are crucial to the success of drawing large events.
- Lone Tree Golf Course is generally priced appropriately, given its value proposition relative to its primary competitors.
- Increase women's participation in the golf course activities. There are several recommendations in the report geared toward female-friendly golf facilities. Included in those recommendations is the importance of adding a new forward set of tees.
- NGF Consulting compiled surveys of area residents and others on their opinions regarding the Lone Tree Golf & Event Center. The results are summarized in the report and almost all measures show ratings that are well above average. It is suggested that a periodic survey become part of the measure of how the Facility is meeting its goal.

In summary, the new Management and Board of Directors are on the right track regarding the operations of the facility. The focus must remain on advertising and marketing to increase the activity of the center. There are several recommendations of physical enhancements, which if accomplished, will augment the experience of patrons visiting the facility.

The biggest issue facing the facility at this time, however, is that with which all businesses and governments are faced: the economy. In light of the current economic and competitive market conditions, it appears unlikely that the Facility will continue to produce revenue sufficient to meet operating costs. The management and Board of Directors have already taken steps to decrease expenditures. The number of staff members has been reduced; others have taken a reduction in pay; maintenance efforts have been reduced as much as possible without sacrificing the charter of the Facility. Whether or not this is sufficient remains to be seen. At a future meeting of the City

Council, the Management and Board of Directors will present a financial and operating update.

FINANCIAL IMPACT

At this time there are no financial impacts.

ATTACHMENTS

Attachment A: Summary of Significant Findings (Council has already received the report in its entirety)

Lone Tree Golf & Event Center
 Previous Years Budget vs Actual
 Current Years Budget vs Projected

ATTACHMENT B

	2010-11 Budget	PY Actual	2011-12 Budget	Current Year Projected
Revenue				
Pro Shop Sales	196,598	206,014	218,756	203,821
Green Fees	1,233,261	1,099,274	1,154,051	1,174,937
Cart Fees	371,849	297,203	309,551	297,721
Range Fees	150,707	131,105	189,500	162,544
Beer	166,240	167,425	164,500	152,458
Wine	70,620	68,636	74,600	69,579
Liquor	163,070	150,074	158,800	147,317
Food	1,209,000	1,214,749	1,337,000	1,165,094
Miscellaneous	76,385	62,438	60,400	65,159
Total Revenue	3,637,730	3,396,918	3,667,158	3,438,630
Cost of Goods Sold				
Pro Shop	139,584	149,890	155,317	145,322
Beer	51,534	55,303	52,640	46,940
Wine	22,598	22,992	23,872	22,671
Liquor	36,758	36,302	36,524	34,174
Food	374,790	394,427	414,470	367,122
Total Cost of Goods Sold	625,264	658,914	682,823	616,229
Gross Profit	3,012,466	2,738,004	2,984,335	2,822,401
Expenses				
Equipment Maintenance	35,000	24,810	25,550	23,540
Repairs & Maintenance	43,936	34,739	33,900	25,045
Cart Maintenance	6,300	6,402	3,300	5,829
Fuel	17,400	25,044	22,600	22,733
Dues, Seminars & Travel	22,703	20,865	18,110	22,029
Taxes & Licenses	4,789	4,808	4,085	4,015
Uniform-Laundry	39,772	32,200	31,932	30,695
Clubhouse Maintenance	7,500	15,359	17,100	21,308
General Suplies & Small Tools	135,323	126,899	126,451	122,769
Irrigation Supplies	34,960	20,674	29,200	28,813
Chemicals & Fertilizer	33,000	31,630	28,375	28,926
Seed, Sand & Plant	30,000	13,820	9,600	9,106
Promotion	100,040	118,098	35,700	35,746
Advertising	-	-	84,400	70,539
Equipment Rental	106,258	113,586	123,704	117,426
Utilities	145,008	152,998	161,250	150,098
Lesson Income	(48,735)	(34,266)	(43,200)	(27,253)
Lesson	39,850	27,941	34,600	22,388
Gratuity Income	(143,065)	(157,437)	(165,785)	(145,927)
Gratuity	125,897	135,169	149,216	105,329
Wages - Salary	544,628	474,107	490,871	444,072
Wages - Hourly	767,764	844,442	857,821	855,887
Wages- Vacation	19,680	7,560	2,500	1,200
Payroll Taxes	152,279	155,207	155,999	135,294
Simple IRA	11,085	6,382	8,412	9,069
Medical & Dental Insurance	161,613	142,490	139,644	152,707
Employee Benefits	11,539	8,304	12,300	9,620
Workers Comp Insurance	54,103	50,954	74,816	63,922
General Insurance	35,190	34,609	39,027	38,821
Bank Charges & Loan Fees	56,933	60,028	59,448	58,950
Interest Expense	271,421	272,478	263,726	264,073
Mayors Cup Expense	2,522	3,435	2,000	1,000
Legal and Accounting	2,100	1,460	1,500	1,035
Irrigation Water	120,000	-	86,000	-
Returned Checks-Bad Debt		3,229	-	-
Over-Short		(407)	-	-
Total Expenses	2,946,793	2,777,617	2,924,152	2,708,804
Misc Income/Expense	24,100	24,072	27,100	30,016
Net Income	89,773	(15,541)	87,283	143,613

**STAFF REPORT TO THE ANTIOCH CITY COUNCIL FOR
CONSIDERATION AT THE MEETING OF FEBRUARY 28, 2012**

Prepared by: Dawn Merchant, Finance Director

Reviewed by: Jim Jakel, City Manager

Date: February 21, 2012

Subject: Police Department Staffing

RECOMMENDATION

Provide direction to staff regarding police department staffing.

BACKGROUND

At the council meeting on February 14th, an update on the City’s crime statistics was presented by Chief Cantando. Several concerns regarding staffing at the police department were raised. As mentioned, the Chief has received authorization to proceed with filling two vacant police officer positions. The purpose of this report is to provide Council with current funded and actual staffing levels at the police department, as well as provide the salary and benefit cost of a Police Officer and Community Service Officer (CSO).

SUMMARY

The following table details the authorized, funded and actual staffing levels at the police department as of today.

Position	Authorized FTE	Budgeted FTE	Filled FTE	Funded Vacancies	Total Vacancies
Police Chief	1.00	1.00	1.00	0.00	0.00
Captain	2.00	1.00	1.00	0.00	1.00
Lieutenant	6.00	5.00	5.00	0.00	1.00
Sergeant	12.00	10.00	9.00	1.00	3.00
Corporal	7.00	5.00	5.00	0.00	2.00
Officers	98.00	75.00	72.00	3.00	26.00
Community Service Officers	20.00	0.00	0.00	0.00	20.00
Communications/Records Supervisor	1.00	1.00	0.00	1.00	1.00
Crime Data Technician	1.00	1.00	1.00	0.00	0.00
Dispatcher Lead	4.00	4.00	4.00	0.00	0.00
Dispatcher	13.00	11.00	10.00	1.00	3.00
Secretary	10.00	6.00	6.00	0.00	4.00
Personnel Technician	.50	.50	.50	0.00	0.00
Total Budgeted/Funded FTE's	175.50	120.50	114.50	6.00	61.00

While there are a total of 61 vacancies throughout the police department, six of those vacancies are funded in the 2012 and preliminary 2013 budget. Vacancies have arisen as a result of attrition in the department. As you can see, there are currently three vacancies

of funded Police Officer positions. The City is moving forward with the recruitment of two of those positions.

The cost of funding the base salary and benefits of a Police Officer at Step C is approximately \$132,000 per year. This does not include any overtime or special compensation (such as educational incentive, longevity pay, etc.) that the officer may be entitled to. The cost of funding the base salary and benefits of a CSO at Step C is approximately \$84,000 per year. There is a 5% differential between steps of both positions should someone be hired below or above Step C. There may also be additional equipment and supply costs incurred (vehicles, etc.) in order for the positions to fully perform their duties.

The budget process is in the beginning stages, and all information from departments is still being compiled to prepare the most current General Fund projections for this year and the next two fiscal years. Very preliminary numbers reflect a \$116,000 surplus in this fiscal year with a projected ending fund balance of approximately \$6.9M and a \$1.9M deficit in FY13 with a projected ending fund balance of approximately \$4.9M. These numbers will change once all departmental budgets are updated, but it is difficult to determine by how much at this time. Any staffing levels increased beyond those budgeted will have a direct impact on the amount of surplus and/or deficit and fund balance in the General Fund now and going forward.

Staff is requesting Council to provide direction regarding police department staffing levels.

OPTIONS

1. Expand hiring beyond two officers once an eligibility list is established.
2. Hire CSO positions in lieu of hiring additional officers beyond the two currently authorized.
3. Postpone decision to increase any staffing (beyond the two authorized) at the police department until after budget study sessions begin for the General Fund to have the most updated financial projections and impacts of hiring.

**STAFF REPORT TO THE CITY COUNCIL
FOR CONSIDERATION AT THE MEETING OF FEBRUARY 28, 2012**

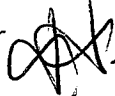
Prepared by: Tina Wehrmeister, Community Development Director 
Reviewed by: Jim Jakel, City Manager 
Date: February 23, 2012
Subject: Computer Gaming and Internet Access Businesses

RECOMMENDATION

It is recommended that the City Council:

1. Motion to read the Interim Urgency Zoning Ordinance, Urgency Ordinance and Regular Ordinance by title only;
2. Motion to adopt the attached Interim Urgency Zoning Ordinance prohibiting the issuance of permits, licenses or approvals for construction, establishment or operation of any computer gaming and internet access business within the City of Antioch on an interim basis pending consideration of amendments to Title 9 of the Antioch Municipal Code for a period of forty-five days and declaring the urgency thereof (four-fifths vote required) (Attachment "A");
3. Motion to adopt an Urgency Ordinance amending Title 5 of the Antioch Municipal Code by adding Chapter 11 pertaining to the licensing procedures and regulations for Computer Gaming and Internet Access Businesses and making findings declaring the urgency thereof (four-fifths vote required) (Attachment "B");
4. Motion to introduce a Regular Ordinance amending Title 5 of the Antioch Municipal Code by adding Chapter 11 pertaining to the licensing procedures and regulations for Computer Gaming and Internet Access Businesses (majority vote required) (Attachment "C"); and
5. Motion to adopt a resolution to initiate an amendment to the Zoning Ordinance to address computer gaming and internet access businesses (majority vote required) (Attachment "D").

BACKGROUND INFORMATION

Operations at Internet Room, T's Internet Café and Cot on the Web

During the past two years, the City received business license applications for the Internet Room (2962 Delta Fair Boulevard), T's Internet Café (1908 A Street and previously at 1836 A Street and 1653 A Street) and Cot on the Web (2333 Buchanan Road), which were described as offering "print, copy, fax services and internet access" or "internet sales" (Attachment "E"). In effect, City staff envisioned Kinko's-like businesses offering copying, computer and fax services

to small businesses and individuals and thus the businesses were allowed to open as permitted uses at the given locations.

However, the City began receiving complaints regarding nuisance and illegal activities occurring in and near these facilities, such as loitering, vandalism, panhandling, theft, and assaults. The Police Department prepared a summary chart showing calls at each location and the surrounding vicinity before and during the time the use opened (Attachment "F"). Of particular note, at 1836 A Street, before T's Internet Café opened there were 157 calls for service from that location and neighboring businesses over a 7-month period from February 1, 2009 through August 30, 2009. While T's Internet Café was operating at 1836 A Street, calls for service increased to 240 (a 52% increase) over a 7-month period from February 1, 2010 through August 30, 2010. When T's Internet Café closed at that location, calls for service from that location and neighboring businesses went back down to 158 calls for service over the 7-month period from February 1, 2011 through August 30, 2011, almost identical to the rates before T's Internet Café opened.

Attachment "G" shows 9-1-1 calls for service at each location. The Police Department also indicates that the following number of arrests were made at each location for the given time period. This does not mean that all of the arrested individuals committed crimes at these locations, but reflects that those engaged in criminal activity frequent these locations. The arrests were for violations including robbery, illegal drug use and sales, burglary, assaults, public intoxication, as well as arrests for outstanding warrants:

<u>Business</u>	<u>Location</u>	<u>Time Period</u>	<u># Arrests</u>
Internet Room	2962 Delta Fair Blvd.	2/116/11-02/15/12	2
T's Internet Café	1908 A Street	08/20/11-12/31/11	9
T's Internet Café	1653 A Street	09/01/10-08/31/11	14
T's Internet Café	1836 A Street	03/06/10-07/23/10	5
Cot on the Web	2333 Buchanan #A	09/01/11-02/15/12	1

Upon visiting these businesses during the course of investigating complaints, staff found that the primary activity of the patrons at each of these locations is playing a sweepstakes game, which resembles video slot machines. A copy of the "Sweepstakes Rules" from the Cot on the Web is attached (Attachment "H"). Concerns were raised that the on-going "sweepstakes games" appeared to be potentially illegal gambling; although, that is not the focus of the action before the City Council.

Ms. Simmons, the owner of T's Internet Café (now closed) and Cot on the Web has stated that her business sells internet time and also runs a sweepstakes as a promotional tool to draw customers. The customer receives a number of sweepstakes entries proportional to the amount of internet time purchased. The customer then plays the sweepstakes entries on the computer via an interface that resembles a video slot machine. At Cot on the Web, the potential maximum single winnings are over \$1,000. At the Internet Room, staff was told that a maximum single winning payout could reach \$2,800.

Determination that Use was a Mechanical or Electrical Game

With rising concerns about the general health, safety, and welfare of the community, staff determined that the primary activity at these facilities was not offering internet, copy, print and fax services to small businesses, but rather a gaming business. Putting aside whether this gaming activity is illegal gambling under state law, the Community Development Director

determined that the use was more properly classified as a Mechanical or Electronic Game, pursuant to Municipal Code Section 9-5.3816 (Attachment "I"). Such uses are prohibited within 1000 feet of a playground or school and a use permit is required for other locations.

Once this determination was made, staff sent Notices of Violation to the existing internet café/sweepstakes businesses and did not permit T's Internet Café to relocate without first obtaining a use permit (Attachment "J"). The owners of all three businesses have appealed that determination (Attachment "K"). In part, Allan Moore, the attorney for the Internet Room, indicates that his client is engaged in internet activities protected by the First Amendment and that the California Appellate Court in *Vo v. City of Garden Grove* (115 Cal. App. 4th 425(2004)) does not allow for unfettered discretion in issuing a use permit for such a use. However, in discussions with staff, the businesses expressed a willingness to work with the City to address the concerns through appropriate regulations.

Urgency Ordinance

To adopt a regular ordinance, a first reading of the ordinance is held and then a second reading to adopt the ordinance at a regular meeting of the City Council. A regular ordinance is effective 30 days after adoption. An urgency ordinance is adopted at one meeting and takes effect immediately following a 4/5 vote of the City Council finding that there is a need for the immediate preservation of the public peace, health and safety.

It is not uncommon for a city council to adopt an urgency ordinance followed by taking the steps to adopt a regular ordinance in case there is any question about the findings for the immediate preservation of the public peace, health and safety.

Interim Ordinances/Moratoriums

An interim zoning ordinance is often called a moratorium and takes effect immediately to prohibit a use. Pursuant to Government Code Section 65858, the City may establish a moratorium prohibiting any use that may be in conflict with a contemplated general plan, specific plan, or zoning proposal that the City Council, Planning Commission or the Planning Department is considering in order to protect and preserve the public safety, health and welfare. A moratorium lasts only 45 days, but may be extended for up to a total of two (2) years, provided that the current and immediate threat to the public safety, health and welfare still exists, and the City follows the public notice and hearing procedures for extension of the moratorium. Interim ordinances require a 4/5 vote of the City Council.

In order to initiate a zoning ordinance, a Resolution of Initiation is required by the Antioch Municipal Code directing staff, and then presumably the Planning Commission, to consider whether amendments to the zoning ordinance (Title 9 of the Antioch Municipal Code) are appropriate.

DISCUSSION

Rather than continue to debate whether the existing computer gaming and internet access businesses fall within the existing Mechanical or Electronic Game Ordinance in Antioch Municipal Code Section 9-5.3816 through appeals to the Board of Administrative Appeals, staff recommends that the City Council use its regulatory police power to study and address these uses and their impacts. Staff proposes the following definition for these uses:

“Computer Gaming and Internet Access Business” shall mean an establishment that provides more than four (4) computers or other electronic devices for access to the world wide web, internet, e-mail, video games or computer software programs which operate alone or are networked (via LAN, WAN or otherwise) or which function as a client/server program, and which seeks compensation, in any form, from users. Computer Gaming and Internet Access Business is synonymous with a personal computer (“PC”) café, internet café, cyber café, sweepstakes gaming facilities, business center, internet sales business and internet center, but does not include a Public Use or Internet Learning Center as defined herein.

“Public Use or Internet Learning Center” shall mean an establishment that provides computer access which is operated by the City of Antioch, a school district, a library, a college district, or a private institution of learning which provides classes in computer instruction or a non-profit organization which does not receive compensation in any form other than school tuition.

It is presumed that the businesses would not feel compelled to continue with their appeals of the Community Development Director’s determination that their businesses fall under Mechanical or Electronic Game Ordinance in Antioch Municipal Code Section 9-5.3816, as the more specific Interim Zoning Ordinance and Urgency Ordinance will in effect supersede the application of the Mechanical or Electronic Game Ordinance making the appeals moot.

During this study period, no new computer gaming and internet access businesses could open and the existing two businesses would be required to follow the regulations set forth in the Urgency Ordinance (Attachment “B”). This approach should alleviate any concerns that the City is negatively impacting anyone’s ability to access the internet and possible First Amendment rights. During this study period, City staff can meet with the representatives of these businesses to better address the issues that have been raised.

It should also be noted that computers accessing the internet are available at no charge at the Library Annex at the Antioch Community Center at Prewett Park and at the Antioch Library located at 501 W. 18th Street.

Urgency Findings

The existing computer gaming and internet access businesses have created impacts that create immediate threats to the public peace, health or safety, as more specifically shown in the testimony provided by the Police Department including the log of the calls for service at each facility; summary showing calls for service at each location and the surrounding vicinity before and during the time the use opened; and arrests from these various locations.

Threats to public health, safety and welfare experienced in Antioch at the computer gaming and internet access businesses include criminal activity associated with robbery, illegal drug use and sales, burglary, assaults, public intoxication, vandalism, property damage and loitering. It is also known that other cities have experienced significant gang-related activities and prostitution occurring at these computer gaming and internet access businesses. Truancy and curfew violations have also been experienced in other communities.

Operation of additional computer gaming and internet access businesses will increase these negative impacts while the use is being studied. Further, additional computer gaming and internet access businesses could create conflicts among land uses or conflict with the City’s

long-term planning goals. Thus, it is recommended that the City Council also adopt a resolution initiating an Amendment to the Zoning Ordinance to formally commence the process for studying land use issues related to computer gaming and internet access businesses, including whether the uses should only be allowed in specific zoning districts, whether there should be limitations on the concentration of uses, and similar issues.

Proposed Regulations

The proposed regulations set forth in the Urgency Ordinance and Regular Ordinance to establish a licensing scheme for Computer Gaming and Internet Access Businesses and address operational issues like prohibiting minors in the business during school hours, hours of operation, establishment of an interior waiting area with seats to avoid loitering, staffing levels, surveillance system, alarm system, security guards, prohibition on private rooms and the like. Staff has already scheduled a meeting with the business operators for Monday, February 27, 2012 to address these regulations and related items. Staff will be reporting at the City Council meeting regarding the outcome of this meeting.

FISCAL IMPACT

The computer gaming and internet access businesses are causing negative impacts to the City's limited police resources, so it is prudent to address the negative impacts.

There is no direct fiscal impact with the adoption of the proposed Interim Urgency Zoning Ordinance and Urgency Ordinance, introduction of the Regular Ordinance and adoption of the Resolution Initiating a Zoning Amendment. There will be staff time expended to meet with business representatives and to finalize a Regular Ordinance and prepare a Zoning Amendment, if appropriate.

OPTIONS

1. If the Council chose not to adopt the Interim Urgency Zoning Ordinance by 4/5 vote, then additional computer gaming and internet access businesses could open without the benefit of the City further studying the impacts of these businesses and appropriate land use regulations.
2. If the Council chose not to adopt the Urgency Ordinance by 4/5 vote, then the Regular Ordinance can be introduced on a majority vote. The Regular Ordinance would require a second reading for adoption and then be effective 30 days later.
3. The Council could choose not to initiate a Resolution for a Zoning Amendment, but staff recommends that the Council start the process for staff, and potentially Planning Commission, to at least study the issue to determine if Zoning Ordinance Amendments would be appropriate for this computer gaming and internet access business use.

ATTACHMENTS

- A. Interim Urgency Zoning Ordinance prohibiting the issuance of permits, licenses or approvals for construction, establishment or operation of any computer gaming and internet access business within the City of Antioch on an interim basis pending consideration of amendments to Title 9 of the Antioch Municipal Code for a period of forty-five days and declaring the urgency thereof

- B. Urgency Ordinance amending Title 5 of the Antioch Municipal Code by adding Chapter 11 pertaining to the licensing procedures and regulations for Computer Gaming and Internet Access Businesses and making findings declaring the urgency thereof
- C. Regular Ordinance amending Title 5 of the Antioch Municipal Code by adding Chapter 11 pertaining to the licensing procedures and regulations for Computer Gaming and Internet Access Businesses
- D. Resolution to initiate an amendment to the Zoning Ordinance to address Computer Gaming and Internet Access Businesses
- E. Business License Applications for Internet Room, T's Internet Café and Cot on the Web
- F. Comparison of Calls for Service prepared by the Police Department
- G. Log of Calls for Service at the Internet Room, T's Internet Café and Cot on the Web
- H. Sweepstakes Rules from Cot on the Web
- I. Municipal Code Section 9-5.3816
- J. Determination by Community Development Director regarding uses
- K. Appeals by the Internet Room, T's Internet Café and Cot on the Web

ATTACHMENT "A"

ORDINANCE NO.

AN ORDINANCE OF THE CITY COUNCIL OF THE CITY OF ANTIOCH ADOPTING AN INTERIM URGENCY ZONING ORDINANCE PURSUANT TO CALIFORNIA GOVERNMENT CODE SECTION 65858 PROHIBITING THE ISSUANCE OF PERMITS, LICENSES OR APPROVALS FOR CONSTRUCTION, ESTABLISHMENT OR OPERATION OF COMPUTER GAMING AND INTERNET ACCESS BUSINESSES WITHIN THE CITY ON AN INTERIM BASIS PENDING CONSIDERATION OF AMENDMENTS TO TITLE 9 OF THE ANTIOCH MUNICIPAL CODE FOR A PERIOD OF FORTY-FIVE DAYS AND DECLARING THE URGENCY THEREOF

The City Council of the City of Antioch does ordain as follows:

SECTION 1. Interim Urgency Zoning Ordinance. This ordinance is adopted pursuant to the authority of Section 65858 of the Government Code of the State of California, the Antioch City Municipal Code and applicable laws.

SECTION 2. Findings. The Antioch City Council hereby finds, determines and declares as follows:

A. The City of Antioch holds the right to make and enforce all laws and regulations not in conflict with the general laws, and the City holds all rights and powers established by state law.

B. The City has received and anticipates additional requests for the construction, establishment and operation of Computer Gaming and Internet Access Businesses (as defined herein) within the City. However, the provisions of the City Municipal Code that may regulate the construction, operation and establishment of Computer Gaming and Internet Access Businesses in the City are inadequate and need review, study, and revision. The current provisions also fail to fully take into account the impacts related to the location and manner of construction, establishment and operation of Computer Gaming and Internet Access Businesses, and the related public health, safety, and welfare concerns, including but not limited to the impacts they may have on parking, surrounding uses, and the community.

C. Computer Gaming and Internet Access Businesses often have local school students and minors as their target market, and thereby may encourage the assembly of significant numbers of minors without supervision by parents or guardians. Further, given concerns about attendance at the Antioch Unified School District such congregation of students should not be allowed during regular school hours.

D. While the City's codes do regulate mechanical or electronic games, the computer stations at Computer Gaming and Internet Access Businesses are used in a manner that may be considered different from coin-operated video game machines, and therefore have different impacts. There is generally a charge for use of the computer station, and many users may occupy a particular station for multiple consecutive hours,

creating unknown impacts on the surrounding area and businesses, such as observed lines of individuals waiting to access these businesses. Some Computer Gaming and Internet Access Businesses may stage late-night gaming sessions, which may encourage violation of the City's curfew ordinance or create and promote other late-night noise and related impacts on the surrounding community. Recently there have been Computer Gaming and Internet Access Businesses that promote "sweepstakes gaming" which encourages game playing that may provide chances to be awarded prizes. The extended use of such facilities by multiple persons waiting for a limited number of computer stations could contribute to increased detrimental effects on the commercial area where located and the surrounding residential area.

E. The City Council of the City of Antioch is also concerned with the increased calls for service, increasing reports of violent criminal behavior and related detrimental neighborhood effects associated with Computer Gaming and Internet Access Businesses.

F. The City of Antioch, as well as neighboring cities, have experienced criminal activity associated with Computer Gaming and Internet Access Businesses, including incidents involving robbery, illegal drug use and sales, burglary, assaults, public intoxication, vandalism and property damage and loitering. It is also known that other cities have experienced significant gang-related activities and prostitution occurring at these Computer Gaming and Internet Access Businesses. For example, the Antioch Police Department has documented a significant increase in service related calls involving a variety of crimes in these businesses and within the neighborhoods adjacent to Computer Gaming and Internet Access Businesses and include the representational incidents below as findings as follows:

1. On April 13, 2010, there was a call for service from T's Internet Café at 1836 A Street because of a fight over someone owing someone money and on July 23, 2010 a call for service regarding another fight.
2. At T's Internet Café at 1653 A Street on September 11, 2010, there was a call for service regarding possible assault, drug violations and carjacking. On November 18, 2010, a male robbed money from the business with a sawed-off shot gun and shot at one of the workers. On February 2, 2011, there was a call for service regarding drug selling. On July 21, 2011, there was a report of a car theft and then a fight broke out.
3. At the Internet Room at 2962 Delta Fair Boulevard, on January 28, 2012, there was a report of a stolen vehicle.
4. At T's Internet Café at 1908 A Street on August 20, 2011, someone was throwing things at the business and threatening to harm the employees.
5. While at Computer Gaming and Internet Access Businesses in Antioch, individuals have been arrested for robbery, narcotics violations, carjacking and other crimes, as well as on outstanding warrants. While some of

these crimes may have occurred elsewhere, it does show a propensity for individuals who engage in criminal activity to patronize Computer Gaming and Internet Access Businesses.

6. At 2962 Delta Fair Boulevard, calls for service have increased at that location and at neighboring businesses as much as 450% since the Internet Room started operating.
7. At 1836 A Street, before T's Internet Café opened there were 157 calls for service from that location and neighboring businesses over a 7-month period from February 1, 2009 through August 30, 2009. While T's Internet Café was operating at 1836 A Street, calls for service increased to 240 (a 52% increase) over a 7-month period from February 1, 2010 through August 30, 2010. When T's Internet Café closed at that location, calls for service from that location and neighboring businesses went back down to 158 calls for service over the 7-month period from February 1, 2011 through August 30, 2011, almost identical to the rates before T's Internet Café opened.

G. Without the enactment of this Ordinance, multiple applicants could quickly receive entitlements which would allow additional Computer Gaming and Internet Access Businesses that pose a threat to the public health, safety, and welfare. The City Council hereby determines that the Municipal Code is in need of updating to protect the public against health, safety, and welfare dangers caused by Computer Gaming and Internet Access Businesses. The City requires additional time to prepare, evaluate and adopt reasonable regulations regarding the construction, placement and operation of Computer Gaming and Internet Access Businesses so that such regulations are applied in a nondiscriminatory manner.

H. In order to prevent the frustration of these studies and the implementation of new regulations, the public interest, health, safety, and welfare require immediate enactment of this Ordinance. The absence of this Ordinance would impair the orderly and effective implementation of contemplated Municipal Code amendments, and any further authorization of these uses within the City during the period of the interim zoning regulations may be in conflict with or may frustrate the contemplated updates and revisions of the Municipal Code.

I. Based on the foregoing, the City finds that there is a current and immediate threat to the public health, safety, or welfare and that this Ordinance is necessary in order to protect the City from the potential effects and impacts of Computer Gaming and Internet Access Businesses in the City, potential increases in crime, impacts on parking availability in the business areas of the City, the aesthetic impacts to the City, and other similar or related effects on property values and the quality of life in the City's neighborhoods.

J. The City Council further finds that this interim zoning regulation is a matter of local and City-wide importance and is not directed towards any particular business that

currently seeks to construct or operate a Computer Gaming and Internet Access Business.

K. The City Council finds that this Ordinance is authorized by the City's police powers. The City Council further finds that the length of the interim zoning regulations imposed by this Ordinance will not in any way deprive any person of rights granted by state or federal laws, because the interim zoning regulation is short in duration and essential to protect the public health, safety and welfare.

SECTION 3. Interim Regulations. The following provisions are hereby adopted as interim zoning standards pertaining to the review or approval of any entitlements or the issuance of any permits or licenses pursuant to the Antioch Municipal Code for Computer Gaming and Internet Access Businesses. The approval of any entitlements or the issuance of any permit or license in the City in conflict with these provisions is expressly prohibited:

A. **Restricted Activities.** For a period of forty-five (45) days following the enactment of this Ordinance, no person shall be issued a permit, license or land use entitlement for the construction, placement, or operation of new Computer Gaming and Internet Access Businesses within the City. The City Manager or his or her designee shall review any application for a permit, license or land use entitlement to determine applicability of the provisions of this Ordinance. City Staff, City boards and City commissions are directed to refrain from issuing any application for any permits, licenses or land use entitlement, including, but not limited to, use permits, variances, building permits, licenses and certificates of occupancy, necessary for construction, placement, or operation of a Computer Gaming and Internet Access Business. These prohibitions shall remain in effect during the forty-five (45) days following enactment of this Ordinance. The two existing Computer Gaming and Internet Access Businesses may continue to operate at their current locations: Internet Room at 2962 Delta Fair Boulevard and Cot on the Web at 2333 Buchanan Road.

B. **Definitions.** In addition to the definitions contained in the City's Municipal Code, the following words and phrases shall, for the purposes of this Ordinance, be defined as follows, unless it is clearly apparent from the context that another meaning is intended. Should any of the definitions be in conflict with the current provisions of the Municipal Code, the following definitions shall prevail:

1. "Computer Gaming and Internet Access Business" shall mean an establishment that provides more than four (4) computers or other electronic devices for access to the world wide web, internet, e-mail, video games or computer software programs which operate alone or are networked (via LAN, WAN or otherwise) or which function as a client/server program, and which seeks compensation, in any form, from

users. Computer Gaming and Internet Access Business is synonymous with a personal computer ("PC") café, internet café, cyber café, sweepstakes gaming facilities, business center, internet sales business and internet center, but does not include a Public Use or Internet Learning Center as defined herein.

2. "Public Use or Internet Learning Center" shall mean an establishment that provides computer access which is operated by the City of Antioch, a school district, a library, a college district, or a private institution of learning which provides classes in computer instruction or a non-profit organization which does not receive compensation in any form other than school tuition.

SECTION 4. CEQA. This ordinance is not a project within the meaning of Section 15378 of the State CEQA (California Environmental Quality Act) Guidelines, because it has no potential for resulting in physical change in the environment, directly or ultimately. In the event that this Ordinance is found to be a project under CEQA, it is subject to the CEQA exemption contained in CEQA Guideline section 16061 (b) (3) because it can be seen with certainty to have no possibility of a significant effect on the environment.

SECTION 5. Severability. If any section, subsection, subdivision, sentence, clause, phrase, or portion of this Ordinance is, for any reason, held to be invalid or unconstitutional by the decision of any court of competent jurisdiction, such decision shall not affect the validity of the remaining portions of this Ordinance. The City Council hereby declares that it would have adopted this Ordinance, and each section, subsection, subdivision, sentence, clause, phrase, or portion thereof, irrespective of the fact that any one or more sections, subsections, subdivisions, sentences, clauses, phrases, or portions thereof be declared invalid or unconstitutional.

SECTION 6. Effective Date. This interim ordinance shall take effect immediately upon its adoption and shall continue in effect for forty-five (45) days from the date of its adoption by not less than a four-fifth's vote of the Antioch City Council, and shall thereafter be of no further force and effect, unless, after notice pursuant to Government Code Section 65090 and public hearing, the Antioch City Council extends this Ordinance, and the interim zoning regulations adopted thereby, pursuant to Government Code Section 65858.

SECTION 7. Report of Council. Ten days prior to the expiration of this Ordinance, or any extension thereof, this Council shall issue a written report describing the measures taken to alleviate the condition which led to the adoption of this ordinance, or any extension thereof.

SECTION 8. Declaration of Urgency. This ordinance is hereby declared to be an urgency measure necessary for the immediate protection of the public health, safety and welfare. This Council hereby finds that there is a current and immediate threat to

the public health, safety and welfare. The reasons for this urgency are declared and set forth in Section 2 of this Ordinance and are incorporated herein by reference.

SECTION 9. Publication; Certification. The City Clerk shall certify to the adoption of this Ordinance and cause same to be published in accordance with State law.

* * * * *

I HEREBY CERTIFY that the foregoing Ordinance was introduced and adopted as an urgency ordinance pursuant to the terms of California Government Code Section 65858 at a regular meeting of the City Council of the City of Antioch on the 28th day of February, 2012, by the following vote:

AYES:

NOES:

ABSENT:

ABSTAIN:

James D. Davis, Mayor of the City of Antioch

ATTEST:

Denise Skaggs, City Clerk of the City of Antioch

ATTACHMENT "B"

ORDINANCE NO.

AN URGENCY ORDINANCE OF THE CITY COUNCIL OF THE CITY OF ANTIOCH AMENDING TITLE 5 OF THE ANTIOCH MUNICIPAL CODE BY ADDING A NEW CHAPTER 11 PERTAINING TO THE LICENSING PROCEDURES AND REGULATIONS FOR COMPUTER GAMING AND INTERNET ACCESS BUSINESSES AND MAKING FINDINGS DECLARING THE URGENCY THEREOF

The City Council of the City of Antioch does ordain as follows:

SECTION 1. The City Council finds as follows:

A. The City Council of the City of Antioch is concerned with the increasing reports of violent criminal behavior and related detrimental neighborhood effects associated with Computer Gaming and Internet Access Businesses.

B. The City of Antioch, as well as neighboring cities, have experienced criminal activity associated with Computer Gaming and Internet Access Businesses, including incidents involving robbery, illegal drug use and sales, burglary, assaults, public intoxication, vandalism and property damage and loitering. It is also known that other cities have experienced significant gang-related activities and prostitution occurring at these Computer Gaming and Internet Access Businesses. For example, the Antioch Police Department has documented a significant increase in service related calls involving a variety of crimes in these businesses and within the neighborhoods adjacent to Computer Gaming and Internet Access Businesses and include the representational incidents below as findings as follows:

1. On April 13, 2010, there was a call for service from T's Internet Café at 1836 A Street because of a fight over someone owing someone money and on July 23, 2010 a call for service regarding another fight.
2. At T's Internet Café at 1653 A Street on September 11, 2010, there was a call for service regarding possible assault, drug violations and carjacking. On November 18, 2010, a male robbed money from the business with a sawed-off shot gun and shot at one of the workers. On February 2, 2011, there was a call for service regarding drug selling. On July 21, 2011, there was a report of a car theft and then a fight broke out.
3. At the Internet Room at 2962 Delta Fair Boulevard, on January 28, 2012, there was a report of a stolen vehicle.
4. At T's Internet Café at 1908 A Street on August 20, 2011, someone was throwing things at the business and threatening to harm the employees.
5. While at Computer Gaming and Internet Access Businesses in Antioch, individuals have been arrested for robbery, narcotics violations, carjacking

and other crimes, as well as on outstanding warrants. While some of these crimes may have occurred elsewhere, it does show a propensity for individuals who engage in criminal activity to patronize Computer Gaming and Internet Access Businesses.

6. At 2962 Delta Fair Boulevard, calls for service have increased at that location and at neighboring businesses as much as 450% since the Internet Room started operating.
7. At 1836 A Street, before T's Internet Café opened there were 157 calls for service from that location and neighboring businesses over a 7-month period from February 1, 2009 through August 30, 2009. While T's Internet Café was operating at 1836 A Street, calls for service increased to 240 (a 52% increase) over a 7-month period from February 1, 2010 through August 30, 2010. When T's Internet Café closed at that location, calls for service from that location and neighboring businesses went back down to 158 calls for service over the 7-month period from February 1, 2011 through August 30, 2011, almost identical to the rates before T's Internet Café opened.

C. Computer Gaming and Internet Access Businesses often have local school students and minors as their target market, and thereby may encourage the assembly of significant numbers of minors without supervision by parents or guardians. Further, given concerns about attendance at the Antioch Unified School District such congregation of students should not be allowed during regular school hours.

D. The City Council of the City of Antioch finds that the activities of Computer Gaming and Internet Access Businesses have become frequently associated with detrimental impacts to the surrounding area.

E. The Antioch Municipal Code does not currently provide adequate standards and regulations concerning the review, approval and operation of Computer Gaming and Internet Access Businesses. Section 9-5.3816 pertaining to Mechanical or Electronic Games is at least 30 years old and does not specifically address regulations pertinent to Computer Gaming and Internet Access Businesses.

F. The City Council finds, determines and declares that the current threat to the public health, safety and welfare of the City and its citizens necessitates the immediate enactment of this Ordinance to help deter and prevent crimes and criminal activity from occurring at and around Computer Gaming and Internet Access Businesses.

G. The City Council further finds that this Ordinance constitutes a matter of Citywide importance and is not directed towards nor targeted at any particular parcel of property, any particular business or any proposed occupant.

SECTION 2. Title 5 of the Antioch Municipal Code is hereby amended by the addition of a new Chapter 11, to read as follows:

“Chapter 11”

COMPUTER GAMING AND INTERNET ACCESS BUSINESSES

Sections:

<u>5-11.01</u>	Purpose.
<u>5-11.02</u>	Definitions.
<u>5-11.10</u>	Computer Gaming and Internet Access Business - License required.
<u>5-11.11</u>	Term of license.
<u>5-11.12</u>	Renewal of license.
<u>5-11.20</u>	License application and issuance.
<u>5-11.30</u>	Transfer of license.
<u>5-11.40</u>	Alterations to Computer Gaming and Internet Access Business.
<u>5-11.50</u>	License revocation.
<u>5-11.60</u>	Operational standards and regulations.
<u>5-11.70</u>	Abatement of nuisance.
<u>5-11.80</u>	Penalty.
<u>5-11.90</u>	License fees.

§ 5-11.01 Purpose.

It is the purpose and intent of this chapter to regulate Computer Gaming and Internet Access Businesses to promote the protection of the public from the dangers of fire and hazards to health, to ensure the full protection of minors, and for the general preservation of the peace and welfare of the community. It is the intent of the City to establish minimally intrusive protocols to provide reasonable accountability for computer gaming and internet access and use at Computer Gaming and Internet Access Businesses. The City finds such accountability to be reasonably necessary to minimize the risk of use of the computer and/or internet by persons at Computer Gaming and Internet Access Businesses for criminal purposes and to increase the opportunities for the safe apprehension of such persons patronizing Computer Gaming and Internet Businesses for criminal purposes, while recognizing rights of individuals to use the internet and Computer Gaming and Internet Access Businesses for legitimate purposes.

§ 5-11.02 Definitions.

A. “Computer Gaming and Internet Access Business” shall mean an establishment that provides more than four (4) computers or other electronic devices for access to the world wide web, internet, e-mail, video games or computer software programs which operate alone or are networked (via LAN, WAN or otherwise) or which function as a client/server program, and which seeks compensation, in any form, from users. Computer Gaming and Internet Access Business is synonymous with a personal computer (“PC”) café, internet café,

cyber café, sweepstakes gaming facilities, business center, internet sales business and internet center, but does not include a Public Use or Internet Learning Center as defined herein.

B. "Public Use or Internet Learning Business" shall mean an establishment that provides computer access which is operated by the City of Antioch, a school district, a library, a college district, or a private institution of learning which provides classes in computer instruction or a non-profit organization which does not receive compensation in any form other than school tuition.

§ 5-11.10 Computer Gaming and Internet Access Businesses - License required.

It is unlawful for any person to engage in, conduct or carry on, in or upon any premises or real property located within the City, the activities of an Computer Gaming and Internet Access Business, unless such person has been granted a valid license pursuant to the provisions of this chapter. A separate license shall be required for each location within the City where a Computer Gaming and Internet Access Business is to be established. Public Use or Internet Learning Business shall be exempt from the license requirements herein.

§ 5-11.11 Term of license.

The term of a Computer Gaming and Internet Access Business license, unless sooner suspended or revoked, shall be one year.

§ 5-11.12 Renewal of license.

A Computer Gaming and Internet Access Business license, issued pursuant to the provisions of this chapter, that has not been suspended or revoked, may be renewed, upon payment of the renewal application fee, for a period not to exceed one year upon written application to the Community Development Director made at least sixty (60) days prior to the expiration date of the current valid license. This application for renewal of a license shall contain all of the information required by Section § 5-11.120 of this chapter and shall be processed in accordance with the provisions of this chapter.

§ 5-11.20 License application and issuance.

A. Any person desiring to obtain a license or to renew an existing license to operate a Computer Gaming and Internet Access Business shall file a written application with the Community Development Director. The application shall be signed under the penalty of perjury. Prior to submitting the application, a nonrefundable fee, in an amount established by resolution of the City Council, shall be paid to the City to defray the cost of the investigation and issuance

required by this chapter. The license issuance or renewal fee required under this chapter shall be in addition to any other license or fee required under this code.

B. Neither the filing of an application for a license or renewal thereof nor payment of an application or renewal fee shall authorize the operation of a Computer Gaming and Internet Access Business until such license has been granted or renewed.

C. Each applicant for a Computer Gaming and Internet Access Business license or renewal thereof shall furnish the following information:

1. The present or proposed address where the business is to be conducted;
2. The full and true name under which the business will be conducted;
3. The full and true name and any other names used by the applicant and owner of the business, if the owner is not the applicant;
4. The applicant and owner's present residential and business addresses and telephone numbers;
5. Each residential and business address of the applicant and the owner for the five-year period immediately preceding the date of filing the application and the inclusive dates of each address;
6. The California driver's license or identification number of the applicant and owner;
7. A precise description of the activities and/or services to be provided;
8. A detailed site and floor plan of the proposed business, depicting the building and unit proposed and including interior dimensions and off-street parking spaces required by the City's zoning code;
9. A detailed description of the food and beverage service, if any, that will be offered to patrons;
10. The dates and hours during which the Computer Gaming and Internet Access Business is desired to be conducted and a list of the fees to be charged patrons;

11. The name(s) of the person(s) responsible for the operation, management, and supervision of the Computer Gaming and Internet Access Business;

12. A statement as to whether the applicant, owner, or any person to be responsible for the operation, management, and supervision of the Computer Gaming and Internet Access Business has, within the past five (5) years, had any permit or license issued in conjunction with a Computer Gaming and Internet Access Business in any jurisdiction, and whether during that period the license was suspended or revoked. If so, then the application shall provide the name of the issuing agency and an explanation of the suspension or revocation;

13. Signature of the property owner indicating approval of the submission of the license application; and

14. Such other information as the Community Development Director may require to discover the truth of the matters required to be set forth in the application.

D. The applicant shall present proof to the Community Development Director that the required application or application renewal fee has been paid, and shall present the application containing the information and supporting documentation required by subsection C of this section. A copy of the application shall be distributed to the City's Planning and Building Divisions, the Police Department and the Fire District for review.

E. When any change occurs regarding the written information required by subsection C of this section to be included in the application, the applicant or license holder, as the case may be, shall give written notification of such change to the Community Development Director within five (5) business days of such change.

F. The Community Development Director shall have a reasonable time, not to exceed thirty (30) days to investigate the facts set forth in the application and to receive comments from the City's Planning and Building Departments, the Police Department and the Fire District. The Community Development Director shall, within sixty (60) days after the date of the filing of the application, grant the license or renewal thereof only if it is found that all of the following requirements have been met:

1. The required fees have been paid;
2. The application and all information contained therein conform in all respects to the provisions of this chapter;
3. The applicant has not knowingly made a material misrepresentation of fact in the application;

4. The proposed Computer Gaming and Internet Access Business would comply with this chapter and all other applicable city, county and state laws including, but not limited to, health, zoning, fire and safety requirements and standards, and that, as proposed, the Computer Gaming and Internet Access Business would not tend to generate criminal activities, present unnecessary criminal opportunities, or tend to cause violations of curfews by minors due to failure to comply with Federal or State law or the Municipal Code including but not limited to Operational Standards set forth below ;

5. The applicant is at least eighteen (18) years of age;

6. The Computer Gaming and Internet Access Business site and floor plan have been reviewed by the City's Planning and Building Departments and the Police Department and Fire District, which have approved the same as well as all fire and panic safety equipment required to be installed; all requirements of the Americans with Disabilities Act have been satisfied; and that the maximum occupancy has been established, will be posted and will not likely be exceeded based on the floor plan; and,

7. The Community Development Director has not received evidence that the applicant has, within the previous five (5) years, had any license or entitlement to operate a Computer Gaming and Internet Access Business revoked due to the applicant's commission of a crime or violation of the operational standards or conditions of approval applicable to a Computer Gaming and Internet Access Business; provided, however, a Computer Gaming and Internet Access Business license may be granted subject to additional conditions designed to preclude a recurrence of the events or activities causing the prior license revocation.

G. If the Community Development Director does not find that all of the requirements of subsection F of this section have been met, the application shall be denied.

1. In the event that an application for a license or renewal thereof is denied, written notice of the denial shall be given to the applicant within sixty (60) days after the date of the filing of the application specifying the ground(s) of the denial and a description of the hearing rights provided by Section § 5-11.20(G)()2, below. Notice of denial of the application may be personally served or served by first-class postage prepaid and addressed to the applicant at the address set forth in the application. Mailed notice shall be deemed received three (3) days after mailing.

2. The decision of the Community Development Director may be appealed by filing a written notice requesting a hearing within ten (10) calendar days of the decision of the Community Development Director. The appeal may be heard by a Hearing Officer (for purposes of this section, the term Hearing

Officer shall mean the City Manager or a Hearing Officer appointed by the City Manager) or by the Board of Administrative Appeals, pursuant to Chapter 4 of Title 1 of the Municipal Code.

a. The hearing shall be conducted within forty-five (45) days of the request.

b. The hearing shall be conducted under such rules of procedure as are appropriate to quasi-judicial proceedings, provided that the applicant and the City shall be entitled to present relevant evidence, testify under oath, and call witnesses who shall testify under oath. The Hearing Officer/Board of Administrative Appeals shall not be bound by the statutory rules of evidence in the hearing. The applicant shall have the burden of proof that the Community Development Director's determination was wrong. The hearing shall be recorded so that a transcript of the hearing can be prepared by either party.

c. At the conclusion of the hearing, the Hearing Officer/Board of Administrative Appeals shall decide whether the grounds for denial, revocation or non-renewal exist. Within ten (10) days after the conclusion of the hearing, the Hearing Officer/Board of Administrative Appeals shall file with the City Clerk, together with the recording of the hearing, a written decision supported by written findings based on the evidence submitted and a statement of the order. A copy of the decision shall be forwarded by certified mail, postage prepaid, to the applicant by the City Clerk. The decision of the Hearing Officer/Board of Administrative Appeals shall become effective three (3) days after its mailing to the applicant unless timely appealed as provided in the following Section.

H. The decision of the Hearing Officer or Board of Administrative Appeals shall be final unless appealed to the City Council by the filing of a written appeal with the City Clerk by the City Manager or member of the Council within ten (10) calendar days of mailing of the decision. All such appeals shall be filed with the City Clerk and shall be public records. The City Council shall, at a duly noticed meeting within forty-five (45) days from the date the written appeal was filed, independently review the entire record, including the recording or transcript of the hearing and any oral or written arguments which may be offered to the City Council by the appellant. At the conclusion of the review, a majority of the City Council members present may decide to sustain the decision, modify the decision, or order the decision stricken and issue such order as the City Council finds is supported by the entire record. The lack of a majority to take action means that the decision of the Hearing Officer or Board of Administrative Appeals remains in effect. The action of the City Council shall be final and conclusive, shall be rendered in writing within ten days, and shall be immediately mailed or delivered to the applicant.

I. Notwithstanding any provisions in this chapter regarding the occurrence of any action within a specified period of time, the applicant may

request additional time beyond that provided or may request a continuance regarding any decision or consideration by the City of the pending appeal. Extensions of time sought by applicants shall not be considered delay on the part of the City or constitute failure by the City to provide for prompt decisions on applications.

J. The time for a court challenge to a decision under this section is governed by California Code of Civil Procedure § 1094.8 and notice of the City's decision and its findings shall include citation to California Code of Civil Procedure § 1094.8.

§ 5-11.30 Transfer of license.

Unless prior application is made, thereafter approved, and a license issued thereon, upon the sale or transfer of any interest in a Computer Gaming and Internet Access Business, the license shall immediately become null and void. A new application must be made and a new fee paid by any person desiring to own or operate the Computer Gaming and Internet Access Business. Any application involving the sale or transfer of any interest in an existing Computer Gaming and Internet Access Business, as well as any license which may thereafter be granted, shall be subject to the provisions of this chapter.

§ 5-11.40 Alterations to Computer Gaming and Internet Access Businesses.

A. A holder of a valid Computer Gaming and Internet Access Business license shall notify the Community Development Director, in writing, of any proposed change in the business location, floor plan or business name at least thirty (30) days prior to such change.

B. Nothing in this section shall excuse the owner of a Computer Gaming and Internet Access Business from obtaining all other approvals necessary to change a location, floor plan or business name, including but not limited to building permits.

§ 5-11.50 License revocation.

A. If the City finds that any person holding an Computer Gaming and Internet Access Business license has violated or allowed the violation of any of the provisions of this chapter or has conducted business in a manner that could have been grounds for license denial, the license may be revoked following notice and a hearing.

B. No revocation shall become effective until the license holder has been notified in writing of the right to a hearing pursuant to the provisions of section § 5-11.20(G) of this chapter. Notice of the pending revocation and right

to appeal shall be given to the license holder either by personal delivery or registered mail, addressed to the license holder at the address set forth in the license application. Mailed notice shall be deemed received three (3) days after mailing.

C. If a request for hearing is filed within ten (10) calendar days from the notice provided in B above, the City shall conduct an appeal hearing as provided in section § 5-11.20(G) H, I and J, above. The revocation shall be stayed pending the decision, unless, in the determination of the City Manager, immediate suspension pending the hearing is necessary due to an immediate threat to the public health, safety or welfare. Otherwise, the revocation shall become effective upon expiration of the appeal period.

§ 5-11.60 Operational standards and regulations.

A. Prohibitions regarding Minors.

1. Minors (under 18 years of age), unless legally emancipated, shall not be permitted to enter or remain in a Computer Gaming and Internet Access Business during any time that he or she is required to be in attendance at school unless accompanied by a parent or legal guardian.

2. Minors (under 18 years of age), unless legally emancipated, shall not be permitted to enter or remain in a Computer Gaming and Internet Access Business during the hours of the Juvenile Protection Curfew of 11:01 p.m. through 5:00 a.m. seven nights a week, pursuant to Article 2 of Chapter 10 of Title 5 of the Antioch Municipal Code.

3. Signs shall be placed at the entrance of the business and inside the business setting forth these restrictions in lettering of at least two (2) inches in size.

B. Hours of Operation. The Computer Gaming and Internet Access Business shall not be open to customers, patrons or any member of the public between the hours of 12:00 a.m. and 8:00 a.m. on Friday, Saturday and Sunday or between the hours of 11:00 p.m. and 8:00 a.m. Monday through Thursday.

C. Interior Waiting Area. An interior waiting area with not less than eight (8) seats shall be provided for customers waiting to use a computer. The number of seats shall be increased by one (1) for every five (5) additional computers beyond twenty-five (25) computers in the business. No outside waiting or seating area is permitted.

D. No Smoking or Consumption of Alcoholic Beverages. No person shall be permitted to smoke or consume alcoholic beverages on the inside of the

premises. The sale of cigarettes and alcohol on the premises is prohibited. No intoxicated or disorderly person shall be allowed to remain on the premises.

E. Staffing. Employees shall be at least 18 years of age. There shall be a minimum of two (2) employees staffing the Computer Gaming and Internet Access Business during all working hours with at least one manager or supervisor. The ratio of employees to computers and/or other electronic devices that access the internet shall be 2:15. During each employee's working hours, the employee shall wear a badge identifying the business and the employee's full name. Security personnel indicated in Section I below shall not be included in this minimum staffing number

F. Occupancy. Occupancy shall not exceed that required under the Uniform Building Code and Uniform Fire Code. The maximum occupancy load shall be posted at the main entrance.

G. Surveillance System.

1. The Chief of Police may require a Computer Gaming and Internet Access Business operator to install a digital camera/video surveillance system on the premises in the event there are or have been repeated calls for police services relating to the premises including, but not limited to, assaults, public intoxication, vandalism, gang activity, weapons offenses, disturbances of the peace and juvenile crimes including truancy.

2. In the event of such a determination, the establishment shall maintain and operate a camera/video surveillance system during all business hours. The system shall cover the entire interior of the premises and all entrances to and exits from the establishment. Tapes/disks shall be kept a minimum of fourteen (14) calendar days, or as required by the Chief of Police. The owner shall permit a representative of the Police Department's office to inspect the tapes/disks during business hours.

3. A sign shall be posted inside and at the entrances to the establishment indicating that the premises are under camera/video surveillance.

H. Window Coverings. Window areas shall not be covered, tinted or made opaque in any way, or obscured in any way by landscaping, floor displays, equipment or the like, excepting during daylight hours when partial blinds or other equivalent window coverings may be used as long as the interior remains visible from the public right of way.

I. Security Guards.

1. The Chief of Police may require a specific Computer Gaming and Internet Access Business operator to provide a security guard(s) on the premises

in the event there are repeated calls for police services relating to the premises including, but not limited to, assaults, gang activity, weapons offenses, disturbances of the peace and juvenile crimes including truancy.

2. The security guard shall be uniformed and be employed by a Private Patrol Operator that is currently licensed with the California Department of Consumer Affairs. The name of the Patrol Operator with state license number and the guard registration numbers shall be provided to the Community Development Department. Any changes to the Patrol Operator shall be approved by the Police Chief at least two working days prior to Patrol Operator taking over security at the business.

3. The security guard shall also patrol the exterior of the business and any parking lot areas.

4. The Chief of Police may require more than one security guard if there are more than fifteen (15) computers or similar devices or continued repeated calls for service indicate that one security guard is not adequate.

J. No Adult Entertainment Business or Adult Boutique. Any access to adult entertainment oriented web sites, as defined in section 9-5.203 of this code, is prohibited unless specifically permitted under sections 9-5.3808 or 9-5.3808.1 of this code.

K. No Other Amusement Devices. No pool tables or other amusement devices not directly related to the internet and similar computer devices shall be permitted in the business.

L. No Tournaments. No gaming tournaments for cash prizes deemed to be gambling under the provisions of State Law shall be permitted.

M. Interior Signs. User rates and other fees must be conspicuously posted on the premises.

N. No Illegal Gambling. Under no circumstances shall electronic game machines, which include computers and other amusement devices, be used for illegal gaming or gambling. The applicant shall be responsible for ensuring customers do not use any electronic game machine for illegal gaming or gambling.

O. No Litter. The applicant shall provide adequate trash receptacles both inside and outside of the building. The applicant shall keep the outside of the business, including the parking lot, free of litter, trash and debris.

P. No Private Booths. Any booth or individual computer use area within the business shall be visible from a continuous and accessible main aisle

in a public portion of the Computer Gaming and Internet Access Business, and shall not be obscured by any door, curtain, wall, two-way mirror or other device which would prohibit a person from seeing the entire interior of the booth/individual viewing area from the main aisle. Further, no one shall maintain any booth/individual viewing area in any configuration unless the entire interior wherein the computer that is being used is visible from one main aisle. No doors are permitted on a booth/individual viewing area. No partially or fully enclosed booth/individual viewing areas or partially or fully concealed booth/individual viewing areas shall be maintained.

Q. Alarm System. The Chief of Police may require a specific Computer Gaming and Internet Access Business operator to install an alarm system that distinguishes between a burglary and a robbery. The system shall monitor twenty-four hours per day. All public entrance and exit doors to the business shall have electronic monitoring system that produce a sound when a person transverses the doorway. If required by the Chief of Police, the system shall be electronically connected with the Police Department if activated.

R. Number of Computers. The number of computers or similar devices in a Computer Gaming and Internet Access Business shall not exceed thirty square feet of floor area per computer of the floor area that is dedicated to the placement of computers for rent or charge.

§ 5-11.70 Abatement of nuisance.

Any Computer Gaming and Internet Access Business operated, conducted or maintained contrary to the provisions of this chapter shall be and hereby is declared to be unlawful and a public nuisance, and the City may, in addition to or in lieu of any other remedy, commence an action or proceeding for the abatement, removal or enjoyment thereof, and may take such other steps and may apply to such court or courts as may have jurisdiction to grant such relief to abate or remove such establishment and restrain and enjoin any person from operating, conducting or maintaining a Computer Gaming and Internet Access Business contrary to the provisions of this chapter.

§ 5-11.90 Penalty.

It shall be unlawful for any person to violate any provision or to fail to comply with any of the requirements of this chapter. Any person violating, permitting or causing the violation of this chapter shall be deemed guilty of a misdemeanor and upon conviction thereof shall be punished as set forth in chapter 1-2.01 of this code, or any successor provision thereto. Each person shall be deemed guilty of a separate offense for each and every day, or any portion thereof, during which any violation of any provision of this chapter is committed, continued or permitted by such person and shall be deemed punishable therefore as provided in this section.

§ 5-11.90 License fees.

The City Council shall, by resolution, set a fee for application for a Computer Gaming and Internet Access Business license. Until such fee is set, the application fee shall be the minimum fee currently established for the application extension fee in the City's Master Fee Schedule."

SECTION 3. Compliance for Existing Business; Time. It is the desire and intent of the City Council that any and all existing and legal Computer Gaming and Internet Access Businesses come into compliance with the terms of this Ordinance as rapidly as possible and that all applications, review and decisions be processed on an expedited basis. Within fourteen (14) calendar days of the effective date of this ordinance, every existing Computer Gaming and Internet Access Business shall file a statement with the Community Development Director evidencing its compliance with all provisions of this chapter and providing all information as provided in § 5-11.40. The review and determination of the Community Development Director shall be provided within fourteen (14) days of the filing of the application. In the event that the license requires the installation of improvements at the business (e.g., lighting, surveillance, etc) all such improvements shall be installed per a schedule agreed to by the Community Development Director; however, not to exceed twenty-one (21) days following the determination of the Community Development Director on the license application.

SECTION 4. CEQA. This ordinance is not a project within the meaning of Section 15378 of the State CEQA (California Environmental Quality Act) Guidelines, because it has no potential for resulting in physical change in the environment, directly or ultimately. In the event that this Ordinance is found to be a project under CEQA, it is subject to the CEQA exemption contained in CEQA Guideline section 16061 (b) (3) because it can be seen with certainty to have no possibility of a significant effect on the environment.

SECTION 5. Severability. If any section, subsection, subdivision, sentence, clause, phrase, or portion of this Ordinance is, for any reason, held to be invalid or unconstitutional by the decision of any court of competent jurisdiction, such decision shall not affect the validity of the remaining portions of this Ordinance. The City Council hereby declares that it would have adopted this Ordinance, and each section, subsection, subdivision, sentence, clause, phrase, or portion thereof, irrespective of the fact that any one or more sections, subsections, subdivisions, sentences, clauses, phrases, or portions thereof be declared invalid or unconstitutional.

SECTION 6. Effective Date. This Ordinance is hereby declared an urgency measure pursuant to the terms of California Government Code section 36937 (b) and shall be effective immediately upon adoption by a four-fifths (4/5th) vote of the City Council.

SECTION 7. Publication; Certification. The City Clerk shall certify to the adoption of this Ordinance and cause same to be published in accordance with State law.

* * * * *

I HEREBY CERTIFY that the foregoing Ordinance was introduced and adopted as an urgency ordinance pursuant to the terms of California Government Code Section 36937 (b) at a regular meeting of the City Council of the City of City of Antioch on the 28th day of February, 2012, by the following vote:

AYES:

NOES:

ABSENT:

ABSTAIN:

James D. Davis, Mayor of the City of Antioch

ATTEST:

Denise Skaggs, City Clerk of the City of Antioch

ATTACHMENT "C"

ORDINANCE NO.

AN ORDINANCE OF THE CITY COUNCIL OF THE CITY OF ANTIOCH AMENDING TITLE 5 OF THE ANTIOCH MUNICIPAL CODE BY ADDING A NEW CHAPTER 11 PERTAINING TO THE LICENSING PROCEDURES AND REGULATIONS FOR COMPUTER GAMING AND INTERNET ACCESS BUSINESSES

The City Council of the City of Antioch does ordain as follows:

SECTION 1. The City Council finds as follows:

A. The City Council of the City of Antioch is concerned with the increasing reports of violent criminal behavior and related detrimental neighborhood effects associated with Computer Gaming and Internet Access Businesses.

B. The City of Antioch, as well as neighboring cities, have experienced criminal activity associated with Computer Gaming and Internet Access Businesses, including incidents involving robbery, illegal drug use and sales, burglary, assaults, public intoxication, vandalism and property damage and loitering. It is also known that other cities have experienced significant gang-related activities and prostitution occurring at these Computer Gaming and Internet Access Businesses. For example, the Antioch Police Department has documented a significant increase in service related calls involving a variety of crimes in these businesses and within the neighborhoods adjacent to Computer Gaming and Internet Access Businesses and include the representational incidents below as findings as follows:

1. On April 13, 2010, there was a call for service from T's Internet Café at 1836 A Street because of a fight over someone owing someone money and on July 23, 2010 a call for service regarding another fight.
2. At T's Internet Café at 1653 A Street on September 11, 2010, there was a call for service regarding possible assault, drug violations and carjacking. On November 18, 2010, a male robbed money from the business with a sawed-off shot gun and shot at one of the workers. On February 2, 2011, there was a call for service regarding drug selling. On July 21, 2011, there was a report of a car theft and then a fight broke out.
3. At the Internet Room at 2962 Delta Fair Boulevard, on January 28, 2012, there was a report of a stolen vehicle.
4. At T's Internet Café at 1908 A Street on August 20, 2011, someone was throwing things at the business and threatening to harm the employees.
5. While at Computer Gaming and Internet Access Businesses in Antioch, individuals have been arrested for robbery, narcotics violations, carjacking and other crimes, as well as on outstanding warrants. While some of

these crimes may have occurred elsewhere, it does show a propensity for individuals who engage in criminal activity to patronize Computer Gaming and Internet Access Businesses.

6. At 2962 Delta Fair Boulevard, calls for service have increased at that location and at neighboring businesses as much as 450% since the Internet Room started operating.
7. At 1836 A Street, before T's Internet Café opened there were 157 calls for service from that location and neighboring businesses over a 7-month period from February 1, 2009 through August 30, 2009. While T's Internet Café was operating at 1836 A Street, calls for service increased to 240 (a 52% increase) over a 7-month period from February 1, 2010 through August 30, 2010. When T's Internet Café closed at that location, calls for service from that location and neighboring businesses went back down to 158 calls for service over the 7-month period from February 1, 2011 through August 30, 2011, almost identical to the rates before T's Internet Café opened.

C. Computer Gaming and Internet Access Businesses often have local school students and minors as their target market, and thereby may encourage the assembly of significant numbers of minors without supervision by parents or guardians. Further, given concerns about attendance at the Antioch Unified School District such congregation of students should not be allowed during regular school hours.

D. The City Council of the City of Antioch finds that the activities of Computer Gaming and Internet Access Businesses have become frequently associated with detrimental impacts to the surrounding area.

E. The Antioch Municipal Code does not currently provide adequate standards and regulations concerning the review, approval and operation of Computer Gaming and Internet Access Businesses. Section 9-5.3816 pertaining to Mechanical or Electronic Games is at least 30 years old and does not specifically address regulations pertinent to Computer Gaming and Internet Access Businesses.

F. The City Council further finds that this Ordinance constitutes a matter of City-wide importance and is not directed towards nor targeted at any particular parcel of property, any particular business or any proposed occupant.

SECTION 2. Title 5 of the Antioch Municipal Code is hereby amended by the addition of a new Chapter 11, to read as follows:

“Chapter 11”

COMPUTER GAMING AND INTERNET ACCESS BUSINESSES

Sections:

<u>5-11.01</u>	Purpose.
<u>5-11.02</u>	Definitions.
<u>5-11.10</u>	Computer Gaming and Internet Access Business - License required.
<u>5-11.11</u>	Term of license.
<u>5-11.12</u>	Renewal of license.
<u>5-11.20</u>	License application and issuance.
<u>5-11.30</u>	Transfer of license.
<u>5-11.40</u>	Alterations to Computer Gaming and Internet Access Business.
<u>5-11.50</u>	License revocation.
<u>5-11.60</u>	Operational standards and regulations.
<u>5-11.70</u>	Abatement of nuisance.
<u>5-11.80</u>	Penalty.
<u>5-11.90</u>	License fees.

§ 5-11.01 Purpose.

It is the purpose and intent of this chapter to regulate Computer Gaming and Internet Access Businesses to promote the protection of the public from the dangers of fire and hazards to health, to ensure the full protection of minors, and for the general preservation of the peace and welfare of the community. It is the intent of the City to establish minimally intrusive protocols to provide reasonable accountability for computer gaming and internet access and use at Computer Gaming and Internet Access Businesses. The City finds such accountability to be reasonably necessary to minimize the risk of use of the computer and/or internet by persons at Computer Gaming and Internet Access Businesses for criminal purposes and to increase the opportunities for the safe apprehension of such persons patronizing Computer Gaming and Internet Businesses for criminal purposes, while recognizing rights of individuals to use the internet and Computer Gaming and Internet Access Businesses for legitimate purposes.

§ 5-11.02 Definitions.

A. “Computer Gaming and Internet Access Business” shall mean an establishment that provides more than four (4) computers or other electronic devices for access to the world wide web, internet, e-mail, video games or computer software programs which operate alone or are networked (via LAN, WAN or otherwise) or which function as a client/server program, and which seeks compensation, in any form, from users. Computer Gaming and Internet Access

Business is synonymous with a personal computer ("PC") café, internet café, cyber café, sweepstakes gaming facilities, business center, internet sales business and internet center, but does not include a Public Use or Internet Learning Center as defined herein.

B. "Public Use or Internet Learning Business" shall mean an establishment that provides computer access which is operated by the City of Antioch, a school district, a library, a college district, or a private institution of learning which provides classes in computer instruction or a non-profit organization which does not receive compensation in any form other than school tuition.

§ 5-11.10 Computer Gaming and Internet Access Businesses - License required.

It is unlawful for any person to engage in, conduct or carry on, in or upon any premises or real property located within the City, the activities of an Computer Gaming and Internet Access Business, unless such person has been granted a valid license pursuant to the provisions of this chapter. A separate license shall be required for each location within the City where a Computer Gaming and Internet Access Business is to be established. Public Use or Internet Learning Business shall be exempt from the license requirements herein.

§ 5-11.11 Term of license.

The term of a Computer Gaming and Internet Access Business license, unless sooner suspended or revoked, shall be one year.

§ 5-11.12 Renewal of license.

A Computer Gaming and Internet Access Business license, issued pursuant to the provisions of this chapter, that has not been suspended or revoked, may be renewed, upon payment of the renewal application fee, for a period not to exceed one year upon written application to the community development director made at least sixty (60) days prior to the expiration date of the current valid license. This application for renewal of a license shall contain all of the information required by Section § 5-11.120 of this chapter and shall be processed in accordance with the provisions of this chapter.

§ 5-11.20 License application and issuance.

A. Any person desiring to obtain a license or to renew an existing license to operate a Computer Gaming and Internet Access Business shall file a written application with the Community Development Director. The application shall be signed under the penalty of perjury. Prior to submitting the application, a nonrefundable fee, in an amount established by resolution of the City Council,

shall be paid to the City to defray the cost of the investigation and issuance required by this chapter. The license issuance or renewal fee required under this chapter shall be in addition to any other license or fee required under this code.

B. Neither the filing of an application for a license or renewal thereof nor payment of an application or renewal fee shall authorize the operation of a Computer Gaming and Internet Access Business until such license has been granted or renewed.

C. Each applicant for a Computer Gaming and Internet Access Business license or renewal thereof shall furnish the following information:

1. The present or proposed address where the business is to be conducted;
2. The full and true name under which the business will be conducted;
3. The full and true name and any other names used by the applicant and owner of the business, if the owner is not the applicant;
4. The applicant and owner's present residential and business addresses and telephone numbers;
5. Each residential and business address of the applicant and the owner for the five-year period immediately preceding the date of filing the application and the inclusive dates of each address;
6. The California driver's license or identification number of the applicant and owner;
7. A precise description of the activities and/or services to be provided;
8. A detailed site and floor plan of the proposed business, depicting the building and unit proposed and including interior dimensions and off-street parking spaces required by the city's zoning code;
9. A detailed description of the food and beverage service, if any, that will be offered to patrons;
10. The dates and hours during which the Computer Gaming and Internet Access Business is desired to be conducted and a list of the fees to be charged patrons;

11. The name(s) of the person(s) responsible for the operation, management, and supervision of the Computer Gaming and Internet Access Business;

12. A statement as to whether the applicant, owner, or any person to be responsible for the operation, management, and supervision of the Computer Gaming and Internet Access Business has, within the past five (5) years, had any permit or license issued in conjunction with a Computer Gaming and Internet Access Business in any jurisdiction, and whether during that period the license was suspended or revoked. If so, then the application shall provide the name of the issuing agency and an explanation of the suspension or revocation;

13. Signature of the property owner indicating approval of the submission of the license application; and

14. Such other information as the Community Development Director may require to discover the truth of the matters required to be set forth in the application.

D. The applicant shall present proof to the Community Development Director that the required application or application renewal fee has been paid, and shall present the application containing the information and supporting documentation required by subsection C of this section. A copy of the application shall be distributed to the City's Planning and Building Divisions, the Police Department and the Fire District for review.

E. When any change occurs regarding the written information required by subsection C of this section to be included in the application, the applicant or license holder, as the case may be, shall give written notification of such change to the Community Development Director within five (5) business days of such change.

F. The Community Development Director shall have a reasonable time, not to exceed thirty (30) days to investigate the facts set forth in the application and to receive comments from the City's Planning and Building Departments, the Police Department and the Fire District. The Community Development Director shall, within sixty (60) days after the date of the filing of the application, grant the license or renewal thereof only if it is found that all of the following requirements have been met:

1. The required fees have been paid;

2. The application and all information contained therein conform in all respects to the provisions of this chapter;

3. The applicant has not knowingly made a material misrepresentation of fact in the application;

4. The proposed Computer Gaming and Internet Access Business would comply with this chapter and all other applicable city, county and state laws including, but not limited to, health, zoning, fire and safety requirements and standards, and that, as proposed, the Computer Gaming and Internet Access Business would not tend to generate criminal activities, present unnecessary criminal opportunities, or tend to cause violations of curfews by minors due to failure to comply with Federal or State law or the Municipal Code including but not limited to Operational Standards set forth below ;

5. The applicant is at least eighteen (18) years of age;

6. The Computer Gaming and Internet Access Business site and floor plan have been reviewed by the City's Planning and Building Departments and the Police Department and Fire District, which have approved the same as well as all fire and panic safety equipment required to be installed; all requirements of the Americans with Disabilities Act have been satisfied; and that the maximum occupancy has been established, will be posted and will not likely be exceeded based on the floor plan; and,

7. The Community Development Director has not received evidence that the applicant has, within the previous five (5) years, had any license or entitlement to operate a Computer Gaming and Internet Access Business revoked due to the applicant's commission of a crime or violation of the operational standards or conditions of approval applicable to a Computer Gaming and Internet Access Business; provided, however, a Computer Gaming and Internet Access Business license may be granted subject to additional conditions designed to preclude a recurrence of the events or activities causing the prior license revocation.

G. If the Community Development Director does not find that all of the requirements of subsection F of this section have been met, the application shall be denied.

1. In the event that an application for a license or renewal thereof is denied, written notice of the denial shall be given to the applicant within sixty (60) days after the date of the filing of the application specifying the ground(s) of the denial and a description of the hearing rights provided by Section § 5-11.20(G)()2, below. Notice of denial of the application may be personally served or served by first-class postage prepaid and addressed to the applicant at the address set forth in the application. Mailed notice shall be deemed received three (3) days after mailing.

2. The decision of the Community Development Director may be appealed by filing a written notice requesting a hearing within ten (10) calendar days of the decision of the Community Development Director. The appeal may be heard by a Hearing Officer (for purposes of this section, the term Hearing Officer shall mean the City Manager or a Hearing Officer appointed by the City Manager) or by the Board of Administrative Appeals, pursuant to Chapter 4 of Title 1 of the Municipal Code.

a. The hearing shall be conducted within forty-five (45) days of the request.

b. The hearing shall be conducted under such rules of procedure as are appropriate to quasi-judicial proceedings, provided that the applicant and the City shall be entitled to present relevant evidence, testify under oath, and call witnesses who shall testify under oath. The Hearing Officer/Board of Administrative Appeals shall not be bound by the statutory rules of evidence in the hearing. The applicant shall have the burden of proof that the Community Development Director's determination was wrong. The hearing shall be recorded so that a transcript of the hearing can be prepared by either party.

c. At the conclusion of the hearing, the Hearing Officer/Board of Administrative Appeals shall decide whether the grounds for denial, revocation or non-renewal exist. Within ten (10) days after the conclusion of the hearing, the Hearing Officer/Board of Administrative Appeals shall file with the City Clerk, together with the recording of the hearing, a written decision supported by written findings based on the evidence submitted and a statement of the order. A copy of the decision shall be forwarded by certified mail, postage prepaid, to the applicant by the City Clerk. The decision of the Hearing Officer/Board of Administrative Appeals shall become effective three (3) days after its mailing to the applicant unless timely appealed as provided in the following Section.

H. The decision of the Hearing Officer or Board of Administrative Appeals shall be final unless appealed to the City Council by the filing of a written appeal with the City Clerk by the City Manager or member of the Council within ten (10) calendar days of mailing of the decision. All such appeals shall be filed with the City Clerk and shall be public records. The City Council shall, at a duly noticed meeting within forty-five (45) days from the date the written appeal was filed, independently review the entire record, including the recording or transcript of the hearing and any oral or written arguments which may be offered to the City Council by the appellant. At the conclusion of the review, a majority of the City Council members present may decide to sustain the decision, modify the decision, or order the decision stricken and issue such order as the City Council finds is supported by the entire record. The lack of a majority to take action means that the decision of the Hearing Officer or Board of Administrative Appeals remains in effect. The action of the City Council shall be final and

conclusive, shall be rendered in writing within ten days, and shall be immediately mailed or delivered to the applicant.

I. Notwithstanding any provisions in this chapter regarding the occurrence of any action within a specified period of time, the applicant may request additional time beyond that provided or may request a continuance regarding any decision or consideration by the City of the pending appeal. Extensions of time sought by applicants shall not be considered delay on the part of the City or constitute failure by the City to provide for prompt decisions on applications.

J. The time for a court challenge to a decision under this section is governed by California Code of Civil Procedure § 1094.8 and notice of the City's decision and its findings shall include citation to California Code of Civil Procedure § 1094.8.

§ 5-11.30 Transfer of license.

Unless prior application is made, thereafter approved, and a license issued thereon, upon the sale or transfer of any interest in a Computer Gaming and Internet Access Business, the license shall immediately become null and void. A new application must be made and a new fee paid by any person desiring to own or operate the Computer Gaming and Internet Access Business. Any application involving the sale or transfer of any interest in an existing Computer Gaming and Internet Access Business, as well as any license which may thereafter be granted, shall be subject to the provisions of this chapter.

§ 5-11.40 Alterations to Computer Gaming and Internet Access Businesses.

A. A holder of a valid Computer Gaming and Internet Access Business license shall notify the Community Development Director, in writing, of any proposed change in the business location, floor plan or business name at least thirty (30) days prior to such change.

B. Nothing in this section shall excuse the owner of a Computer Gaming and Internet Access Business from obtaining all other approvals necessary to change a location, floor plan or business name, including but not limited to building permits.

§ 5-11.50 License revocation.

A. If the City finds that any person holding an Computer Gaming and Internet Access Business license has violated or allowed the violation of any of the provisions of this chapter or has conducted business in a manner that could

have been grounds for license denial, the license may be revoked following notice and a hearing.

B. No revocation shall become effective until the license holder has been notified in writing of the right to a hearing pursuant to the provisions of section § 5-11.20(G) of this chapter. Notice of the pending revocation and right to appeal shall be given to the license holder either by personal delivery or registered mail, addressed to the license holder at the address set forth in the license application. Mailed notice shall be deemed received three (3) days after mailing.

C. If a request for hearing is filed within ten (10) calendar days from the notice provided in B above, the City shall conduct an appeal hearing as provided in section § 5-11.20(G) H, I and J, above. The revocation shall be stayed pending the decision, unless, in the determination of the City Manager, immediate suspension pending the hearing is necessary due to an immediate threat to the public health, safety or welfare. Otherwise, the revocation shall become effective upon expiration of the appeal period.

§ 5-11.60 Operational standards and regulations.

A. Prohibitions regarding Minors.

1. Minors (under 18 years of age), unless legally emancipated, shall not be permitted to enter or remain in a Computer Gaming and Internet Access Business during any time that he or she is required to be in attendance at school unless accompanied by a parent or legal guardian.

2. Minors (under 18 years of age), unless legally emancipated, shall not be permitted to enter or remain in a Computer Gaming and Internet Access Business during the hours of the Juvenile Protection Curfew of 11:01 p.m. through 5:00 a.m. seven nights a week, pursuant to Article 2 of Chapter 10 of Title 5 of the Antioch Municipal Code.

3. Signs shall be placed at the entrance of the business and inside the business setting forth these restrictions in lettering of at least two (2) inches in size.

B. Hours of Operation. The Computer Gaming and Internet Access Business shall not be open to customers, patrons or any member of the public between the hours of 12:00 a.m. and 8:00 a.m. on Friday, Saturday and Sunday or between the hours of 11:00 p.m. and 8:00 a.m. Monday through Thursday.

C. Interior Waiting Area. An interior waiting area with not less than eight (8) seats shall be provided for customers waiting to use a computer. The number of seats shall be increased by one (1) for every five (5) additional

computers beyond twenty-five (25) computers in the business. No outside waiting or seating area is permitted.

D. No Smoking or Consumption of Alcoholic Beverages. No person shall be permitted to smoke or consume alcoholic beverages on the inside of the premises. The sale of cigarettes and alcohol on the premises is prohibited. No intoxicated or disorderly person shall be allowed to remain on the premises.

E. Staffing. Employees shall be at least 18 years of age. There shall be a minimum of two (2) employees staffing the Computer Gaming and Internet Access Business during all working hours with at least one manager or supervisor. The ratio of employees to computers and/or other electronic devices that access the internet shall be 2:15. During each employee's working hours, the employee shall wear a badge identifying the business and the employee's full name. Security personnel indicated in Section below shall not be included in this minimum staffing number

F. Occupancy. Occupancy shall not exceed that required under the Uniform Building Code and Uniform Fire Code. The maximum occupancy load shall be posted at the main entrance.

G. Surveillance System.

1. The Chief of Police may require a Computer Gaming and Internet Access Business operator to install a digital camera/video surveillance system on the premises in the event there are or have been repeated calls for police services relating to the premises including, but not limited to, assaults, public intoxication, vandalism, gang activity, weapons offenses, disturbances of the peace and juvenile crimes including truancy.

2. In the event of such a determination, the establishment shall maintain and operate a camera/video surveillance system during all business hours. The system shall cover the entire interior of the premises and all entrances to and exits from the establishment. Tapes/disks shall be kept a minimum of fourteen (14) calendar days, or as required by the Chief of Police. The owner shall permit a representative of the Police Department's office to inspect the tapes/disks during business hours.

3. A sign shall be posted inside and at the entrances to the establishment indicating that the premises are under camera/video surveillance.

H. Window Coverings. Window areas shall not be covered, tinted or made opaque in any way, or obscured in any way by landscaping, floor displays, equipment or the like, excepting during daylight hours when partial blinds or other equivalent window coverings may be used as long as the interior remains visible from the public right of way.

I. Security Guards.

1. The Chief of Police may require a specific Computer Gaming and Internet Access Business operator to provide a security guard(s) on the premises in the event there are repeated calls for police services relating to the premises including, but not limited to, assaults, gang activity, weapons offenses, disturbances of the peace and juvenile crimes including truancy.

2. The security guard shall be uniformed and be employed by a Private Patrol Operator that is currently licensed with the California Department of Consumer Affairs. The name of the Patrol Operator with state license number and the guard registration numbers shall be provided to the Community Development Department. Any changes to the Patrol Operator shall be approved by the Police Chief at least two working days prior to Patrol Operator taking over security at the business.

3. The security guard shall also patrol the exterior of the business and any parking lot areas.

4. The Chief of Police may require more than one security guard if there are more than fifteen (15) computers or similar devices or continued repeated calls for service indicate that one security guard is not adequate.

J. No Adult Entertainment Business or Adult Boutique. Any access to adult entertainment oriented web sites, as defined in section 9-5.203 of this code, is prohibited unless specifically permitted under sections 9-5.3808 or 9-5.3808.1 of this code.

K. No Other Amusement Devices. No pool tables or other amusement devices not directly related to the internet and similar computer devices shall be permitted in the business.

L. No Tournaments. No gaming tournaments for cash prizes deemed to be gambling under the provisions of State Law shall be permitted.

M. Interior Signs. User rates and other fees must be conspicuously posted on the premises.

N. No Illegal Gambling. Under no circumstances shall electronic game machines, which include computers and other amusement devices, be used for illegal gaming or gambling. The applicant shall be responsible for ensuring customers do not use any electronic game machine for illegal gaming or gambling.

O. No Litter. The applicant shall provide adequate trash receptacles both inside and outside of the building. The applicant shall keep the outside of the business, including the parking lot, free of litter, trash and debris.

P. No Private Booths. Any booth or individual computer use area within the business shall be visible from a continuous and accessible main aisle in a public portion of the Computer Gaming and Internet Access Business, and shall not be obscured by any door, curtain, wall, two-way mirror or other device which would prohibit a person from seeing the entire interior of the booth/individual viewing area from the main aisle. Further, no one shall maintain any booth/individual viewing area in any configuration unless the entire interior wherein the computer that is being used is visible from one main aisle. No doors are permitted on a booth/individual viewing area. No partially or fully enclosed booth/individual viewing areas or partially or fully concealed booth/individual viewing areas shall be maintained.

Q. Alarm System. The Chief of Police may require a specific Computer Gaming and Internet Access Business operator to install an alarm system that distinguishes between a burglary and a robbery. The system shall monitor twenty-four hours per day. All public entrance and exit doors to the business shall have electronic monitoring system that produce a sound when a person transverses the doorway. If required by the Chief of Police, the system shall be electronically connected with the police department if activated.

R. Number of Computers. The number of computers or similar devices in a Computer Gaming and Internet Access Business shall not exceed thirty square feet of floor area per computer of the floor area that is dedicated to the placement of computers for rent or charge.

§ 5-11.70 Abatement of nuisance.

Any Computer Gaming and Internet Access Business operated, conducted or maintained contrary to the provisions of this chapter shall be and hereby is declared to be unlawful and a public nuisance, and the City may, in addition to or in lieu of any other remedy, commence an action or proceeding for the abatement, removal or enjoyment thereof, and may take such other steps and may apply to such court or courts as may have jurisdiction to grant such relief to abate or remove such establishment and restrain and enjoin any person from operating, conducting or maintaining a Computer Gaming and Internet Access Business contrary to the provisions of this chapter.

§ 5-11.90 Penalty.

It shall be unlawful for any person to violate any provision or to fail to comply with any of the requirements of this chapter. Any person violating, permitting or causing the violation of this chapter shall be deemed guilty of a

misdemeanor and upon conviction thereof shall be punished as set forth in chapter 1-2.01 of this code, or any successor provision thereto. Each person shall be deemed guilty of a separate offense for each and every day, or any portion thereof, during which any violation of any provision of this chapter is committed, continued or permitted by such person and shall be deemed punishable therefore as provided in this section.

§ 5-11.90 License fees.

The City Council shall, by resolution, set a fee for application for a Computer Gaming and Internet Access Business license. Until such fee is set, the application fee shall be the minimum fee currently established for the application extension fee in the City's Master Fee Schedule."

SECTION 3. Compliance for Existing Business; Time. It is the desire and intent of the City Council that any and all existing and legal Computer Gaming and Internet Access Businesses come into compliance with the terms of this Ordinance as rapidly as possible and that all applications, review and decisions be processed on an expedited basis. Within fourteen (14) calendar days of the effective date of this ordinance, every existing Computer Gaming and Internet Access Business shall file a statement with the Community Development Director evidencing its compliance with all provisions of this chapter and providing all information as provided in § 5-11.40. The review and determination of the Community Development Director shall be provided within fourteen (14) days of the filing of the application. In the event that the license requires the installation of improvements at the business (e.g., lighting, surveillance, etc) all such improvements shall be installed per a schedule agreed by the Community Development Director; however, not to exceed twenty-one (21) days following the determination of the Community Development Director on the license application.

SECTION 4. CEQA. This ordinance is not a project within the meaning of Section 15378 of the State CEQA (California Environmental Quality Act) Guidelines, because it has no potential for resulting in physical change in the environment, directly or ultimately. In the event that this Ordinance is found to be a project under CEQA, it is subject to the CEQA exemption contained in CEQA Guideline section 16061 (b) (3) because it can be seen with certainty to have no possibility of a significant effect on the environment.

SECTION 5. Severability. If any section, subsection, subdivision, sentence, clause, phrase, or portion of this Ordinance is, for any reason, held to be invalid or unconstitutional by the decision of any court of competent jurisdiction, such decision shall not affect the validity of the remaining portions of this Ordinance. The City Council hereby declares that it would have adopted this Ordinance, and each section, subsection, subdivision, sentence, clause, phrase, or portion thereof, irrespective of the fact that any one or more sections, subsections, subdivisions, sentences, clauses, phrases, or portions thereof be declared invalid or unconstitutional.

SECTION 6. Effective Date. This Ordinance shall take effect thirty (30) days after adoption as provided by Government Code Section.

SECTION 7. Publication; Certification. The City Clerk shall certify to the adoption of this Ordinance and cause same to be published in accordance with State law.

* * * * *

I **HEREBY CERTIFY** that the foregoing Ordinance was introduced on 28th day of February, 2012 and adopted at a regular meeting of the City Council of the City of Antioch on _____, 2012, by the following vote:

AYES:

NOES:

ABSENT:

ABSTAIN:

James D. Davis, Mayor of the City of Antioch

ATTEST:

Denise Skaggs, City Clerk of the City of Antioch

ATTACHMENT "D"

RESOLUTION NO. 2012/**

RESOLUTION OF THE CITY COUNCIL OF THE CITY OF ANTIOCH ADOPTING A RESOLUTION OF INTENT TO INITIATE AN AMENDMENT TO CHAPTER 5 OF TITLE 9 OF THE ANTIOCH MUNICIPAL CODE TO ADDRESS COMPUTER GAMING AND INTERNET ACCESS BUSINESSES

WHEREAS, Computer Gaming and Internet Access Business" shall mean an establishment that provides more than four (4) computers or other electronic devices for access to the world wide web, internet, e-mail, video games or computer software programs which operate alone or are networked (via LAN, WAN or otherwise) or which function as a client/server program, and which seeks compensation, in any form, from users; "Computer Gaming and Internet Access Business" is synonymous with a personal computer ("PC") café, internet café, cyber café, sweepstakes gaming facilities, business center, internet sales business and internet center, but does not include a Public Use or Internet Learning Center, which is defined as an establishment that provides computer access which is operated by the City of Antioch, a school district, a library, a college district, or a private institution of learning which provides classes in computer instruction or a non-profit organization which does not receive compensation in any form other than school tuition; and

WHEREAS, the City has received and anticipates additional requests for the construction, establishment and operation of Computer Gaming and Internet Access Businesses within the City; and

WHEREAS, the City of Antioch, as well as neighboring cities, have experienced criminal activity associated with Computer Gaming and Internet Access Businesses, including incidents involving robbery, illegal drug use and sales, burglary, assaults, public intoxication, vandalism and property damage and loitering; and

WHEREAS, there have been complaints about prostitution associated with these uses and it is known that other cities have experienced significant gang-related activities occurring at these Computer Gaming and Internet Access Businesses; and

WHEREAS, the City Council has determined that the provisions of the City Municipal Code that may regulate the construction, operation and establishment of Computer Gaming and Internet Access Businesses in the City are inadequate and need review, study, and revision to fully take into account the impacts related to the location and manner of construction, establishment and operation of Computer Gaming and Internet Access Businesses, and the related public health, safety, and welfare concerns, including but not limited to the impacts they may have on parking, surrounding uses, and the community;

NOW THEREFORE BE IT RESOLVED that the City Council of the City of Antioch adopts this resolution of intention to initiate an amendment to Chapter 5 of Title 9 of the Antioch Municipal Code to address land use issues with Computer Gaming and Internet Access Businesses

RESOLUTION NO. 2012/**
February 28, 2012
Page 2

* * * * *

I HEREBY CERTIFY that the foregoing resolution was duly passed and adopted by the City Council of the City of Antioch, California, at a regular meeting thereof held on the 28th day of February 2012, by the following vote:

AYES:

NOES:

ABSENT:

DENISE SKAGGS, City Clerk

D2

ATTACHMENT "E"

CITY OF ANTIOCH BUSINESS LICENSE APPLICATION



DUE BY:
BUSINESS NO: 3005779
CLASS CODE:

INSTRUCTIONS

Hold License Cert. for Pick up
give to [redacted]

1. MAILING NAME & ADDRESS IPG Inc. [redacted] Spring Hill, FL 34606		2. BUSINESS NAME IPG Inc. dba Rapid Business Solutions	
5. PHONE 914-498-3629		6a. CELL PHONE 914-[redacted]	
6b. FAX 815-349-2829		6c. E-MAIL ADDRESS internetpromotiongroup@gmail.com	
3. BUSINESS ADDRESS 1892 A Street			
4. BUSINESS CITY, ST, ZIP Antioch, CA 94509			
7. BUSINESS DESCRIPTION Offer consumers print, copy, fax services, and internet access			
8. FED ID# [redacted]	9. STATE ID# [redacted]	10. SELLER'S PERMIT# [redacted]	11. HOME OCCUPATION# [redacted]
12. OWNER TYPE (Sole Proprietorship, Partnership, CORP, Trust) [redacted]		13. CERTIFICATION NO. [redacted]	14. NUMBER OF EMPLOYEES [redacted]
15. OWNER#1 NAME James Hayes		16. OWNER#2 NAME Gino Ciaschetti	
17. OWNER#1 ADDRESS (NO PO BOXES, STATE REQUIREMENT) [redacted]		18. OWNER#2 ADDRESS (NO PO BOXES, STATE REQUIREMENT) [redacted]	
19. OWNER#1 CITY, ST, ZIP Dunedin, FLORIDA 34697		20. OWNER#2 CITY, ST, ZIP Humble, TX 77396	
21. OWNER#1 HOME PHONE 914-[redacted]		22. OWNER#2 HOME PHONE 713-[redacted]	
23. OWNER#1 SSN [redacted]	24. OWNER#1 DL [redacted]	25. OWNER#2 SSN [redacted]	26. OWNER#2 DL [redacted]
27. CONTACT NAME Jimmy Hayes or Gino Ciaschetti		28. CONTACT PHONE 914-[redacted] or 713-[redacted]	
29. LICENSE TYPE (Office use only)	29A. INTERNET ADDRESS internetpromotiongroup@gmail.com		
30A. GROSS RECEIPTS	30B. NUMBER OF CARD TABLES	30C. NUMBER OF VEHICLES	
31. LICENSE FEE [redacted]	32.	33. APPLICATION FEE [redacted]	
34. TOTAL AMOUNT DUE (combine lines 31, 32 & 33) [redacted]		35. DATE BUSINESS TERMINATED (IF OUT OF BUSINESS)	
OFFICE USE ONLY			
Effective Date: Purchase Date: EEB 16 2011	Expir. Date: Receipt No: 406542	Planning Dept: <i>[initials]</i>	Bldg Dept: <i>[initials]</i>
		Zoning: C-2	Health Dept:

The undersigned, being authorized to make this Application, hereby declares to the best of his knowledge and belief that this is a true, correct, and complete Application made pursuant to the Antioch Municipal Code.

Sign Here

[Signature]
Signature

2-14-2011
Date

**CITY OF ANTIOCH
BUSINESS LICENSE RENEWAL**



DUE BY
BUSINESS NO. 3004793
CLASS CODE

INSTRUCTIONS			
1. MAILING NAME & ADDRESS 15 internet cafe [REDACTED] Antioch CA 94531		2. BUSINESS NAME 15 internet cafe	
3. BUSINESS ADDRESS 1653 A St		4. BUSINESS CITY, ST, ZIP Antioch CA 94509	
5. PHONE 925 522 0801	6a. EMERGENCY PHONE 925 [REDACTED]	6b. FAX	6c. E-MAIL ADDRESS Aevent@emember.comcast.net
7. BUSINESS DESCRIPTION internet cafe			
8. FED ID#	9. STATE ID#	10. SELLER'S PERMIT#	11. HOME OCCUPATION#
[REDACTED]	[REDACTED]	[REDACTED]	[REDACTED]
12. OWNER TYPE (Sole Proprietorship, Partnership, CORP, Trust)		13. CERTIFICATION NO.	14. NUMBER OF EMPLOYEES
[REDACTED]		[REDACTED]	[REDACTED]
15. OWNER#1 NAME Patricia Simpson		16. OWNER#2 NAME	
17. OWNER#1 ADDRESS (NO PO BOXES / STATE REQUIREMENT)		18. OWNER#2 ADDRESS (NO PO BOXES / STATE REQUIREMENT)	
[REDACTED]		[REDACTED]	
19. OWNER#1 CITY, ST, ZIP Antioch CA 94531		20. OWNER#2 CITY, ST, ZIP	
21. OWNER#1 HOME PHONE 925 [REDACTED]		22. OWNER#2 HOME PHONE	
23. OWNER#1 SSN		25. OWNER#2 SSN	26. OWNER#2 DI
[REDACTED]		[REDACTED]	[REDACTED]
27. CONTACT NAME Patricia Simpson		28. CONTACT PHONE 925 [REDACTED]	
29. LICENSE TYPE (Office use only)		29a. INTERNET ADDRESS	
[REDACTED]		[REDACTED]	
30a. GROSS RECEIPTS	30b. NUMBER OF CARD TABLES	30c. NUMBER OF VEHICLES	
[REDACTED]	[REDACTED]	[REDACTED]	
31. LICENSE FEE	32. PENALTY	33. APPLICATION FEE	
[REDACTED]	[REDACTED]	[REDACTED]	
34. TOTAL AMOUNT DUE (combine lines 31, 32 & 33)		35. DATE BUSINESS TERMINATED (IF OUT OF BUSINESS)	
[REDACTED]		[REDACTED]	
OFFICE USE ONLY			
Effective Date	Expir. Date: 4-30-11	Planning Dept. [Signature]	Bldg. Dept. [Signature]
Purchase Date	Receipt No. 412134	Zoning [Signature]	Health Dept.
The undersigned, being authorized to make this Application, hereby declares to the best of his knowledge and belief that this is a true, correct, and complete Application made pursuant to the Antioch Municipal Code.			
Sign Here [Signature]		Date: 4-16-11	
Signature		Date	

**CITY OF ANTIOCH
BUSINESS LICENSE
DELINQUENCY NOTICE**

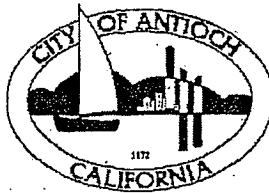

DUE BY: 05/30/2010
BUSINESS NO 3004773
CLASS CODE: 0 - 0

INSTRUCTIONS			3rd Notice
Please review the complete form and make corrections to this side. Complete lines 30, 31, 32, 33 and 34. Use schedule on reverse side to calculate fees.			
Your license fee is delinquent, add a 10% penalty if paid after due date			
1. MAILING NAME & ADDRESS T'S INTERNET CAFE [REDACTED] ANTIOCH, CA 94531-6357 [Barcode]		2. BUSINESS NAME T'S INTERNET CAFE	
		3. BUSINESS ADDRESS 1836 A ST	
		4. BUSINESS CITY, ST, ZIP ANTIOCH, CA 94509-2602	
5. PHONE (925)522-0801	6a. EMERGENCY PHONE 925-[REDACTED]	6b. FAX	6c. E-MAIL ADDRESS:
7. BUSINESS DESCRIPTION INTERNET SALES			
8. FED ID#	9. STATE ID#	10. SELLERS'S PERMIT #	11. HOME OCCUPATION #
12. OWNER TYPE (Sole Proprietorship, Partnership, CORP, Trust) [REDACTED]		13. CERTIFICATION NO.	14. NUMBER OF EMPLOYEES
15. OWNER #1 NAME Patricia Cooper Simmons		16. OWNER #2 NAME	
17. OWNER #1 ADDRESS (NO PO BOXES, STATE REQUIREMENT) [REDACTED]		18. OWNER #2 ADDRESS (NO POBOXES, STATE REQUIREMENT)	
19. OWNER #1 CITY, ST, ZIP Antioch CA 94531		20. OWNER #2 CITY, ST, ZIP	
21. OWNER #1 HOME PHONE Kevin Amadio		22. OWNER #2 HOME PHONE	
23. OWNER #1 SSN [REDACTED]	24. OWNER #1 DL [REDACTED]	25. OWNER #2 SSN	26. OWNER #2 DL
27. CONTACT NAME Patricia Cooper Simmons		28. CONTACT PHONE	
29. LICENSE TYPE (Office use only)	29A INTERNET ADDRESS		
30A. GROSS RECEIPTS	30B. NUMBER OF CARD TABLES 2	30C. NUMBER OF VEHICLES [REDACTED]	
31. LICENSE FEE [REDACTED]	32. PENALTY [REDACTED]	33. APPLICATION FEE [REDACTED]	
34. TOTAL AMOUNT DUE (combine lines 33, 34 & 35) [REDACTED]		35. DATE BUSINESS TERMINATED (IF OUT OF BUSINESS)	
OFFICIAL USE ONLY			
Effective Date: 05/01/2010	Expir. Date: 04/30/2011	Planning Dept:	Bldg Dept:
Purchase Date: JUN 23 2010	Receipt No: 348181	Zoning:	Health Dept:
The undersigned, being authorized to make this Application, hereby declares to the best of his knowledge and belief that this is a true, correct, and complete Application made pursuant to the Antioch Municipal Code.			
Sign Here [Signature]		Date 6-21-10	

**CITY OF ANTIOCH
BUSINESS LICENSE APPLICATION**



DUE BY
BUSINESS NO. 3006114
CLASS CODE

INSTRUCTIONS

1. MAILING NAME & ADDRESS <u>COT on the web</u> <u>2333A Buchanan</u> <u>Antioch CA 94509</u>		2. BUSINESS NAME <u>Cot on the web</u>	
3. BUSINESS ADDRESS <u>2333A Buchanan</u>		4. BUSINESS CITY, ST, ZIP <u>Antioch CA 94509</u>	
5. PHONE <u>925 209 8332</u>	6. ALT. PHONE <u>[REDACTED]</u>	8. CELL PHONE <u>925 [REDACTED]</u>	9. FAX NUMBER
6. EMAIL ADDRESS <u>Aevent@remembers.com</u>		7. BUSINESS DESCRIPTION <u>Fax Copy Print internet</u>	
8. FED ID#	9. STATE ID#	10. SELLER'S PERMIT#	11. HOME OCCUPATION#
12. OWNER TYPE (Sole Proprietorship, Partnership, CORP, Trust)		13. CERTIFICATION NO.	14. NUMBER OF EMPLOYEES
15. OWNER #1 NAME <u>Patricia Simmons LLC</u>		16. OWNER #2 NAME	
17. OWNER #1 ADDRESS (NO PO BOXES, STATE REQUIREMENT)		18. OWNER #2 ADDRESS (NO PO BOXES, STATE REQUIREMENT)	
19. OWNER #1 CITY, ST, ZIP <u>Antioch CA 94531</u>		20. OWNER #2 CITY, ST, ZIP	
21. OWNER #1 HOME PHONE <u>925 [REDACTED]</u>		22. OWNER #2 HOME PHONE	
23. OWNER #1 SSN	24. OWNER #1 DL	25. OWNER #2 SSN	26. OWNER #2 DL
27. CONTACT NAME <u>Patricia Simmons</u>		28. CONTACT PHONE	
29. LICENSE TYPE (Office Use only)	29A. INTERNET ADDRESS		
30A. GROSS RECEIPTS	30B. NUMBER OF CARD TABLES	30C. NUMBER OF VEHICLES	30D. STICKER FEE (\$5/VEHICLE)
31. LICENSE FEE <u>[REDACTED]</u>	32. PENALTY	33. APPLICATION FEE <u>[REDACTED]</u>	
34. TOTAL AMOUNT DUE (combine lines 31, 32 & 33) <u>[REDACTED]</u>		35. DATE BUSINESS TERMINATED (IF OUT OF BUSINESS)	
OFFICE USE ONLY			
Effective Date	Expir. Date	Planning Dept. <u>B</u>	Bldg Dept. <u>MB</u>
Purchase Date <u>SEP 29 2011</u>	Receipt No. <u>450689</u>	Zoning <u>B3</u>	Health Dept.

The undersigned, being authorized to make this Application, hereby declares to the best of his knowledge and belief that this is a true, correct, and complete Application made pursuant to the Antioch Municipal Code.

Sign Here Patricia Simmons
Signature _____ Date _____

ATTACHMENT "F"

ADDRESS	BUSINESS	Before Internet Café		Internet Café		%Change
		2/16/10 - 2/15/11	Totals	2/16/11 - 2/15/12	Totals	
Delta Fair BL		109		259		137.61%
2954	CA Check Cashing	52		124		138.46%
2958	Super Wine	44		77		75.00%
2962	Internet Room	0		15		nc
2970	Gold Palace	0		3		
2974	UPS Store	7		15		114.29%
2980	The OTS group	0		7		
2982	Geeta's Herbal Spa & Salon	3		6		100.00%
2996		1		0		
3000	Better Homes Realty	2		11		450.00%

Sample types of Calls	Before Internet Café		Internet Café		%Change
	2/16/10 - 2/15/11	Totals	2/16/11 - 2/15/12	Totals	
CA Check Cashing					
DISPO CLASS					
MSDS	7		21		200.00%
SUSC	7		16		128.57%
ATMC	7		19		171.43%
DRUN	0		3		
FINF	0		11		
LOIT	0		5		
Super Wine					
DISPO CLASS					
ATMC	9		14		55.56%
AUTT	0		2		
MSDS	7		21		200.00%
SUSC	3		12		300.00%

ADDRESS	BUSINESS	Before Internet Café		Internet Café		After Internet Café		
		2/1/09-8/30/09	2009	2/1/10-8/30/10	2010	2/1/11-8/30/11	2011	%Change
	Totals	157	157	240	240	158	158	-34.17%
1800	Gas of America	29	29	59	59	40	40	-32.20%
1806	Juarez	7	7	8	8	9	9	12.50%
1808		1	1	0	0	1	1	nc
1818	Grocery Outlet	49	49	50	50	31	31	-38.00%
1826		0	0	1	1	0	0	-100.00%
1828		4	4	0	0	4	4	nc
1836	Internet Café	0	0	27	27	0	0	-100.00%
1840	Gold Star	1	1	9	9	2	2	-77.78%
1844		0	0	0	0	2	2	nc
1848	Quick Check	2	2	5	5	1	1	-80.00%
1852		3	3	1	1	1	1	0.00%
1860	Lamothe Cleaners	3	3	9	9	7	7	-22.22%
1864		1	1	1	1	0	0	-100.00%
1868	Delta Vaccum	1	1	5	5	3	3	-40.00%
1870	CCC Fed Credit Union	4	4	1	1	1	1	0.00%
1872	Berrys	1	1	0	0			
1884	Thai Cuisine	0	0	2	2	1	1	-50.00%
1888	Cheers	0	0	4	4	4	4	0.00%
1890	Rock Bottom Records	6	6	9	9	5	5	-44.44%
1892	Minute Man Press	1	1	0	0	1	1	nc
1894	STARBUCKS	29	29	1	1	2	2	100.00%
1896	STARBUCKS	15	15	48	48	43	43	-10.42%

ADDRESS	BUSINESS	Before Internet Café		Internet Café		5.5 months	
		9/1/09-8/31/10	9/1/10-8/31/11	%Change	After Internet Café	09/01/11 - 2/15/12	
A ST	Totals	166	279	68.07%	72	27	
1611	Cruisers	61	72	18.03%	6	22	
1615	Fireside Thrift	10	57	23.91%	0	3	
1623	Auto Zone	46	6	-33.33%	0	0	
1625	The Beauty Source	9	15	650.00%	0	0	
1631	Delta Barber	2	1	nc	0	0	
1633		0	3	nc	0	0	
1635	Russell's Cheesecake	0	5	400.00%	2	2	
1639		1	4	-80.95%	0	0	
1641	World Fashion	21	4	100.00%	4	4	
1645	Los Caporalles	2	4	nc	5	5	
1653	Internet Café	0	12	100.00%	0	0	
1657	Launderland	6	2	nc	0	0	
1661		0	24	200.00%	1	1	
1663	Dollar Store	8					

ADDRESS	BUSINESS	Before Internet Café		Internet Café	
		8/20/10-12/31/10	8/20/11-12/31/11	%Change	
A ST	Totals	3	38	1166.67%	
1900		1	4	300.00%	
1908	Internet Café	0	4	nc	
1912	APEX	2	0	-100.00%	

ADDRESS	BUSINESS	Before Internet Café		Internet Café		%Change
		9/1/10 - 2/15/11	9/1/11 - 2/15/12	9/1/11 - 2/15/12	9/1/11 - 2/15/12	
BUCHANAN RD	Totals	7	19	19	171.43%	
2327	OKAWA	2	2	2	0.00%	
2329	Brooks & Books	0	1	1		
2331 #A	Serenity Salon & Spa	0	2	2		
2331 #B	Black Diamond Print	0	3	3		
2333 #A	COT on the Web	0	5	5		
2333 #B	Dominos Pizza	5	5	5	0.00%	

ATTACHMENT "G"

CALLS FOR SERVICE
2962 DELTA FAIR BL
2/16/11 - 2/15/12

PRINTED:2/16/2012

EVENT#	RCV TIME	CLASS	DISPO	CASE#	SYNOPSIS
11068917	7/26/11 0:46	MSIN	MSIN		NEW INTERNET CAFE - NAME AND LOCATION NOTED FOR ADDITION TO CAD.
11097719	10/16/11 20:29	911U	911U		NVC/VOIP LINE
11109110	11/21/11 12:46	MEDPD	FIDA		FIRE ENRT FOR A MALE LAYING ON THE GROUND, BARELY CONSCIOUS
11109512	11/22/11 18:18	27SUB	WRNO	11010014	OV NEW CASE FOR WARRANT/ [REDACTED]
11116985	12/17/11 0:40	FINF	FINF		MALE FELL OUTSIDE IS BLEEDING FROM SIDE OF HIS FACE
12001418	1/5/12 15:37		CANC		
12002550	1/9/12 2:00	96	WRNO	12000286	
12007174	1/24/12 2:06		VCOO		
12007425	1/24/12 22:00	415V	DISC		VERB WITH SUBJ IFO LOC
12008291	1/27/12 19:49	415UG	MSDS		GROUP IFO REFUSING TO LEAVE.. RP IS OTS SECURITY
12008631	1/28/12 22:11	10851	CIVI		2007 GRY DODGE MAGNUM [REDACTED] (LOC VIA DMV) RP SAID HE JUST MET SOME GUY AND HE ALLOWED HIM TO DRIVE HIS VEH TO THIS LOC SO RP COULD USE THE RESTROOM BEF THEY WENT OVER THE HILL TO "DO SOME BUSN" WHEN RP CAME OUT, UNK MALE THAT HE JUST MET WAS GONE WITH RPS VEH.....
12008717	1/29/12 8:39	10851	CIVI		OCC SOMETIME DURING THE NIGHT 07 GRY DODGE MAGNUM LIC [REDACTED]
12009234	1/30/12 22:56	1059	XPAT		
12009256	1/31/12 1:30	96	VCOO	12001054	
12011363	2/6/12 22:29	VCOO	VCOO		
12011680	2/8/12 0:51		ATMC		

TOTAL # EVENTS 16

TOTAL # CASES 3

{EVENT_MAIN.ADDR_ST} = "DELTA FAIR BL" and
{EVENT_MAIN.ADDR_NUM} = "2962" and
{EVENT_MAIN.RCV_TIME} in DateTime (2011, 02, 16, 00, 00, 00) to DateTime (2012, 02, 15, 23, 59, 59)

h:\Crystal Reports\CFS Reports\InternetCafes\CFS-Syn-2962DFB.rpt

Report is based on unaudited CAD/RMS data at time of report generation.
Report for analysis purposes only - not for distribution - Law Enforcement Use Only

CALLS FOR SERVICE
1908 A ST
8/20/11 - 12/31/11

PRINTED:2/16/2012

<u>EVENT#</u>	<u>RCV TIME</u>	<u>CLASS</u>	<u>DISPO</u>	<u>CASE#</u>	<u>SYNOPSIS</u>
11077745	8/20/11 22:26	415UG	MSDS		HMA LSW RED HAT RED SHIRT IFO THROWING THINGS AT THE BUSN AND YELLING THAT HE IS GOING TO COME BACK AND HURT THE EMP'S... PER RP THE BUSN JUST MOVED AND THEY ARE NOW AT 1908 A ST .. [REDACTED] CAME IN AS 1653 A ST .. WAS ADV TO CONTACT PHONE COMPANY TO CORRECT .. PLS HAVE OFCR CONFIRM ADDRESS WHEN 97
11078136	8/22/11 7:58		ACCN	11006858	
11086692	9/15/11 0:54	417	SUSC		OCCRD AT 19TH/ D ST
11089401	9/22/11 22:25	PTOW	PTOW		5 AGO ... MALE POINTED THE GUN AT RP AND COCKED IT 91 CHEV VAN WHI CALIC #4 [REDACTED] LEFT ON PREMISE W/O PERMISSION
11090260	9/25/11 2:03	647F	DRUN	11007953	IN SMOKING AREA IN THE BACK OF THE BLDG.. 1051 WF BLN HAIR LSW BLK SHIRT AND BLU JEANS REFUSING TO LEAVE.... ACTING VERY AGGRESSIVE
11091081	9/27/11 18:19	95	NARC	11008041	
11094268	10/6/11 22:42	96	AUTR	11008369	
11094358	10/7/11 6:42	SUSP	SUPP		RP SAID POLICE WERE LOOKING FOR A MALE RE A 10851 VEH...RP SAID THE MALE IS BACK, WM YELLOW HAT, THIN BUILD...MALE RAN OFF WB ON W 20TH....NFI
11096757	10/14/11 1:32	94	WRNO	11008608	TRO ON W 20TH
11096763	10/14/11 1:54	96	MSNF	11008609	SEP INC FOR THE 96
11097174	10/15/11 5:09	SUSP	SUPP		[REDACTED] IS IFO T'S INTERNET IN MULTIPLE COLOR ZIP UP HOODIE, BLK PANTS, WHI SHOES. SUBJ SHOULD HAVE PC ON A 288 CASE
11098790	10/20/11 1:41	FINF	FINF		F/A ENRT FOR CUSTOMER FEELING ILL, SWELLING IN LEGS AND HANDS, SUFFERS FROM LUPIS, CONSCIOUS AND BREATHING
11098824	10/20/11 4:58	FINF	FINF		MALE 24YS POSS ASTHMA ATTACK, AWAKE
11098851	10/20/11 8:11		WRNO	11008857	
11100420	10/24/11 21:56		WRNO	11009027	
11100726	10/25/11 23:27	94	FIED		
11101053	10/27/11 2:40	SUSV	SUSC		RP RECVD INFO THAT HIS GIRLF [REDACTED] 37 YO LEFT IN A 10851 WHI HOND ACC WITH 3 BM'S AND ARE PARKED AT THE ABOVE BUSN - NFI
11101413	10/28/11 3:18	415V	DISC		TO THE REAR OF BUSN, 6 MALES ARGUING. RP CLAIMS SOMEONE HAS A GUN BUT WHEN QUESTIONED FURTHER MALE SAID HE DOESN'T KNOW AND HUNG UP
11101754	10/28/11 23:06	FINF	FINF		ANOTHER CALL OF ODOR OF NATURAL GAS..CONFIRE 49
11103379	11/2/11 19:06	415UG	SUSC		BELLIGERNT FEMALE ON 19TH SIDE OF STORE.. ASKED TO LEAVE SO SHES UPSET
11105196	11/8/11 20:34	94	SUSC		WFA WRG BABY BLUE TANK TOP
11105283	11/9/11 8:36	94	WRNO	11009540	BEH THE ABOVE
11106500	11/13/11 2:01	96	VCOO		X21, [REDACTED] HAT DK PLAID SWTER

Report is based on unaudited CAD/RMS data at time of report generation.
 Report for analysis purposes only - not for distribution - Law Enforcement Use Only

<u>EVENT#</u>	<u>RCV TIME</u>	<u>CLASS</u>	<u>DISPO</u>	<u>CASE#</u>	<u>SYNOPSIS</u>
11109312	11/22/11 5:01	415UG	SRVC		BMA 20'S REFUSING TO LEAVE AFTER FALLING ASLEEP AT THE STATION AND RUNNING OUT OF MONEY/ TIME ON HIS ACCOUNT.. STILL SITTING AT A COMPUTER WRG BLK HOODED SWEATSHIRT
11110006	11/24/11 12:21	96	AUTR	11010069	
11110550	11/26/11 11:12	96	SUSC		PLOT
11111845	11/30/11 21:06	1059	HOOO		RP SAYS PATRONS FROM INTERNET CAFE ARE SMOKING HS BY THE DUMPSTER IN THE BACK PLOT.. RIGHT NOW MALE AND 2 FEMALES
11111949	12/1/11 8:54	94	WRNO		
11112557	12/2/11 22:01	UNK	SUSC		IN BACK PARKING LOT RP GOT A CALL FROM A SEC GUARD WHO IS 97 IN BACK PARKING LOT... SAID HE HAD SOMEONE IN CUFFS THEN THE PHONE DROPPED AND LINE WENT DEAD. RP IS 49 BUT REQUESTING PD ALSO
11113240	12/5/11 2:26	96	SUSC		
11116649	12/16/11 4:32		XPAT		
11118279	12/21/11 12:18		SUSC		
11119257	12/24/11 14:16		MSNF		
11120678	12/29/11 18:35	415	DRUN	11011304	

TOTAL # EVENTS 34

TOTAL # CASES 11

{EVENT_MAIN.ADDR_ST} = "A ST" and
 {EVENT_MAIN.ADDR_NUM} = "1908" and
 {EVENT_MAIN.RCV_TIME} in DateTime (2011, 08, 20, 00, 00, 00) to DateTime (2011, 12, 31, 23, 59, 59)

h:\Crystal Reports\CFS Reports\InternetCafes\CFS-Syn-1908A.rpt

Report is based on unaudited CAD/RMS data at time of report generation.
 Report for analysis purposes only - not for distribution - Law Enforcement Use Only

CALLS FOR SERVICE

1653 A ST

9/1/10 - 8/31/11

PRINTED:2/16/2012

<u>EVENT#</u>	<u>RCV TIME</u>	<u>CLASS</u>	<u>DISPO</u>	<u>CASE#</u>	<u>SYNOPSIS</u>
10089393	9/11/10 0:52	415F	ASLS		MALE AND FEMALE ON THE PHONE - BOTH SOUND INTOX OR ON H&S - SAYS PARKER, JOHN IS ON PAROLE AND GAVE THE FEMALE RP'S HUSB A LUMP ON HIS HEAD - AND NOW HE IS TRYING TO TAKE HIS VEH
10096584	9/30/10 22:35		NARC	10008553	
10096629	10/1/10 0:47	94	SUSC		
10103792	10/22/10 1:55		WRNO	10009178	
10110505	11/12/10 0:15	94	WRNO	10009842	
10111087	11/13/10 20:29	94	SUSC		
10112776	11/18/10 21:15	211A	ROBB	10010053	MALE W/BLK MASK, BLK HOODED SWEATSHIRT, BLK JEANS, JUST ROBBED MONEY FROM REGISTER, WAS ARMED W/SAW OFF SHOT GUN SHOT IT AT A CO WORKER, NO ONE HIT
10115832	11/28/10 19:36	488	THOF		IPOD STOLEN AND RP WANTS APD TO CK THEIR CAMERAS FOR THE RESP....OK TO SEND OFC PER C22
10116206	11/29/10 23:22	CIVI	CIVI		RP FOUND HER BLU PONT TRANSPORT VAN AT THE ABOVE LOCATION - RP SAYS HER DAUGHTER TOOK IT AND SHE IS STILL THERE - NOW A MALE IS THERE TRYING TO TAKE VEH FROM THE RP - VEH HAS DIABLO DEALER PAPER PLATES VIN [REDACTED]
10116816	12/1/10 20:52	94	SUSC		
10116863	12/1/10 23:25	95	VCOO		
10118970	12/8/10 23:48	PROM	PCOO		3 TO 4 SHOTS HEARD, NOTHING SEEN - SECURITY HAS INFO
10125571	12/30/10 19:54	96	VCOO		
11002393	1/8/11 21:01	488	THOF		THEFT OF CELL PH BY UNK RESP E # GIVEN
11008727	1/28/11 20:56	94	MSDS		ON 3
11008803	1/29/11 0:39	95	NARC	11000809	BLK HOND NP
11010169	2/2/11 11:26	HOOO	HOOO		[REDACTED] WORKS AT LOC AND HIS GIRLFRIEND [REDACTED] ARE BUYING AND SELLING DRUGS AT LOC....SHE SAYS HE SOMETIMES "CHEEKS" HIS DRUGS.....UNK IF THEY ARE THERE NOW OR NOT...RP SAYS [REDACTED] HAS TRACK MARKS ALL OVER HIS ARMS BUT WEARS LONG SLEEVED SHIRTS TO COVER THEM UP
11010329	2/2/11 21:45	94	SUSC		
11010370	2/3/11 1:06	94	VCOO		
11013060	2/10/11 23:00	96	VCOO		
11015349	2/18/11 0:51	95	VCOO		
11015870	2/19/11 20:48		SUPP		
11015889	2/19/11 22:23	95	VCOO		

<u>EVENT#</u>	<u>RCV TIME</u>	<u>CLASS</u>	<u>DISPO</u>	<u>CASE#</u>	<u>SYNOPSIS</u>
11016438	2/21/11 20:07	415F	MSDS		VERY LOUD VERBAL 2 HFS #1 WEARING PINK SHIRT GRY SWEATPANTS...
11016818	2/23/11 0:47	1059	XPAT		
11017471	2/25/11 1:47	95	NARC	11001604	
11020498	3/5/11 23:26	96	SUSC		
11023162	3/13/11 23:21	95	VCOO		
11024113	3/16/11 22:42	94	MSDS		
11025168	3/20/11 3:18	215	CARJ	11002337	10 AGO OCC NEAR AT 20TH/C RP JUST WALKED HERE TO CALL JAMIE UNK LAST NAME AND HER FRIEND HIT RP WITH A PIPE AND BBQ AN THEN TOOK RPS SIL FORD F350 KING CAB, UNK LIC REGISTERD TO [REDACTED] (RP NOT SURE OF SPELLING) MEDICAL REFUSED ALSO TOOK CELL [REDACTED]
11026661	3/25/11 1:59	FIRE	FDIC		VEH ON FIRE CUSTOMER INSIDE THE BUSN - NO ONE IN THE VEH / UNK WHAT HAPPENED.. XFERRED TO FIRE - ENR
11029305	4/1/11 23:32	94	SUPP		
11029757	4/3/11 2:34	95	VCOO		
11029765	4/3/11 3:00	95	VCOO		
11034055	4/16/11 2:20	95	VCOO		
11036122	4/21/11 21:46	96	SRVC		
11036157	4/21/11 23:31	96	PARK		
11036883	4/24/11 0:54	415	MALM		2 SUBJS CHASING EACH OTHER IN THE PARKING LOT, 1 IN A BLK NISS AND 1 IN A GREEN HONDA, PR ADV THE GREEN HONDA HIT A WHI CAD!
11038848	4/29/11 23:58		PARK		
11038890	4/30/11 1:59	94	SUSC		
11041791	5/8/11 1:28		WRAN	11003794	
11043128	5/12/11 1:11	95	VCOO		
11043224	5/12/11 10:02	94	WRNO	11003932	
11043239	5/12/11 10:53	94	SUSC		
11043876	5/13/11 23:23	95	VCOO		
11044017	5/14/11 10:32	94	SUSC		
11045926	5/20/11 3:02	1059	NARC	11004182	
11048426	5/27/11 14:11	94	SUSC		
11049360	5/30/11 9:38	SUSV	SUSC		MALE DRIVING THRU THE PL SEVERAL TIMES IN A BLK DURANGO...LS PARKED TRO OF RITE AIDE DRIVER WM C4
11050187	6/1/11 22:40	96	PARK		

<u>EVENT#</u>	<u>RCV TIME</u>	<u>CLASS</u>	<u>DISPO</u>	<u>CASE#</u>	<u>SYNOP</u>
11050220	6/2/11 0:36	PARK	PARK		
11050899	6/3/11 20:30	PARK	PARK		
11062140	7/5/11 22:53	27SUB	SUSC		RECD INFO THAT PAROLEE AT LARGE IS AT THIS LOC...RESP IS [REDACTED] UNK DOB.....RP HAS NFI. SUBJ IS NOT HIS PAROLEE AND HE HAS NFI.....NO BAIL CDC IN WPS W/4
11063231	7/9/11 0:40	94	SUSC		
11063642	7/10/11 2:41	314	EXPO		WF BLN HAIR ABOUT 24YO 504-505... STRIPPED DOWN NAKED IFO .. WAS WEARING A BLU MINI SKIRT.... FEM ARRIVED WITH A BM BLK HAT WHI SHIRT BLU SHORTS SAGGING BELOW HIS BUTTOCKS.. BOTH SUBJS HEAVILY INTOXICATED
11064952	7/14/11 1:57	10851R	AUTR	11005755	C5 ON UNOCCUPIED 10851
11065264	7/14/11 22:07	94	MSDS		94 ON 4
11065295	7/14/11 23:57	96	SUSC		
11067206	7/21/11 0:25	415	CARJ	11005954	SUBJ TRIED TO REPORT A GUY NAMED [REDACTED] JUST TOOK HIS VEH, BLK 2000 TOYT CAMRY LICTHEN 415 BROKE OUT OVER THE PHONE
11070675	7/31/11 10:26	95	SUPP		
11070676	7/31/11 10:32		AUTT	11006251	
11070678	7/31/11 10:38		AUTR		
11071782	8/3/11 20:09	HSOO	HSOO		ABOUT 6 SUBJS HANGING OUT IFO THE LOC, APPEAR TO BE USING HS
11071927	8/4/11 10:10	96	SUSC		
11072239	8/5/11 3:08	96	VCOO		
11073120	8/7/11 13:25	94	WRNO	11006430	WTH 1
11074887	8/12/11 18:11	94	SUSC		

TOTAL # EVENTS 67

TOTAL # CASES 14

{EVENT_MAIN.ADDR_NUM} = "1653" and
 {EVENT_MAIN.ADDR_ST} = "A ST" and
 {EVENT_MAIN.RCV_TIME} in DateTime (2010, 09, 01, 00, 00, 00) to DateTime (2011, 08, 31, 00, 00, 00)

h:\Crystal Reports\CFS Reports\InternetCafes\CFS-Syn-1653A.rpt

Report is based on unaudited CAD/RMS data at time of report generation.
 Report for analysis purposes only - not for distribution - Law Enforcement Use Only

CALLS FOR SERVICE

1836 A ST

2/1/10 - 8/30/10

PRINTED:2/16/2012

EVENT#	RCV TIME	CLASS	DISPO	CASE#	SYNOPSIS
10016711	2/19/10 15:10	5150	AIDX		PURSE MISSING FROM THE BINGO HALL NEAR THIS LOC RP HAS NO MAILING ADDRESS OR HOME SAYS SHE IS HOMELESS AND OUT OF OR ALMOST OUT OF HER MEDS FOR BIPOLAR,SUICIDAL TENDENCIES... PURSE WAS BRO MED SIZE WITH RPS TEETH,MEDS AND CADBURY EGGS INSIDE
10019077	2/26/10 19:47	94	SUSC		W/2
10021601	3/6/10 0:29	94	WRNO	10002054	
10030328	3/31/10 9:46	CAT	CATC		
10032897	4/8/10 0:37	94	WRNO	10003164	INT CAFE
10033045	4/8/10 13:49	415L	MSDS		WM TRANSIENT IFO THE BUSN ASKING FOR MONEY, NOT BOTHERING ANYONE BUT RP WOULD LIKE HIM MOVED ALONG WEARING OLD GRN ARMY JKT
10034163	4/11/10 17:32	SUSP	SUSC		BMA APPROX 20 LSW BEANIE WHI/BLU/RED JACKET KEEPS COMING INTO BUSN ACTING SUSP LS WALKING TWDS A ST
10034675	4/13/10 11:49	415V	SUSC		UNCOOPERATIVE RP SAYING SOMEONE IS TRYING TO FIGHT HIM OVER MONEY HE OWES RESP IS WMA 18-19 YO LONG BLN HAIR BLK SHIRT BLU JEANS ARRIVED ON FOOT
10045265	5/12/10 23:37	96	SUSC		
10046344	5/15/10 18:29	488	THOF		RPS CELL PHONE STOLEN FROM A MALE ...RP THINKS HES ON THE VIDEO
10047837	5/19/10 23:03	96	SUSC		
10048541	5/21/10 23:31	10851R	AUTR	10004654	UNOCC'D 10851
10050612	5/27/10 20:36	95	VCOO		GRAY CELICA NO PLATES
10050627	5/27/10 21:26	95	VCOO		
10053703	6/4/10 20:35	95	AUTS	10005105	
10056437	6/11/10 23:50	SUPP	SUPP		RP ADV SUSP IN JOES LIQUORS INCIDENT YESTERDAY IS A BM, THIN WEARING GLASSES, 99 CENT ONLY BAGS IN HIS HANDS..SUBJ WALKING TWDS INTERNET CAFE...OFC KIDD WAS LOOKING FOR THIS SUBJ PER THE RP
10059069	6/19/10 1:21	94	ASLS		
10061397	6/24/10 23:04		NARC	10005669	
10061417	6/25/10 0:35	94	ATMC		
10064092	7/2/10 1:14	96	SUSC		
10066477	7/7/10 22:05	95	VCOO		
10071603	7/22/10 22:52	94	HOO	10006488	
10071827	7/23/10 16:24	415D	ASLS	10006501	INSIDE BUSINESS MALE AND FEMALE YELLING AT EACH OTHER..NOW PHYSICAL..CAN HEAR THEM YELLING....BMA 27 YRS...506 180 LBS LONG SLEEVE GRY SHIRT.....BFA 30 YRS...BLK SHIRT...NO WEAPONS SEEN...NO INJURIES

<u>EVENT#</u>	<u>RCV_TIME</u>	<u>CLASS</u>	<u>DISPO</u>	<u>CASE#</u>	<u>SYNOPSIS</u>
10072022	7/24/10 1:21	96	VCOO		
10073649	7/28/10 22:01	96	SUSC		
10073978	7/29/10 21:25	94	PCOO		
10083767	8/26/10 22:12	94	VCOO		

TOTAL # EVENTS 27

TOTAL # CASES 7

{EVENT_MAIN.RCV_TIME} in DateTime (2010, 02, 01, 00, 00, 00) to DateTime (2010, 08, 30, 00, 00, 00) and
 {EVENT_MAIN.ADDR_NUM} = "1836" and
 {EVENT_MAIN.ADDR_ST} = "A ST"

h:\Crystal Reports\CFS Reports\InternetCafes\CFS-Syn-1836A.rpt

Report is based on unaudited CAD/RMS data at time of report generation.
 Report for analysis purposes only - not for distribution - Law Enforcement Use Only

CALLS FOR SERVICE
2333 BUCHANAN RD #A
9/1/11 - 2/15/12

PRINTED:2/16/2012

<u>EVENT#</u>	<u>RCV TIME</u>	<u>CLASS</u>	<u>DISPO</u>	<u>CASE#</u>	<u>SYNOPSIS</u>
11085380	9/11/11 10:52	33A	ALAF		BUSN CAUGHT ON THE WEB POA FRONT DOOR/ FRONT MOTION 7787004
12003100	1/10/12 20:36	95	NARC	12000344	C4
12005356	1/18/12 1:58	PARK	VCOO		
12008958	1/30/12 4:44	96	LOIT		
12009252	1/31/12 1:18	96	SUSC		
12011679	2/8/12 0:35		VCOO		

TOTAL # EVENTS 6

TOTAL # CASES 1

{EVENT_MAIN.ADDR_NUM} = "2333" and
{EVENT_MAIN.RCV_TIME} in DateTime (2011, 09, 01, 00, 00, 00) to DateTime (2012, 02, 15, 23, 59, 59) and
{EVENT_MAIN.ADDR_APT} = "A" and
{EVENT_MAIN.ADDR_ST} = "BUCHANAN RD"

h:\Crystal Reports\CFS Reports\InternetCafes\CFS-Syn-2333-A-Buchanan.rpt

Report is based on unaudited CAD/RMS data at time of report generation.
Report for analysis purposes only - not for distribution - Law Enforcement Use Only

ATTACHMENT "H"

SWEEPSTAKES GAMES RULES:

1. Game Rules are pursuant to California Business and Professions Code Sections, 17539.5, 17539.15 (amended September 30, 2008), and 17539.55.
2. Lucky Symbols™ Sweepstakes game chances CAN NOT BE PURCHASED OR SOLD.
3. **THERE IS NO PURCHASE OR PAYMENT NECESSARY TO PLAY LUCKY SYMBOLS™ SWEEPSTAKES.**
4. Any person over the age of eighteen (18) may request a free sweepstakes game chance. No solicitation is required or implied with this free offer with regard to free sweepstakes chances awarded in connection to the purchase of Internet Time Services. All game chances have the same "game chance" of winning a sweepstakes prize. Any person upon accepting a free sweepstakes game chance acknowledges and accepts the terms and conditions set forth in these Game Rules.
5. One free sweepstakes game chance per customer per business day is permitted inclusive of all participating Lucky Symbols™ Sweepstakes Game locations throughout the State of California. Legal name, current address, date of birth and phone number must be provided in writing to receive a free sweepstakes game chance. All personal information gathered will be kept confidential and will not be sold or used in any manner or condition other than to positively identify and keep record of all persons granted a free sweepstakes game chance.
6. All sweepstakes game prizes are redeemed and awarded on the same business. No exceptions considered or accepted. All unclaimed sweepstakes game prizes are considered forfeited by the player.
7. Sweepstakes Game Chances have no cash value and therefore cannot be sold or redeemed for cash or anything of value.
8. Sweepstakes Game Chances are obtained solely by the purchase of Internet Time Access to a live Browser web interlink site (s) on demand by the user. Internet Time Access is the only recognized tangible commodity sold and/or purchased.
9. Sweepstakes Game Chances are offered for the purpose of promoting increased sales of Internet Time Services Access.
10. The following classes of persons are not eligible to participate in the free sweepstakes game chances: present or former employees or agents of any Internet Time Access location engaged in the sale of Internet Time Services and offers Sweepstakes Game Chances to promote increased sales of Internet Time Services Access to the general public.
11. All played and winning and redeemed Sweepstakes Game Chance receipts remain to be the property of the game operator.
12. Sweepstakes Game Chance participants agree to release and hold harmless the game sponsor, its officers, members, employees, attorneys, affiliated organizations and agents, as well as the owners of any participating locations, and said owners' directors, officers, members, employees, attorneys, affiliated organizations and agents, from any and all claims, demands, liabilities, costs, expenses, penalties, damages (including incidental, consequential and punitive damages), injuries, death, losses of any kind, including, without limitation, reasonable attorney's fees, arising from or in connection with or that may result from their acceptance or use of a prize, their participation in the Sweepstakes Game Chances. Game participants agree not to dispute or contest the Sweepstakes Game Chances winning or losing outcomes. Participants accept responsibility for all federal, state and local taxes on any Sweepstakes Game prizes awarded to the winners.

GAME PRIZES AND ODDS OF WINNING:

1. The number of prizes awarded and the total value of all prize awarded to win depends on the total number of Sweepstakes Game Chances played. The more game chances played increases the player's odds of winning a prize. Some game prize's ratio of win will make some prizes a more frequent winning prize. All prizes are eligible to be a winning prize for any player. All prizes are awarded as a cash prize. Face value of each game prize are represented by the actual cash prize award amount assigned to that specific and separate game prize award. Example: A \$20.00 game prize can be redeemed for a twenty dollar (\$20.00) cash prize.

All game prizes must be redeemed on the same business day and must be redeemed at the same Sweepstakes Game operator location. No exceptions considered or accepted.

ATTACHMENT "I"

9-5.3816 MECHANICAL OR ELECTRONIC GAMES.

These are subject to the following regulations:

(A) Any proprietor owning or operating a business lawfully in existence on August 26, 1982, shall be deemed to have been issued a permit pursuant to this article, provided such proprietor, within 30 calendar days after said date, submits on a form prescribed by the City Manager a record of information on such existing business. No filing fee or permit fee shall be payable therefor. The provisions of this section shall apply to subsequent proprietors at the same location.

(B) Machines may be replaced without a change in such permit. In the event machines are added after August 26, 1982, to total more than three machines for the establishment, a use permit will be required under the provisions of this article.

(C) It shall be unlawful for any proprietor to install, operate, or maintain to be operated any mechanical or electronic game without first having obtained a use permit. The permit shall be conspicuously posted at the location of the games in the premises and shall not be removed during the period for which the license was issued. In cases where the mechanical or electronic games occupy more than 50% of the premises' customer floor space, or account for 50% or more of the premises' gross revenue, or where 10 or more such games are proposed, the use permit shall be referred to the Council for final approval pursuant to the provisions of this article. The use permit shall state the number of games, and the use of additional games shall require a new or modified use permit.

(D) No operator shall install or allow any mechanical or electronic game to be installed in any proprietor's place of business which game requires a permit as provided for in this article unless such proprietor has been issued such permit.

(E) Applicants for use permits shall undergo a background check by the Police Department. The permit may be denied if the applicant has been convicted of a crime which has relevance to the operation of the premises.

(F) No such use permit shall apply to any premises other than the location originally approved. Upon change of ownership, the new owner shall receive clearance from the Police Department; however, no other use permit proceedings shall be required for such transfer if the new owner received police clearance.

(G) The permit provided for in this article may be revoked or suspended as provided for in this chapter. In addition, the violation of any provision of this article shall be grounds for revocation or suspension.

(H) The following shall be considered as standard use permit conditions which can be used as the basis for use permit revocation or suspension:

(1) There shall be adult supervision during the hours of operation.

(2) There shall be no minors consuming alcohol on the premises.

(3) There shall be no use, sale, exchange, or presence of drugs or other illegal substances on the premises.

(4) Patrons shall not become a nuisance to the properties within the immediate vicinity.

(I) It shall be unlawful for any proprietor of a mechanical or electronic game to cause, permit, or allow such game to be located, operated, or maintained to be operated within 1,000 feet of the nearest street entrance to or exit from any public playground or public or private school of elementary or high school grades, such distance to be measured from such entrance or exit in the most direct line or route on, along, or across such street or streets adjacent to such public playground or public or private school of elementary or high school grade. The restrictions established by this section shall not apply to businesses lawfully in existence and operating on August 26, 1982.

(J) It shall be unlawful for any proprietor or employee to allow any minor under 18 years of age to play or use any such games during the academic year for public schools in the city, except during school holidays and on Saturdays and Sundays, and between the hours of 7:00 a.m. and 10:00 p.m. on all days preceding school days and between 7:00 a.m. and 11:00 p.m. on all other days.

(K) This article shall not apply to the following:

(1) Any operation involving three or fewer mechanical or electronic games, except where such games provide the main or primary source of income for the proprietor thereof;

(2) The operation or maintenance of such games within recreational enterprises, such as bowling alleys or poolrooms, where a use permit has already been obtained; and

(3) Premises or operations licensed by the Department of Alcoholic Beverage Control of the State for on-sale consumption of alcoholic beverages, excepting therefrom any such premises or operations which lawfully permit minors, such as bona fide public eating places.

ATTACHMENT "J"



January 5, 2012

Will Beaubien
Beaubien Investment Group
One Market Street
Spear Tower, Suite 3600
San Francisco, CA 94105

Patricia Cooper-Simmons
T's Internet Café
3127 Sunflower Drive
Antioch, CA 94531

**Re: T's Internet Café
522 West 2nd Street, Antioch (APN 066-051-006)**

Dear Mr. Beaubien and Ms. Cooper-Simmons:

The City of Antioch understands that the business operating as T's Internet Café falls under the regulations contained in Section 9-5.3816 of the Antioch Municipal Code relating to Mechanical and Electronic Games, attached in its entirety. Subsection (I), pasted below, specifically regulates locations of said businesses. The building at 522 West 2nd Street, Antioch (APN 066-051-006) is located with 1,000 feet of a public school. Therefore, a Use Permit for Mechanical and Electronic gaming cannot be accepted and the use cannot be approved.

- (I) It shall be unlawful for any proprietor of a mechanical or electronic game to cause, permit, or allow such game to be located, operated, or maintained to be operated within 1,000 feet of the nearest street entrance to or exit from any public playground or public or private school of elementary or high school grades, such distance to be measured from such entrance or exit in the most direct line or route on, along, or across such street or streets adjacent to such public playground or public or private school of elementary or high school grade. The restrictions established by this section shall not apply to businesses lawfully in existence and operating on August 26, 1982.

Staff has observed contractors working at the above address without a Building Permit. A Stop Work Notice was given today. A Building Permit will not be issued for T's Internet Café as the use is not permitted.

I can be reached at 779.7038 or twehrmeister@ci.antioch.ca.us should you have questions.

Sincerely,

A handwritten signature in cursive script that reads "Tina Wehrmeister".

Tina Wehrmeister
Community Development Director

Community Development Department

P.O. Box 5007 • 200 H Street • Antioch, CA 94531-5007 • Tel: 925-779-7035 • Fax: 925-779-7034 • www.ci.antioch.ca.us

J1

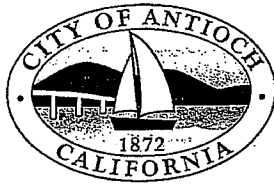

NOTICE OF VIOLATION OF THE ANTIOCH MUNICIPAL CODE
MECHANICAL OR ELECTRONIC GAMES

January 10, 2012

Patricia Simons
Cot on the Web
2333 Buchanan Road, #A
Antioch, CA 94509

Patricia Simons
3127 Sunflower Drive
Antioch, CA 94531

Parcel No. 076-432-014
Address: 2333 Buchanan Road, #A, Antioch, CA

The City of Antioch understands that the business operating as Cot on the Web falls under the regulations contained in Section 9-5.3816 of the Antioch Municipal Code relating to Mechanical and Electronic Games, attached in its entirety. Section 9-5.3816(C) states:

It shall be unlawful for any proprietor to install, operate, or maintain to be operated any mechanical or electronic game without first having obtained a use permit.

The City does not have record of your business obtaining a Use Permit. You are required to submit a Use Permit application by January 30, 2012. An application is attached for your convenience.

The City is providing this one-time opportunity to voluntarily abate the above violation(s) and public nuisance without the need for the City to issue Administrative Citations, which carry fines that range from \$100 to \$1,000 for every day the violation(s) are permitted to remain and/or take other action to compel your compliance.

Thank you in advance for your cooperation in abating these violation(s). If you have any questions, you may contact me at (925) 779-7038 or twehrmeister@ci.antioch.ca.us.

Sincerely,

Tina Wehrmeister
Community Development Director

cc: June Patricia Smoot
Jeffery & Carolyn McClung



NOTICE OF VIOLATION OF THE ANTIOCH MUNICIPAL CODE
MECHANICAL OR ELECTRONIC GAMES

James Hayes
Rapid Business Solutions
2962 Delta Fair Blvd
Antioch, CA 94509

January 18, 2012

Parcel No. 076-440-031
Address: 2962 Delta Fair Blvd., Antioch, CA

The City of Antioch understands that the business operating as Rapid Business Solutions falls under the regulations contained in Section 9-5.3816 of the Antioch Municipal Code relating to Mechanical and Electronic Games, attached in its entirety. Section 9-5.3816(C) states:

It shall be unlawful for any proprietor to install, operate, or maintain to be operated any mechanical or electronic game without first having obtained a use permit.

The City does not have record of your business obtaining a Use Permit. You are required to submit a Use Permit application by January 30, 2012. An application is attached for your convenience.

The City is providing this one-time opportunity to voluntarily abate the above violation(s) and public nuisance without the need for the City to issue Administrative Citations, which carry fines that range from \$100 to \$1,000 for every day the violation(s) are permitted to remain and/or take other action to compel your compliance.

Thank you in advance for your cooperation in abating these violation(s). If you have any questions, you may contact me at (925) 779-7038 or twehrmeister@ci.antioch.ca.us.

Sincerely,

Tina Wehrmeister
Community Development Director

cc: Chiu Family LLC

ATTACHMENT "K"



GagenMcCoy

William E. Gagen, Jr.
Gregory L. McCoy
Patrick J. McMahon
Charles A. Koss
Michael J. Markowitz
Richard C. Raines
Barbara Duval Jewell
Robert M. Fanucci
Allan C. Moore
Stephen T. Buehl
Amanda Bevins
Martin Lysons
Lauren E. Dodge
Sarah S. Nix
Ross Pytlik
Brian P. Mulry
Amanda Beck

Of Counsel
Linn K. Coombs

The Law Offices of
**Gagen, McCoy, McMahon, Koss
Markowitz & Raines**
A Professional Corporation

Danville Office
279 Front Street
P.O. Box 218
Danville, California 94526-0218
Telephone: (925) 837-0585
Fax: (925) 838-5985

Napa Valley Office
The Offices At Southbridge
1030 Main Street, Suite 212
St. Helena, California 94574
Telephone: (707) 963-0909
Fax: (707) 963-5527

February 6, 2012

Please Reply To:
Danville



By Email and Hand-Delivery
February 6, 2012
Board of Administrative Appeals
City of Antioch
Chair Frederick Rouse
c/o City Clerk
200 "H" Street
Antioch, CA 94509

Re: City Notice of Violation dated January 18, 2012
Rapid Business Solutions/2962 Delta Fair Boulevard, Antioch (APN 076-440-031)
Administrative Appeal

Dear Chair Rouse, Board members, and City Clerk:

Our office represents James Hayes, owner and operator of Rapid Business Solutions, located at 2962 Delta Fair Boulevard in Antioch (the Internet café), with regard to the City of Antioch's Notice of Violation dated January 18, 2012.

The City's Notice of Violation states that the business (Internet café) operating as Rapid Business Solutions falls within the City's Municipal Code at §9-5.3816, relating to "Mechanical and Electronic Games." The Notice of Violation states that the Internet café is therefore required to submit a Use Permit application by January 30, 2012.¹

¹ By email exchange, City staff extended the response date to February 6, 2012. Our office further held an informal meeting with Staff on February 2, 2012, and confirmed our Appeal or other response would be filed on/before February 6, 2012.

Please consider this letter a Notice of Appeal of the administrative decision to take the proposed action. (We are filing this Notice of Appeal in anticipation of the City moving forward to take action as outlined in the City's Notice of Violation. If the City does not take such action, and/or if the City will work with us as outlined below, we will withdraw the Notice of Appeal.)

Mr. Hayes wants to work with the City and to continue to be a good neighbor to all adjacent businesses and the greater Antioch community. We understand and appreciate the City's desire to ensure that all businesses comply with the City's ordinances and do not create a nuisance, an increase in vandalism, or any similar land use impacts. We want to cooperate with the City on any such issue as it relates to the Internet café, including increased security, etc., and we will commit to working with the City.

Having stated the above, we hereby appeal the City's potential action (to require a Use Permit or to issue Administrative Citations), based on several grounds, including the following.

1. Applicability of §9-5.3816

The City's Municipal Code at §9-5.3816 is entitled "Mechanical or Electronic Games." Section (C) states as follows:

It shall be unlawful for any proprietor to install, operate or maintain any mechanical or electronic game without first having obtained a use permit . .

The City's Municipal Code defines "Mechanical or Electronic Games" in its Definitions section, at §9-5.203, as follows:

Any machine, apparatus, contrivance, appliance, or device which may be operated or played upon the placing or depositing therein of any coin, check, slug, ball, or any other article or device, or by paying therefore either in advance of or after use, involving in its use either skill or chance, including, but not limited to, a tape machine, pinball machine, bowling game machine, shuffleboard machine, marble game machine, horse racing machine, basketball game machine, baseball game machine, football game machine, electronic video game, or any other similar machine or device.

We note that §9-5.3816 as referenced above relates back to businesses operating as of August 26, 1982. At that time, there was no such thing as "Internet cafes" as they are known today. As set forth below, Internet cafes, Cybercafes and related businesses provide access to the Internet, which is recognized as an activity afforded special protection under the First Amendment.

We do not believe the City's §9-5.3816 was intended to apply to the Internet, and we do not believe the business activities and facilities (including the computers and related facilities) of Mr. Hayes' Internet café fall within the definition of §9-5.203.

2. City Requirement for a Use Permit

The City's Notice of Violation indicates it intends to require that the subject ongoing business (the Internet café) obtain a Use Permit. The City's Municipal Code at §9-5.2703 (B)(1) requires certain findings for the issuance of a Use Permit, including:

"That the granting of such [Use Permit] will not be detrimental to the public health or welfare ..."

California Appellate cases and authorities state that the discretion of local agencies to require an applicant to obtain a Use Permit is severely limited when First Amendment rights are implicated. This is particularly the case for businesses which provide access to the Internet.

In *Vo v. City of Garden Grove* (115 Cal. App. 4th 425 (2004)), the City of Garden Grove adopted an emergency interim ordinance and a moratorium against new CyberCafes. The ordinance required existing Cybercafes to apply for a Use Permit by a certain date. *The Court held such Use Permit requirement to be invalid.* In its decision, the Court noted that the City's Use Permit ordinance gave the City broad discretion to deny the Use Permit if the use impacts the "public health, safety or general welfare" (*the same criteria in the City of Antioch's ordinance*). The Court found that Garden Grove's Use Permit process gave the City too much discretion to restrict First Amendment rights.

For these and related reasons, we respectfully believe that the City should not impose a Use Permit requirement on Mr. Hayes' existing Internet cafe business. However, as noted above, we do want to work with the City with regard to reasonable steps we can agree on to address legitimate ongoing City concerns.

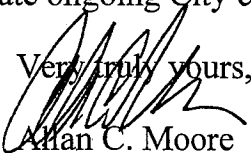
Very truly yours,

Allan C. Moore

cc: Tina Wehrmeister
Director of Community Development Department

Lynn Tracy Nerland
City Attorney

James Hayes

GAGEN, McCOY, McMAHON, KOSS, MARKOWITZ & RAINES
A PROFESSIONAL CORPORATION
ATTORNEYS AT LAW
279 FRONT STREET
DANVILLE, CA 94526
PHONE (925) 837-0585

103546



90-2267-1211

2/6/2012

PAY Fifty & No/100 Dollars

50.00

GAGEN, McCOY, McMAHON, KOSS, MARKOWITZ & RAINES
TWO SIGNATURES REQUIRED OVER \$1,000.00 DOLLARS

AUTHORIZED SIGNATURE

TO THE
ORDER
OF
City of Antioch

⑈ 103546 ⑆ 121122676 ⑆ 153453447705 ⑈

Security features. Details on back.

K4

1/23/11

I am appealing letter sent to Cot On The Web 2223a Buchanan rd Antioch CA 94509. It states that I need to get an arcade permit for the sale of internet time I am not a arcade in any way and do not sell anything but internet time.

Any questions

Patricia Simmons

925-209-8332

3127 Sunflower
Antioch CA 94531

Aeventtoremember@Comcast.net

CITY OF ANTIOCH
925-779-7055

RECH: 00477860 1/24/2012 12:13 PM
OPER: FV3 TERM: 003
REFN:

TRAN: 132.0000 Other Sv Chg-Copies
APPEAL FOR COT ON THE WEB
Other Service Chgs 50.00CR

TENDERED: 50.00 CASH
APPLIED: 50.00-

CHANGE: 0.00

 ORIGINAL

RECEIVED

JAN 24 2012

CITY OF ANTIOCH
CITY CLERK

K5

1-12-12

To: The city of Antioch

I Am Appealing letter Received 1-5-12
by Tina Wehmeister stating My Sales of
Internet Time/Phone Cards ARE Electronic
Games. T's internet cafe Does Not Sell
Any kind of Game At All. I Do Not
Feel A Electronic Game Permit is Needed
for T's internet cafe

Thank
you

Patricia Simmons

T's internet cafe

925-209-8332

RECEIVED

JAN 12 2012

CITY OF ANTIOCH
CITY CLERK

CITY OF ANTIOCH
925-779-7055

REQ#: 00475867 1/12/2012 10:29 AM
OPER: FV3 TERM: 003
REF#:

TRAN: 132.0000 Other Sv Chg-Copies
PATRICIA SIMMONS
Other Service Chrg: 50.00CR

TENDERED: 60.00 CASH
APPLIED: 50.00-

CHANGE: 10.00

K6

**STAFF REPORT TO THE CITY COUNCIL FOR CONSIDERATION AT THE
COUNCIL MEETING OF FEBRUARY 28, 2012**

FROM: Lynn Tracy Nerland, City Attorney *LTN*

DATE: February 22, 2012

**SUBJECT: Ballot Measure to Make the Offices of City Clerk and City Treasurer
Appointed**

ACTION ITEMS: Following the City Council's direction at its meeting on February 14, 2012, the following item is before the City Council for consideration, including the decision points outlined below under "Election Process":

1. Resolution calling a Special Municipal Election on June 5, 2012 for the submission to the voters of a local ballot Measure to make the Offices of City Clerk and City Treasurer appointed and requesting that the Board of Supervisors of Contra Costa County to consolidate a Municipal Election on a local measure with other elections to be held on the June 5, 2012 Regular Election (Attachment A)

If the City Council would prefer to separate the questions on the City Clerk and City Treasurer, as discussed in the "Options" section below, then two separate resolutions have also been prepared (Attachments B and C)

BACKGROUND:

At the February 14, 2012 City Council meeting, the City Council voted unanimously to submit a ballot measure to the voters at the June 5, 2012 election whether to make the elected City Clerk and City Treasurer positions appointed, because the traditional duties of these part-time offices are increasingly handled by professional staff and consultants given the expertise required and the cost savings if not paying a salary stipend or benefits to these officers.

Offices of City Clerk and City Treasurer

State law requires a general law city, like Antioch, to have a City Clerk and City Treasurer. The positions may be elected or appointed. In Antioch, the positions are currently elected to four-year terms with both terms expiring in November 2012. Of California's approximately 480 cities in 2010, only 157 cities had an elected city clerk and 173 cities had an elected city treasurer. Oakley and Brentwood both have appointed city clerks and city treasurers. In 2008, Concord voters made the city clerk position appointed and will be considering whether to do the same for the city treasurer position this year.

The only qualifications in state law for the elected city clerk or elected city treasurer positions are that the individual is over 18 years of age; a resident of Antioch; a registered voter in Antioch; and not convicted of certain crimes that disqualify a person from holding public office (e.g. conflicts of interest in contracts, embezzlement of public money, bribery, forgery, etc.). There is no process established in state law for confirming that these qualifications are met, presumably assuming that the election process would vet these issues.

With an elected City Clerk and City Treasurer positions, state law requires the electorate to vote to change them to an appointed position. If the measure is successful, then the City Council can establish qualifications for education, certification and experience for the positions. The appointment can be an existing staff member at current salary. For example, it is common that a finance director is often given the title "City Treasurer" as well. Alternatively, the City Council could by ordinance delegate to the City Manager the authority to appoint these officers.

The duties of the current City Clerk and City Treasurer were outlined in detail in the staff report for the February 14, 2012 meeting:
(<http://ci.antioch.ca.us/CityGov/agendas/CityCouncil/2012/agendas/021412/021412.pdf>)
In summary, with the transfer of certain financial and accounting duties to the Finance Director and taxing duties to the County, the statutory duties of the Antioch City Clerk under the California Government Code are limited to keeping a record of the Council meetings; keeping certified copies of ordinances; being custodian of the City's seal; and administering oaths of office and other oaths. (Cal. Gov't Code sections 40801 et seq.) The current understanding of the duties of the elected City Clerk position is to: attend Council meetings; oversee the taking of minutes at Council meetings; prepare announcements of openings on City Commissions and Boards; prepare proclamations and certificates; and preside over ceremonial functions. Staff handles the other duties of the Office.

The elected City Treasurer here in Antioch has the following duties: review the City's Investment Policy annually and prepare an update for City Council approval, if there are changes to state law or recommendations from the City's investment manager; sign the monthly treasurer's report submitted to the City Council, which is prepared by City staff; maintain field checks and review all registers from departments; review weekly checks issued; and if there are any assessment district payoffs, then collect those and gives them to the Finance Department (much rarer with the current housing market). The City Treasurer has recently indicated that these tasks require less than one day of her time every other week. Other duties of the City Treasurer position are handled by the Finance Department.

Ballot Measure Language

With an elected City Clerk and/or City Treasurer position, California Government Code section 36509 requires the electorate to vote to change it to an appointed position with the ballot question substantially in one of the following forms:

Shall the offices of city clerk and city treasurer be appointive?
Shall the office of city clerk be appointive?
Shall the office of city treasurer be appointive?

Staff recommends using the word “appointed” instead of “appointive” given its more common usage now but still being substantially in the form of the question mandated by state law.

The City Council has directed that a single ballot measure be put to the electorate at the June 5, 2012 primary which requires resolutions to be submitted by February 29, 2012. If the Council now desires to separate the measures resolutions are discussed under “Options” section and attached (Attachments B and C)

Election Process

With a ballot measure placed before the voters, the City Council needs to make a number of decisions that would be memorialized in the adopted resolutions sent to the County Elections Department (Attachments A and B)

- **Argument in favor of the ballot measure: Will the City Council authorize the filing of the argument in support of the ballot measure? Is the Mayor, Mayor Pro Tem or other Council Member authorized to actually file the ballot measure?** If this is not done and there are multiple arguments submitted, then the California Elections Code has a hierarchy to allow the elections official to determine which argument is included in the voter information pamphlet for each position. Under state law, each argument cannot exceed 300 words in length. The deadline for the submittal of arguments for or against the measure is **5:00 p.m. Thursday, March 8, 2012.**

The City Council can also authorize the filing of an argument opposed to the ballot measure.

- **Signatories to the argument in favor of the ballot measure: Does the City Council want to submit the argument in support of the ballot measure as the 1) “Antioch City Council”; or 2) have each City Council Member sign the argument; or 3) task the Mayor or a Council Member with obtaining appropriate signatories who may not all be City Council Members?** No more than 5 signatures can appear with the argument.

With the sales tax measure in 2011, the Mayor and Mayor Pro Tem were both authorized to file the written argument in support of the ballot measure and obtain the signatures to appear with the argument. It was determined that a representative group of individuals would sign the measure.

- **Rebuttal Arguments.** **Does the City Council want to prohibit rebuttal arguments?** This has been the practice in the past, in part due to the additional costs with the printing. In addition, timing issues with the County Elections Department occur with rebuttal arguments given the late date of filing the measure.

The resolutions also provide that the measure is to be transmitted to the City Attorney to prepare the Impartial Analysis pursuant to California Elections Code section 9280, which is also submitted to the voters with the ballot measure. The Impartial Analysis must be submitted no later than 5:00 p.m. on Thursday, March 8, 2012.

The City Clerk's Office will also be required to prepare and publish the consolidated "Notice of Election; Synopsis of the Measure and Notice to File Arguments."

FISCAL IMPACT:

The Contra Costa County Elections Division estimates the cost of a ballot measure at the June 5, 2012 election to be \$2.50 per registered voter with Antioch having approximately 42,000 registered voters. There would be an incremental cost for additional ballot measures, estimated by the County to be approximately \$0.25 per registered voter. Therefore, the cost of one ballot measure on the June 2012 election is approximately \$105,000 with the cost of two ballot measures approximately \$115,500. These costs are substantially less than holding a special election that is not consolidated with another statewide election.

The City Clerk and City Treasurer receive the same salary and car allowance that a member of the City Council receives and may also receive benefits if eligible. The approximate annual cost of the salary and benefits for each elected position ranges from \$12,000 to \$20,000, depending on whether the person is eligible for and receives benefits (e.g. medical insurance, life insurance, etc.).

In addition, the City would save approximately \$ 12,000 every four years in election costs for each position in not having these positions on the ballot (based on the November 2008 election costs).

OPTIONS:

Rather than ask the compound question of both the City Clerk and City Treasurer positions becoming appointed, two separate questions can be asked:

Shall the office of city clerk be appointive?

Shall the office of city treasurer be appointive?

As noted above, there is an incremental cost for additional ballot measures estimated by the County to be approximately \$0.25 per registered voter. Therefore, the cost of one ballot measure on the June 2012 election is approximately \$105,000 with the cost of two ballot measures approximately

\$115,500.

ATTACHMENTS:

- A. Resolution calling a Special Municipal Election on June 5, 2012 for the Submission to the Voters of a Local Ballot Measure to make the Offices of City Clerk and City Treasurer appointed and requesting that the Board of Supervisors of Contra Costa County to Consolidate a Municipal Election on a Local Measure with Other Elections to be held on the June 5, 2012 Regular Election
- B. Resolution calling a Special Municipal Election on June 5, 2012 for the Submission to the Voters of a Local Ballot Measure to make the Office of City Clerk appointed and requesting that the Board of Supervisors of Contra Costa County to Consolidate a Municipal Election on a Local Measure with Other Elections to be held on the June 5, 2012 Regular Election
- C. Resolution calling a Special Municipal Election on June 5, 2012 for the Submission to the Voters of a Local Ballot Measure to make the Office of City Treasurer appointed and requesting that the Board of Supervisors of Contra Costa County to Consolidate a Municipal Election on a Local Measure with Other Elections to be held on the June 5, 2012 Regular Election

RESOLUTION NO. 2012/

**RESOLUTION OF THE CITY COUNCIL OF THE CITY OF ANTIOCH
CALLING FOR A MUNICIPAL ELECTION TO SUBMIT TO THE VOTERS
A LOCAL BALLOT MEASURE TO MAKE THE OFFICES OF
CITY CLERK AND CITY TREASURER APPOINTED
AND REQUESTING THE BOARD OF SUPERVISORS OF CONTRA COSTA COUNTY
TO CONSOLIDATE A MUNICIPAL ELECTION ON A LOCAL MEASURE
WITH OTHER ELECTIONS TO BE HELD ON THE JUNE 5, 2012
REGULAR ELECTION DATE**

WHEREAS, a primary election is scheduled for June 5, 2012; and

WHEREAS, the City Council deems it advisable to submit to the voters a ballot measure to make the offices of city clerk and city treasurer appointed instead of elected because the traditional duties of these part-time offices are increasingly handled by professional staff and consultants given the expertise required and the cost savings if not paying a salary stipend or benefits to the officers;

WHEREAS, the City Council is authorized to request an order that the ballot measure election be consolidated with other elections to be held on the same day and in the same territory (California Elections Code 10400 *et seq.*); and

WHEREAS, it is desirable that said ballot measure election be consolidated with the June 5, 2012 primary election; that within the City, the precincts, polling places, and election officers for the two elections be the same; that the Board of Supervisors canvass the returns of the City ballot measure election; and said City ballot measure election be held in all respects as if there were only one election;

NOW, THEREFORE, BE IT RESOLVED BY THE CITY COUNCIL OF THE CITY OF ANTIOCH:

1. **Call for Election.** The City Council hereby calls an election on Tuesday, June 5, 2012 for the purpose of submitting to the voters a ballot measure to make the offices of city clerk and city treasurer appointed instead of elected. A majority vote is required for the passage of the ballot measure.

2. **Form of Measure.** The text of the proposed ordinance to be submitted to the voters is attached as Exhibit A to this resolution. The exact form of the measure to be voted upon shall appear on the ballot as follows:

CHANGING THE CITY CLERK AND CITY TREASURER POSITIONS FROM ELECTED TO APPOINTED. Shall the offices of city clerk and city treasurer be appointed?	YES	
	NO	

The measure shall be designated on the ballot by a letter printed on the left margin of the square containing the description of the measure, as provided in California Election Code section 13116.

3. Transmission to the City Attorney. The City Clerk is directed, pursuant to Elections Code section 9280, to transmit a copy of the measure to the City Attorney for the purpose of preparing an impartial analysis of the measure to be submitted no later than 5:00 p.m. on Thursday, March 8, 2012.

4. Full Text of the Measure. The ballot measure question as set forth above is the full text of the measure.

5. Argument For the Measure. The City Council authorizes _____ to file the written primary argument in support of the ballot measure described above pursuant to Article 4 of Chapter 3 of Division 9 of the California Elections Code. Signatories to the argument shall be _____. Arguments for or against the measure shall be no longer than 300 words in length.

6. Date for Submission of Arguments. The City Clerk, with the concurrence of the County Elections Official, has fixed 5:00 p.m. Thursday, March 8, 2012 as the deadline for submittal of arguments for or against the measure.

7. Rebuttal Arguments. No rebuttal arguments shall be allowed.

8. Consolidation of Election. The City Council requests and consents that the Board of Supervisors of the County of Contra Costa, State of California order the consolidation of the election in the City of Antioch to be held on June 5, 2012, with any other election(s) to be held on the same regular election date, under California Election Code sections 10400 *et seq.*

9. Conduct of the Election. The consolidated election shall be held and conducted, election officers appointed, voting precincts designated, ballots printed, polls opened and closed, ballots counted and returned, returns canvassed, results declared, certificates of election issued, and all other proceedings incidental to and connected with the election shall be regulated and done by the County Clerk in accordance with the provisions of law regulating a regularly scheduled election. The Board of Supervisors is hereby requested to issue all officers of the

County charged with duties pertaining to the June 2012 election instructions to take any and all steps necessary for the holding of such consolidated election. (California Elections Code 10418.)

10. Costs. The City will reimburse the County for the actual cost incurred in conducting the election upon receipt of a bill stating the amount due as determined by the Election Official

11. Boundaries. The boundaries of the City have not changed since the November 2010 election.

12. Filing with County. The City Clerk is directed to file with the Board of Supervisors and the County Clerk of Contra Costa County certified copies of this resolution.

13. Filing the Notice. Pursuant to Elections Code section 9163 and 12111, the City Clerk's Office shall publish the required notice in a newspaper of general circulation in the City of Antioch.

* * * * *

I HEREBY CERTIFY that the foregoing resolution was passed and adopted by the City Council of the City of Antioch at a regular meeting thereof, held on the 28th day of February 2012, by the following vote:

AYES: Councilmembers

NOES:

ABSENT:

CITY CLERK , CITY OF ANTIOCH

CHANGING THE CITY CLERK AND CITY TREASURER POSITIONS FROM ELECTED TO APPOINTED. Shall the offices of city clerk and city treasurer be appointed?

RESOLUTION NO. 2012/

**RESOLUTION OF THE CITY COUNCIL OF THE CITY OF ANTIOCH
CALLING FOR A MUNICIPAL ELECTION TO SUBMIT TO THE VOTERS
A LOCAL BALLOT MEASURE TO MAKE THE OFFICE OF
CITY CLERK APPOINTED
AND REQUESTING THE BOARD OF SUPERVISORS OF CONTRA COSTA COUNTY
TO CONSOLIDATE A MUNICIPAL ELECTION ON A LOCAL MEASURE
WITH OTHER ELECTIONS TO BE HELD ON THE JUNE 5, 2012
REGULAR ELECTION DATE**

WHEREAS, a primary election is scheduled for June 5, 2012; and

WHEREAS, the City Council deems it advisable to submit to the voters a ballot measure to make the office of city clerk appointed instead of elected because the traditional duties of this part-time office are increasingly handled by professional staff and consultants given the expertise required and the cost savings if not paying a salary stipend or benefits to the officer;

WHEREAS, the City Council is authorized to request an order that the ballot measure election be consolidated with other elections to be held on the same day and in the same territory (California Elections Code 10400 *et seq.*); and

WHEREAS, it is desirable that said ballot measure election be consolidated with the June 5, 2012 primary election; that within the City, the precincts, polling places, and election officers for the two elections be the same; that the Board of Supervisors canvass the returns of the City ballot measure election; and said City ballot measure election be held in all respects as if there were only one election;

NOW, THEREFORE, BE IT RESOLVED BY THE CITY COUNCIL OF THE CITY OF ANTIOCH:

1. Call for Election. The City Council hereby calls an election on Tuesday, June 5, 2012 for the purpose of submitting to the voters a ballot measure to make the office of city clerk appointed instead of elected. A majority vote is required for the passage of the ballot measure.

2. Form of Measure. The text of the proposed ordinance to be submitted to the voters is attached as Exhibit A to this resolution. The exact form of the measure to be voted upon shall appear on the ballot as follows:

CHANGING THE CITY CLERK POSITION FROM ELECTED TO APPOINTED. Shall the office of city clerk be appointed?	YES	
	NO	

The measure shall be designated on the ballot by a letter printed on the left margin of the square containing the description of the measure, as provided in California Election Code section 13116.

3. Transmission to the City Attorney. The City Clerk is directed, pursuant to Elections Code section 9280, to transmit a copy of the measure to the City Attorney for the purpose of preparing an impartial analysis of the measure to be submitted no later than 5:00 p.m. on Thursday, March 8, 2012.

4. Full Text of the Measure. The ballot measure question as set forth above is the full text of the measure.

5. Argument For the Measure. The City Council authorizes _____ to file the written primary argument in support of the ballot measure described above pursuant to Article 4 of Chapter 3 of Division 9 of the California Elections Code. Signatories to the argument shall be _____. Arguments for or against the measure shall be no longer than 300 words in length.

6. Date for Submission of Arguments. The City Clerk, with the concurrence of the County Elections Official, has fixed 5:00 p.m. Thursday, March 8, 2012 as the deadline for submittal of arguments for or against the measure.

7. Rebuttal Arguments. No rebuttal arguments shall be allowed.

8. Consolidation of Election. The City Council requests and consents that the Board of Supervisors of the County of Contra Costa, State of California order the consolidation of the election in the City of Antioch to be held on June 5, 2012, with any other election(s) to be held on the same regular election date, under California Election Code sections 10400 *et seq.*

9. Conduct of the Election. The consolidated election shall be held and conducted, election officers appointed, voting precincts designated, ballots printed, polls opened and closed, ballots counted and returned, returns canvassed, results declared, certificates of election issued, and all other proceedings incidental to and connected with the election shall be regulated and done by the County Clerk in accordance with the provisions of law regulating a regularly scheduled election. The Board of Supervisors is hereby requested to issue all officers of the

County charged with duties pertaining to the June 2012 election instructions to take any and all steps necessary for the holding of such consolidated election. (California Elections Code 10418.)

10. Costs. The City will reimburse the County for the actual cost incurred in conducting the election upon receipt of a bill stating the amount due as determined by the Election Official

11. Boundaries. The boundaries of the City have not changed since the November 2010 election.

12. Filing with County. The City Clerk is directed to file with the Board of Supervisors and the County Clerk of Contra Costa County certified copies of this resolution.

13. Filing the Notice. Pursuant to Elections Code section 9163 and 12111, the City Clerk's Office shall publish the required notice in a newspaper of general circulation in the City of Antioch.

* * * * *

I HEREBY CERTIFY that the foregoing resolution was passed and adopted by the City Council of the City of Antioch at a regular meeting thereof, held on the 28th day of February 2012, by the following vote:

AYES: Councilmembers

NOES:

ABSENT:

CITY CLERK , CITY OF ANTIOCH

CHANGING THE CITY CLERK POSITION FROM ELECTED TO APPOINTED. Shall the office of city clerk be appointed?

RESOLUTION NO. 2012/

**RESOLUTION OF THE CITY COUNCIL OF THE CITY OF ANTIOCH
CALLING FOR A MUNICIPAL ELECTION TO SUBMIT TO THE VOTERS
A LOCAL BALLOT MEASURE TO MAKE THE OFFICE OF
CITY TREASURER APPOINTED
AND REQUESTING THE BOARD OF SUPERVISORS OF CONTRA COSTA COUNTY
TO CONSOLIDATE A MUNICIPAL ELECTION ON A LOCAL MEASURE
WITH OTHER ELECTIONS TO BE HELD ON THE JUNE 5, 2012
REGULAR ELECTION DATE**

WHEREAS, a primary election is scheduled for June 5, 2012; and

WHEREAS, the City Council deems it advisable to submit to the voters a ballot measure to make the office of city treasurer appointed instead of elected because the traditional duties of this part-time office are increasingly handled by professional staff and consultants given the expertise required and the cost savings if not paying a salary stipend or benefits to the officer;

WHEREAS, the City Council is authorized to request an order that the ballot measure election be consolidated with other elections to be held on the same day and in the same territory (California Elections Code 10400 *et seq.*); and

WHEREAS, it is desirable that said ballot measure election be consolidated with the June 5, 2012 primary election; that within the City, the precincts, polling places, and election officers for the two elections be the same; that the Board of Supervisors canvass the returns of the City ballot measure election; and said City ballot measure election be held in all respects as if there were only one election;

NOW, THEREFORE, BE IT RESOLVED BY THE CITY COUNCIL OF THE CITY OF ANTIOCH:

1. Call for Election. The City Council hereby calls an election on Tuesday, June 5, 2012 for the purpose of submitting to the voters a ballot measure to make the office of city clerk appointed instead of elected. A majority vote is required for the passage of the ballot measure.

2. Form of Measure. The text of the proposed ordinance to be submitted to the voters is attached as Exhibit A to this resolution. The exact form of the measure to be voted upon shall appear on the ballot as follows:

CHANGING THE CITY TREASURER POSITION FROM ELECTED TO APPOINTED. Shall the office of city treasurer be appointed?	YES	
	NO	

The measure shall be designated on the ballot by a letter printed on the left margin of the square containing the description of the measure, as provided in California Election Code section 13116.

3. Transmission to the City Attorney. The City Clerk is directed, pursuant to Elections Code section 9280, to transmit a copy of the measure to the City Attorney for the purpose of preparing an impartial analysis of the measure to be submitted no later than 5:00 p.m. on Thursday, March 8, 2012.

4. Full Text of the Measure. The ballot measure question as set forth above is the full text of the measure.

5. Argument For the Measure. The City Council authorizes _____ to file the written primary argument in support of the ballot measure described above pursuant to Article 4 of Chapter 3 of Division 9 of the California Elections Code. Signatories to the argument shall be _____. Arguments for or against the measure shall be no longer than 300 words in length.

6. Date for Submission of Arguments. The City Clerk, with the concurrence of the County Elections Official, has fixed 5:00 p.m. Thursday, March 8, 2012 as the deadline for submittal of arguments for or against the measure.

7. Rebuttal Arguments. No rebuttal arguments shall be allowed.

8. Consolidation of Election. The City Council requests and consents that the Board of Supervisors of the County of Contra Costa, State of California order the consolidation of the election in the City of Antioch to be held on June 5, 2012, with any other election(s) to be held on the same regular election date, under California Election Code sections 10400 *et seq.*

9. Conduct of the Election. The consolidated election shall be held and conducted, election officers appointed, voting precincts designated, ballots printed, polls opened and closed, ballots counted and returned, returns canvassed, results declared, certificates of election issued, and all other proceedings incidental to and connected with the election shall be regulated and done by the County Clerk in accordance with the provisions of law regulating a regularly scheduled election. The Board of Supervisors is hereby requested to issue all officers of the

County charged with duties pertaining to the June 2012 election instructions to take any and all steps necessary for the holding of such consolidated election. (California Elections Code 10418.)

10. Costs. The City will reimburse the County for the actual cost incurred in conducting the election upon receipt of a bill stating the amount due as determined by the Election Official

11. Boundaries. The boundaries of the City have not changed since the November 2010 election.

12. Filing with County. The City Clerk is directed to file with the Board of Supervisors and the County Clerk of Contra Costa County certified copies of this resolution.

13. Filing the Notice. Pursuant to Elections Code section 9163 and 12111, the City Clerk's Office shall publish the required notice in a newspaper of general circulation in the City of Antioch.

* * * * *

I HEREBY CERTIFY that the foregoing resolution was passed and adopted by the City Council of the City of Antioch at a regular meeting thereof, held on the 28th day of February 2012, by the following vote:

AYES: Councilmembers

NOES:

ABSENT:

CITY CLERK , CITY OF ANTIOCH

CHANGING THE CITY TREASURER POSITION FROM ELECTED TO APPOINTED.
Shall the office of city treasurer be appointed?

**STAFF REPORT TO THE CITY COUNCIL FOR CONSIDERATION AT THE
COUNCIL MEETING OF FEBRUARY 28, 2012**

FROM: Lynn Tracy Nerland, City Attorney 

DATE: February 22, 2012

SUBJECT: Ballot Measure to Eliminate the Directly Elected Mayor

ACTION ITEM: Following the City Council's direction at its meeting on February 14, 2012, the following item is before the City Council for consideration, including the decision points outlined below under "Election Process":

1. Resolution calling a Special Municipal Election on June 5, 2012 for the submission to the voters of a local ballot measure to eliminate the position of a directly elected mayor and requesting that the Board of Supervisors of Contra Costa County to consolidate a municipal election on a local measure with other elections to be held on the June 5, 2012 Regular Election (Attachment A)

BACKGROUND:

Following public comment at the City Council meeting on February 14, 2012, the City Council asked that an item be put on the agenda for February 28, 2012 to adopt a resolution to submit a ballot measure to the voters at the June 5, 2012 election whether the current directly elected Mayor position should be eliminated. The February 28, 2012 Council meeting would be the last date that the Council could act on this issue to put it on the June 5, 2012 ballot.

Directly Elected Mayor

The mayor of a general law city, like Antioch, is typically selected by a vote of the members of the City Council. (Cal. Gov't Code section 36801) However, state law does allow the electorate to establish a system for direct election of the mayor by the voters. (Cal. Gov't Code section 34900 *et seq.*) This occurred by a ballot measure adopted in Antioch on April 11, 1972. The measure voted upon on was: "Shall electors elect a Mayor and four Councilmen?" Yes = 4,276 / No = 1,038. "Shall the term of Office of Mayor be: 2-years = 3,543 or 4-years = 1,601". Two years later on March 5, 1994, Antioch voters made it a four-year term for the directly elected Mayor.

A directly elected mayor in a general law city is different from the "strong mayor" form of government in some charter cities. A directly elected mayor in a general law city can receive additional salary if authorized by ordinance. However, the City's Municipal Code does not provide any additional salary to the Mayor, but the Council's adopted Travel and Expense policy does

02/28/12

provide a \$450 per month cap for travel expenses (\$100 more per month than a Council Member) and a \$100 per month cap for communications expenses (\$50 more per month a council Member).

Per state law, a directly elected mayor "with the approval of the city council, shall make all appointments to boards, commissions, and committees unless other specified by statute." (Cal. Gov't Code section 40605). Per practice, the Antioch Mayor also chairs the meetings of the City Council and the City Manager consults with him in preparing the agenda. The Mayor also sits as a Board Member on the Delta Diablo Sanitation District and is the City's representative at the County-wide Mayors' Conference.

According to statistics from the League of California Cities, as of July 1, 2011, there were 482 incorporated cities with 362 of those being general law cities and 120 being charter cities. As of May 2010, 149 cities had a directly elected mayor, which includes both general law and charter cities. Nearby cities with a directly elected mayor include Brentwood, Benicia, Dublin, Fairfield, Livermore, Martinez, Pleasanton, Richmond, San Ramon¹, Stockton and Tracy.

Elimination of the Directly Elected Mayor Position

In a general law city that has a directly elected mayor, the city council may submit a ballot measure to the voters on whether to eliminate the directly elected mayor position. (Cal Gov't Code section 34902). If a majority of the voters favor the elimination of the directly elected position, then the office is eliminated on the expiration of the incumbent's term. The city council would revert to a 5-member council and could adopt an ordinance specifying a process for the selection of a mayor.

The City's position of "Mayor Pro Tem" is the person who received the highest number of votes at the prior election and thus changes every two years, pursuant to the Antioch Municipal Code. Determining what process to follow to choose a mayor could wait until the outcome of the June ballot measure and staff has proposed no ordinance on that issue at this point.

Ballot Measure Language

State law mandates the form of the ballot measure question if asking whether to create a directly elected mayor position, but does not mandate the language for eliminating such a position. If the City Council wanted to put the issue to the voters, then proposed language would be:

Shall the position of a directly elected mayor be eliminated, so that the Antioch City Council is composed of five members who determine who will be mayor?

¹ For some reason, San Ramon does not show on the League's list of directly elected mayors, but the San Ramon City Attorney did confirm the fact.

Election Process

With a ballot measure placed before the voters, the City Council needs to make a number of decisions that would be memorialized in the adopted resolutions sent to the County Elections Department (Attachments A and B)

- **Argument in favor of the ballot measure: Will the City Council authorize the filing of the argument in support of the ballot measure? Is the Mayor, Mayor Pro Tem or other Council Member authorized to actually file the ballot measure?** If this is not done and there are multiple arguments submitted, then the California Elections Code has a hierarchy to allow the elections official to determine which argument is included in the voter information pamphlet for each position. Under state law, each argument cannot exceed 300 words in length. The deadline for the submittal of arguments for or against the measure is **5:00 p.m. Thursday, March 8, 2012.**

The City Council can also authorize the filing of an argument opposed to the ballot measure.

- **Signatories to the argument in favor of the ballot measure: Does the City Council want to submit the argument in support of the ballot measure as the 1) "Antioch City Council"; or 2) have each City Council Member sign the argument; 3) task the Mayor or a Council Member with obtaining appropriate signatories who may not all be City Council Members?** No more than 5 signatures can appear with the argument.

With the sales tax measure in 2011, the Mayor and Mayor Pro Tem were both authorized to file the written argument in support of the ballot measure and obtain the signatures to appear with the argument. It was determined that a representative group of individuals would sign the measure.

- **Rebuttal Arguments. Does the City Council want to prohibit rebuttal arguments?** This has been the practice in the past, in part due to the additional costs with the printing. In addition, timing issues with the County Elections Department occur with rebuttal arguments.

The resolutions also provide that the measure is to be transmitted to the City Attorney to prepare the Impartial Analysis pursuant to California Elections Code section 9280, which is also submitted to the voters with the ballot measure. The Impartial Analysis must be submitted no later than 5:00 p.m. on Thursday, March 8, 2012.

The City Clerk's Office will also be required to prepare and publish the consolidated "Notice of Election; Synopsis of the Measure and Notice to File Arguments."

FISCAL IMPACT:

The Contra Costa County Elections Division estimates the cost of a ballot measure at the June 5, 2012 election to be \$2.50 per registered voter with Antioch having approximately 42,000 registered voters. There would be an incremental cost for additional ballot measures, estimated by the County to be approximately \$0.25 per registered voter. Therefore, the cost of one ballot measure on the June 2012 election is approximately \$105,000 with the cost of two ballot measures approximately \$115,500. These costs are substantially less than holding a special election that is not consolidated with another statewide election.

The directly elected Mayor currently receives the same salary as the City Council Members, but \$100 per month higher cap for travel expenses and \$50 per month higher cap for communications expenses.

ATTACHMENTS:

- A. Resolution calling a Special Municipal Election on June 5, 2012 for the Submission to the Voters of a Local Ballot Measure to eliminate the position of a directly elected mayor and requesting that the Board of Supervisors of Contra Costa County to consolidate a municipal election on a local measure with other elections to be held on the June 5, 2012 Regular Election

RESOLUTION NO. 2012/

**RESOLUTION OF THE CITY COUNCIL OF THE CITY OF ANTIOCH
CALLING FOR A MUNICIPAL ELECTION TO SUBMIT TO THE VOTERS
A LOCAL BALLOT MEASURE TO ELIMINATE THE POSITION OF A
DIRECTLY ELECTED MAYOR
AND REQUESTING THE BOARD OF SUPERVISORS OF CONTRA COSTA COUNTY
TO CONSOLIDATE A MUNICIPAL ELECTION ON A LOCAL MEASURE
WITH OTHER ELECTIONS TO BE HELD ON THE JUNE 5, 2012
REGULAR ELECTION DATE**

WHEREAS, a primary election is scheduled for June 5, 2012; and

WHEREAS, the City Council deems it advisable to submit to the voters a ballot measure to make the eliminate the position of directly elected mayor and have the City Council composed of five members who will determine among themselves who will be mayor;

WHEREAS, the City Council is authorized to request an order that the ballot measure election be consolidated with other elections to be held on the same day and in the same territory (California Elections Code 10400 *et seq.*); and

WHEREAS, it is desirable that said ballot measure election be consolidated with the June 5, 2012 primary election; that within the City, the precincts, polling places, and election officers for the two elections be the same; that the Board of Supervisors canvass the returns of the City ballot measure election; and said City ballot measure election be held in all respects as if there were only one election;

NOW, THEREFORE, BE IT RESOLVED BY THE CITY COUNCIL OF THE CITY OF ANTIOCH:

1. Call for Election. The City Council hereby calls an election on Tuesday, June 5, 2012 for the purpose of submitting to the voters a ballot measure to eliminate the directly elected mayor position. A majority vote is required for the passage of the ballot measure.

2. Form of Measure. The text of the proposed ordinance to be submitted to the voters is attached as Exhibit A to this resolution. The exact form of the measure to be voted upon shall appear on the ballot as follows:

CHANGING THE MAYOR POSITION FROM ELECTED TO APPOINTED. Shall the position of a directly elected mayor be eliminated, so that the Antioch City Council is composed of five members who determine who will be the mayor?	YES	
	NO	

The measure shall be designated on the ballot by a letter printed on the left margin of the square containing the description of the measure, as provided in California Election Code section 13116.

3. Transmission to the City Attorney. The City Clerk is directed, pursuant to Elections Code section 9280, to transmit a copy of the measure to the City Attorney for the purpose of preparing an impartial analysis of the measure to be submitted no later than 5:00 p.m. on Thursday, March 8, 2012.

4. Full Text of the Measure. The ballot measure question as set forth above is the full text of the measure.

5. Argument For the Measure. The City Council authorizes [REDACTED] to file the written primary argument in support of the ballot measure described above pursuant to Article 4 of Chapter 3 of Division 9 of the California Elections Code. Signatories to the argument shall be [REDACTED]. Arguments for or against the measure shall be no longer than 300 words in length.

6. Date for Submission of Arguments. The City Clerk, with the concurrence of the County Elections Official, has fixed 5:00 p.m. Thursday, March 8, 2012 as the deadline for submittal of arguments for or against the measure.

7. Rebuttal Arguments. No rebuttal arguments shall be allowed.

8. Consolidation of Election. The City Council requests and consents that the Board of Supervisors of the County of Contra Costa, State of California order the consolidation of the election in the City of Antioch to be held on June 5, 2012, with any other election(s) to be held on the same regular election date, under California Election Code sections 10400 *et seq.*

9. Conduct of the Election. The consolidated election shall be held and conducted, election officers appointed, voting precincts designated, ballots printed, polls opened and closed, ballots counted and returned, returns canvassed, results declared, certificates of election issued, and all other proceedings incidental to and connected with the election shall be regulated and done by the County Clerk in accordance with the provisions of law regulating a regularly

scheduled election. The Board of Supervisors is hereby requested to issue all officers of the County charged with duties pertaining to the June 2012 election instructions to take any and all steps necessary for the holding of such consolidated election. (California Elections Code 10418.)

10. Costs. The City will reimburse the County for the actual cost incurred in conducting the election upon receipt of a bill stating the amount due as determined by the Election Official

11. Boundaries. The boundaries of the City have not changed since the November 2010 election.

12. Filing with County. The City Clerk is directed to file with the Board of Supervisors and the County Clerk of Contra Costa County certified copies of this resolution.

13. Filing the Notice. Pursuant to Elections Code section 9163 and 12111, the City Clerk's Office shall publish the required notice in a newspaper of general circulation in the City of Antioch.

* * * * *

I HEREBY CERTIFY that the foregoing resolution was passed and adopted by the City Council of the City of Antioch at a regular meeting thereof, held on the 28th day of February 2012, by the following vote:

AYES: Councilmembers

NOES:

ABSENT:

CITY CLERK , CITY OF ANTIOCH

Exhibit A

CHANGING THE MAYOR POSITION FROM ELECTED TO APPOINTED. Shall the position of a directly elected mayor be eliminated, so that the Antioch City Council is composed of five members who determine who will be the mayor?

**STAFF REPORT TO THE CITY COUNCIL
FOR CONSIDERATION AT THE MEETING OF FEBRUARY 28, 2012**

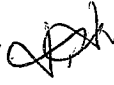
Prepared by: Brian Nunnally, Economic Development Analyst 
Approved by: Jim Jakel, City Manager 
Date: February 16, 2012
Subject: Commercial Code Enforcement/Shop Antioch Subcommittee
Abandoned Shopping Carts Letter

RECOMMENDATION

It is recommended that the Council approve dissemination of the draft letter, Attachment A, to businesses in Antioch that make shopping carts available to their customers.

BACKGROUND INFORMATION

In response to an Antioch Chamber of Commerce request to address the issue of abandoned shopping carts at the September 27, 2011 Council Meeting, the Council appointed Mayor Davis and Councilmember Agopian, along with two members of the Economic Development Commission and two Chamber representatives, to the Commercial Code Enforcement/Shop Antioch subcommittee. The attached draft letter is an action item borne out of the subcommittee meetings.

FINANCIAL IMPACT

None.

OPTIONS

- Approve dissemination of the letter
- Do not approve dissemination of the letter
- Provide other direction to Staff

ATTACHMENTS

A: Draft *Abandoned Shopping Carts Letter*



Date

Dear Business Name,

As both a cost savings measure for business name and an opportunity to reduce the perception of blight in the Antioch community that serves as your customer base, the City of Antioch is seeking your voluntary assistance with an effort to address the number of abandoned shopping carts that are being left around the city. While this issue is certainly not unique to business name, nor to the City of Antioch, what is unique is the City of Antioch's effort at engaging businesses on a voluntary basis to help address this problem before it grows any worse.

Specifically, the request is that any business that makes shopping carts available to its customers commit to a 48-hour pickup of any shopping carts it owns that have been abandoned outside of its parking lot. The City of Antioch believes this makes business sense and enhances the appearance of our community.

The City of Antioch, and most importantly, the citizens of Antioch thank you in advance for your cooperation and vigilance in this matter.

Should you have any questions, please do not hesitate to contact me at bnunnally@ci.antioch.ca.us or by phone at (925) 779-6168.

Thank you,

Brian Nunnally

Economic Development

City of Antioch

CITY OF ANTIOCH AS SUCCESSOR AGENCY TO
THE ANTIOCH DEVELOPMENT AGENCY
CLAIMS BY FUND REPORT
FOR THE PERIOD OF
JANUARY 19 - FEBRUARY 22, 2012
FUND/CHECK#

331 Antioch Development Agency			
131922	PERS	PAYROLL DEDUCTIONS	568.99
131971	CONTRA COSTA ECONOMIC PARTNERSHIP	FY11/12 MEMBERSHIP	5,000.00

CITY OF ANTIOCH AS HOUSING SUCCESSOR TO
THE ANTIOCH DEVELOPMENT AGENCY
CLAIMS BY FUND REPORT
FOR THE PERIOD OF
JANUARY 19 - FEBRUARY 22, 2012
FUND/CHECK#

227 Antioch Development Agency
131993 KENNEDY, JANET

CONSULTANT SERVICES 2,850.00